

QC
Avro
CF105
72-Sys.
11-27

JUNE 1957

UNCLASSIFIED SECRET

**ARROW 2
ELECTRICAL SYSTEM**

REPORT No. 72/SYSTEMS 11/27

ENGINEERING DIVISION



AVRO AIRCRAFT LIMITED

FILE IN VAULT

NRC - CISTI
J. H. PARKIN
BRANCH

MAY 11 1995

ANNEXE
J. H. PARKIN
CNRC - ICIST

UNCLASSIFIED

SECURITY WARNING

This document is classified "SECRET" and is intended solely for the use of the recipient and such persons as have been delegated to use it in the course of their duty and may only be used in connection with work performed for or on behalf of Her Majesty's Canadian Government.

The unauthorized retention or destruction of this document or disclosure of its contents to any unauthorized person is forbidden.

Failure to comply with any of the above instructions is an infraction of the Official Secrets Act.

Any unauthorized person obtaining possession of this document, by finding or otherwise, must forward it, together with his name and address, in a registered envelope, to the Engineering Division, AVRO Aircraft Ltd., Malton, Ontario, Canada.

Classification cancelled/changed to.....

by authority of.....(date).....

Signature *J. M. Hutchings* Rank *S/P*

This is copy number79.....

Issued to

Date

UNCLASSIFIED

SECRET
UNCLASSIFIED

ARROW 2 ELECTRICAL SYSTEM

REPORT NO. 72/SYSTEMS 11/27

JUNE 1957

This brochure is intended to provide an accurate description of the system(s) or service(s) for purposes of the Arrow 2 Mock-up Conference, and is not to be considered binding with respect to changes which may occur subsequent to the date of publication.

COMPILED BY

W. Brown

APPROVED BY

Alan R. Bulley

ENGINEERING DIVISION

AVRO AIRCRAFT LIMITED

MALTON — ONTARIO

TABLE OF CONTENTS

CHAPTER	PARA	SUBJECT	PAGE
1.		Introduction	1
2.		Design Objectives	4
3.		General Description of System	6
4.		Index of Services	8
	4.1	Power System	9
	4.2	Starting & Ignition	13
	4.3	Engine Services	16
	4.4	Landing Gear System	20
	4.5	Fuel Control	23
	4.6	Fuel Capacitance Indication	31
	4.7	Fire Protection System	32
	4.8	Canopy Actuation	34
	4.9	Missile Hydraulics - Control System	36
	4.10	Air Conditioning System	40
	4.11	Flight Services & Master Warning	42
	4.12	Cockpit Lighting	47
	4.13	External Lights	48
	4.14	Duct De-Icing	49
	4.15	Radome De-Icing Windscreen & Canopy Anti-Icing	53
5.		Description of Equipment	57
	5.1	A. C. Generator, Controls & Transformer Rectifier	57
Appendix 1		Parts to Avrocan Specifications	58
Appendix 2		A Review of the Engineering Decisions on Battery Selection for the Arrow 2	59

LIST OF ILLUSTRATIONS

		PAGE
Figure 1	Wiring Diagram - Power System	70
Figure 2	Wiring Diagram - Starting & Ignition	71
Figure 3	Wiring Diagram - Engine Services	72
Figure 4	Wiring Diagram - Landing Gear System	73
Figure 5	Wiring Diagram - Fuel Control	74
Figure 6	Wiring Diagram - Fuel Capacitance Indication	75
Figure 7	Wiring Diagram - Fire Protection System	76
Figure 8	Wiring Diagram - Canopy Actuation	77
Figure 9	Wiring Diagram - Control System - Missile Hydraulics	78
Figure 10	Wiring Diagram - Air Conditioning	79
Figure 11	Wiring Diagram - Flight Services & Master Warning	80
Figure 12	Wiring Diagram - Cockpit Lights	81
Figure 13	Wiring Diagram - Exterior Lights	82
Figure 14	Wiring Diagram - Intake Ramp De-Icing	83
Figure 15	Wiring Diagram - Radome, Windscreen & Canopy De-Icing	84
Figure 16	Wiring Diagram - Duct De-Icing	85



1. Introduction

- 1.1 An A.C. power generating system, utilizing static transformer rectifiers for the D.C. requirements, has been selected for the ARROW 2.

Due to the extreme environmental conditions to be encountered by the Arrow 2 aircraft, oil cooled brushless generators with oil lubricated bearings will supply the A.C.

A twin generator installation, one being mounted on each engine, is required in order to provide a system with reliability compatible with that of a twin engined aircraft. Because of the frequency sensitive nature of the electronic loads to be supplied by the electrical system, the generators are driven by mechanical-hydraulic constant speed units. This choice of drive, over that of an air turbine, was made in view of the high overall operating efficiencies to be gained, plus the saving in weight and space.

In line with this design approach, equipment and circuitry, between the generators and the electrical power utilizers, have been laid out to provide the same degree of reliability. In addition, the aircraft system has been divided into two separate and self-contained systems, one on each generator, to ensure maximum availability of power in the event of the



failure of one generator. Circuitry simplification is also achieved.

The high performance of the aircraft places additional demands upon the crew, and dictates a design which will achieve, to the greatest extent, a completely automatic system. The system is, therefore, designed so that in case of failure in one system, the essential loads are automatically transferred to the operating side, in order to ensure continuity of supply. This action will be indicated to the pilot so that he may change the flight plan, and/or report the defect to the maintenance crew. Consistent with this approach, all circuit breakers (with the exception of the damping system circuit breakers) are located outside of the cockpit where they are readily accessible for ground inspection.

The electrical circuits have been laid out to achieve, as far as possible, invulnerability to all anticipated types of aircraft damage, consistent with the requirement of minimum overall weight.

1.2 The system is designed to meet the following operational requirements:

1.2.1 Altitude

Sea level to 60,000 feet.

UNCLASSIFIED
AVRO ARROW

1.2.2 Temperature

1.2.2.1 Components located in areas which are not supplied with cooling air are designed for operation throughout the range -65°F to $+248^{\circ}\text{F}$, the latter temperature being the result of the aero-dynamic kinetic heating effects at $M = 2.0$. (For flight limitations at this temperature see paragraph on "Flight Limitations").

1.2.2.2 Units located in areas supplied with cooling air will not be subjected to temperatures in excess of $+160^{\circ}\text{F}$, thus permitting the use of equipment already proved and qualified throughout the -65°F to $+160^{\circ}\text{F}$ range.

1.2.3 Flight Attitudes

All operational attitudes including inverted flight, with limitations as shown in paragraph 1.2.3.

1.2.4 Flight Limitations

1.2.4.1 Inverted flight duration of 15 seconds.

1.2.4.2 Endurance at maximum speed: 10 minutes at $M = 2$, based on 15 minutes cruise out at $M = 1.5$ and fuel temperature limitations at the engine inlet of 160°F .



2. Design Objectives:

- 2.1 To provide power for the aircraft electrical services.
- 2.2 To provide power for the aircraft electronic services when necessary.
- 2.3 To provide power, as required for the weapons, prior to launch.
- 2.4 To provide power for the aircraft anti-icing and de-icing services.
- 2.5 To provide 100% reserve power generation capacity, over the known requirements of the electrical services to date, and to allow for growth with future aircraft development.
- 2.6 To provide adequate power to permit safe flight in the event of failure of any one generating system.
- 2.7 To meet the above requirements with a system having a minimum installed weight.
- 2.8 To provide a system which will power all essential services, during a twin-engine flame out, for a period long enough to permit the relighting procedure to be carried out.
- 2.9 To meet the design requirements of ARDCM-80-1 and CAP-479, which includes the following specifications:
 - MIL-E-7080 Electrical Equipment: Installation of Aircraft General
 - MIL-E-7563 Electrical Equipment: Aircraft - Installation of General Specification for

UNCLASSIFIED



MIL-E-7614 Electrical - Alternating Current Aircraft Installation of General Specification for

MIL-E-7894 Electric Power, Aircraft, Characteristics of

2.10 To meet the general design requirements of Specification AIR-7-4 and, in particular, those of para. 9 "Electrical Equipment".



3. General Description of System

3.1 The CF-105 airplane is equipped with two completely independent and self-contained electrical systems, one being powered by each aircraft engine. This primary mechanical power is converted by the generators into 120/208 Volt, three phase, 400 C.P.S. electrical power. A portion of the generated A.C. is rectified to supply the aircraft D.C. loads at 27.5 Volts D.C. The generation, rectification and control equipment for each system is identical and symmetrical up to the main A.C. and D.C. buses. The distribution of A.C. power within the aircraft is arranged into two separate systems, with provision for automatic switching of essential loads to the operating system, in the event of failure of one system. D.C. distribution is carried out from a common D.C. bus supplied concurrently by both systems.

The load centres for each electrical system of the aircraft are located as follows:

Station 129-147 E-1 Forward Circuit Breaker Panel housing

the following:

Forward Main D.C. Bus

Shedding D.C. Bus

Emergency D.C. Bus

Battery Bus

Forward Primary A.C. Bus

Forward Emergency A.C. Bus



Station 490 E-20 Aft Circuit Limiter Panel:

Main D.C. Bus

De-icing D.C. Bus

Primary A.C. Buses

E-21 Refuelling & Test Panel

Emergency D.C. Bus

Station aft of 485

E-47 Emergency A.C. Limiters

Station aft of 176

E-40 W/S and Canopy High Voltage Limiters.

4. Index of Services

Paragraph	Service	Schematic Drawing
4.1	Power System	Fig. 1
4.2	Starting & Ignition	Fig. 2
4.3	Engine Services	Fig. 3
4.4	Landing Gear Actuation & Indication	Fig. 4
4.5	Fuel Control	Fig. 5
4.6	Fuel Capacitance Indication	Fig. 6
4.7	Fire Protection System	Fig. 7
4.8	Canopy Actuation	Fig. 8
4.9	Control System-Missile Hydraulics	Fig. 9
4.10	Air Conditioning System	Fig. 10
4.11	Flight Services & Master Warning	Fig. 11
4.12	Cockpit Lights	Fig. 12
4.13	External Lights	Fig. 13
4.14	Duct De-Icing	Fig. 14
4.15	Radome Windscreen & Canopy De-Icing	Fig. 15



4.1 Power System

4.1.1 General

The electrical power supply is provided by two engine mounted, oil cooled, 40 K. V. A., 3 phase, 120/208 volts, 400 C. P. S., A. C. generators. Each generator is driven independently by its respective aircraft engine, through a mechanical-hydraulic constant speed drive unit, which is capable of maintaining the frequency output constant, within $\pm 1\%$ for steady state conditions and $\pm 5\%$ under transient conditions.

The D. C. is provided by two, static, 4.5 KW, transformer rectifier units, each of which is supplied independently from its respective 40 K. V. A. generator. Cooling air to the T. R. units is supplied from the aircraft air conditioning system.

4.1.2 A. C. System

The A. C. loads are divided into two groups, and each group is supplied by one K. V. A. generator through its Primary A. C. buses, thus forming two completely independent and self-contained electrical systems, which are designated:- the left hand system and the right hand system.

The left hand primary A. C. buses supply the power for "Electronic Services", and the normal power for "Emergency A. C." loads.

UNCLASSIFIED

AVRO ARROW



The right hand primary A.C. buses supply the power for the "Electrical Services".

When the engine is up to speed, and the generator has not been "Tripped", the power will be fed through the line relay to the primary A.C. bus. If the system has been tripped, the generator switch must be momentarily selected to "Reset", and the generator will be put back on to the line. Should the generator have been tripped by a fault; on selection of reset and should the fault still remain, the generator will come on the line once and then trip out, but will not cycle. In the event of a generator failure, or should the engine shut down, the corresponding "Line Relay", will be energized to "TRIP", transferring the applicable primary A.C. loads to the operating generator and removing the D.C. shedding loads. If the pilots "Missiles-De-Ice" selector switch is in the normal (missiles) position, the de-icing D.C. loads will also be removed. At the pilots discretion, he may switch to "De-Icing", removing both A.C. and D.C. armament supply and making de-icing supply once more available. Should full power be returned to the aircraft, all loads will be automatically reconnected. During a double engine flame out, a solenoid-operated, hydraulic valve will be energized to drive an emergency A.C. generator. This generator will supply power for the emergency A.C. loads.

Should the left or right hand generator shut down due to a bus fault, the A.C. loads on that particular bus will not be transferred to the operating generator, since a bus fault would shut down the remaining generator if transferred.

In the event of a bus fault removing the left/generator from the system, the emergency A.C. generator will automatically take care of the emergency A.C. loads.

4.1.3 D.C. System

The transformer rectifier units are fed from their respective primary A.C. buses, and the output from each is fed to the Main D.C. bus. The main D.C. bus supplies essential power through tributary buses, including the battery and emergency buses, and also the D.C. shedding bus to which all unessential loads are connected.

The D.C. shedding bus is connected to the main D.C. bus through one set of contacts of a D.P.S.T. relay. Should there be a failure in either side of the system, this relay will be de-energized and the D.C. shedding loads removed. However, when the aircraft is on the ground with only one engine running and the ground supply unit connected to the aircraft, the D.C. shedding relay and the D.C. shedding bus will be energized.



The emergency D.C. bus is connected to the battery bus through the contacts of the emergency bus relay. This relay is energized when the aircraft master electrical switch is selected to the "ON" position.

The battery bus is connected to the forward main D.C. bus through the contacts of a reverse current relay. In the event of the failure of both transformer rectifier units, or a line fault which would result in the battery feeding a reverse current to the forward main D.C. bus, the reverse current relay would open, isolating the battery and emergency D.C. buses and supply an indication to the pilot that the battery was being used.

If a fault should cause one of the transformer rectifier units to be removed from the system, provision is made for the pilot to attempt a "RESET". The T.R.U. will be returned to the system provided the fault has cleared.

4.1.4 External Supply System

External A.C. power is provided by an "A.C., Multi-Purpose, Ground Servicing Unit".

When the unit is connected to the aircraft and operating correctly, the aircraft master electrical switch may be selected to the "ON" position. This action actuates the external power control relay, which feeds signals to trip the left and



right hand ground power relays, supplying power to the primary A.C. buses and transformer rectifier units. All buses are now energized, but the aircraft "A.C. failure" warning lights are "on".

When the aircraft engines are started and attain proper speed, the corresponding line relay is closed, removing the "trip" signal to the ground power relay and supplying a signal to "close" the ground power relay. This effects the removal of the external A.C. power which is replaced by the aircraft power. The aircraft A.C. failure warning light goes out, assuring the pilot of the functioning of the aircraft system, prior to taxi.

4.2 Starting & Ignition

4.2.1 The starting and relight system comprises:

- (a) The system within the airframe, with its associated switching, starter controls, relays, fuel solenoids and igniters.
- (b) The "Pneumatic Starting Unit"; which is a ground unit supplying compressed air through two lines to the aircraft turbine starters and also supplying 28 V. D.C. and 115 V. A.C. 400 cycles to the aircraft for starting control, intercommunication and fuel metering. The air lines and electrical cable are connected to the aircraft by means of

UNCLASSIFIED
AVRO ARROW

special lanyard release connectors. These connectors are automatically withdrawn from the aircraft when it taxis away from the starting location.

- 4.2.2 The following procedure is adopted prior to engine starting:
- (a) The air supply lines are connected to the aircraft.
 - (b) The ground supply electrical cable is connected to the aircraft.
 - (c) The pneumatic starting unit is started and when indications are satisfactory, the electrical power is applied to the aircraft.
 - (d) The aircraft master electrical switch is selected to "ON".

The conditions then existing in the aircraft are as follows:

- (a) The starting power relay is energized, removing the aircraft battery from the battery bus.
- (b) The emergency bus relay is energized, and the emergency bus is connected to the battery bus.
- (c) The ground control relay and the engine supply starting relays are energized, supplying 27.5 V. D.C. and 115 V. A.C. to the left and right fuel metering amplifiers.

The engines may now be started singly or simultaneously.

4.2.3 Starting

- (a) The engine "Power Control Lever" is selected to the required starting position.
- (b) A starting switch is selected momentarily to the "Start"

UNCLASSIFIED

position. The starting relay energizes and locks-in supplying power to the aircraft starting system, energizing "open" the appropriate air solenoid on the ground starting unit.

When the engine attains a speed of approximately 200 r.p.m. the centrifugal switch S1, in the aircraft starter unit, closes and the "Ignition Relay" pulls in; energizing the "Starting Fuel Pump Solenoid", the "Torch Igniter Fuel Solenoid", and the "Igniters". The check valve switch closes under fuel pressure from the supplementary starting fuel pump. When the engine speed reaches approximately 1500 r.p.m., both centrifugal switches S1 and S2 in the aircraft starting unit open. The ignition and starting relays drop out, and the torch igniter fuel solenoid and the igniters are de-energized. When the main engine fuel pump has built up the necessary pressure to open the check valve switch, which de-energizes the starting fuel pump solenoid, the supplementary starting fuel pump is shut down. The system is thus returned to normal.

Should it become necessary to interrupt the above starting cycle, the power control lever is returned to the "OFF" position. This action opens a limit switch causing the "starting relay" to be de-energized and the system to return to normal. A further "START" may then be attempted.

4.2.4 Relight

To relight the engine after flame out and while the aircraft is airborne, the "Relight Switch", on the power control lever, is operated and held. The aircraft starting unit is by-passed and the ignition relay is energized directly. The starting fuel pump, the torch igniter fuel solenoid and the igniters are energized as before plus a "Torch Igniter Oxygen Solenoid". This latter functions to introduce a determined quantity of oxygen adjacent to the torch igniter, in order to improve the altitude relight characteristics.

4.2.5 Motoring

To "Motor" the engine without operating the ignition system, the power control lever is selected to the "OFF" position, and the starting switch selected to "Motor" and held for a prescribed time. This energizes directly, the air valve on the ground starting unit. To supply a fuel flow through the engine during the "Motoring" period, the power control lever is advanced from the "OFF" position.

4.3 Engine Services

4.3.1 Jet Pipe Temperature Indication

A thermocouple system is provided, using four thermocouples located on the shroud ring of each engine. Two indicators, one for each engine, are incorporated in the performance indicator located in the pilot's cockpit.



4.3.2 Oil Pressure Warning

When the oil pressure falls to between 30 and 20 p. s. i., a pressure switch is actuated, and an amber warning light in the pilot's cockpit is illuminated.

4.3.3 Fuel Pressure Warning

When the fuel pressure falls below 18 p. s. i. absolute, a pressure switch is actuated, and an amber warning light in the pilot's cockpit is illuminated.

4.3.4 Variable Stator Control

This system controls the angle of the first row of blades in the engine, and consists of an engine speed switch and an actuating solenoid. When the engine attains a certain speed the blades are positioned to the high speed configuration, and when the engine speed falls below that r. p. m. the blades are returned to the low speed configuration.

4.3.5 Emergency Fuel Control & Indication

In the event of the malfunctioning of any section of the automatic fuel flow system, the pilot can switch to "Emergency Fuel". This selection actuates the emergency fuel control valves and gives the pilot manual control of the fuel flow to the engines. When emergency fuel is selected, an amber light, located in the pilot's cockpit, will go "ON".

4.3.6 Low Rotor Overspeed Indication

Under certain flight conditions, the engine low pressure

compressor may tend to overspeed.

In the event of this occurring, an internal governor actuates a limit switch which supplies power to the corresponding amber "Low Rotor Overspeed", warning light in the pilot's cockpit.

This light should remain on for a very minimum period, which time will be specified in the engine manufacturers operating instructions. This is the time required for the low pressure governing system to modulate the fuel flow to the low pressure rotor.

Should the warning light remain on beyond the specified limit, the pilot will then take the necessary corrective action.

4.3.7 Engine Anti-Icing

This system utilizes hot air bleed from the engine compressor 10th stage delivery, for surface heating.

The temperature of the bullet is sensed by two temperature sensitive resistance elements attached to the inside skin of the nose fairing. The signals from these sensors are relayed by a control system which operates a motorized butterfly valve, modulating the flow of hot air as the skin surface temperature changes.



The system commences to operate on receipt of the first icing signal from either of the two ice detectors situated on the lip of each air intake.

4.3.8 Thrust Ratio Indication

This system is required in order that the pilot may be acquainted with the percentage of thrust under any flight condition.

Details of this system have not been finalized at this time.

4.3.9 After-Burner Ignition:

The "Hot Steak" ignition system is used to ignite the afterburner system. As the power control lever is advanced into the afterburner range, a solenoid shut off valve is energized open by a limit switch in the power lever switchgear. At the same time a hot streak igniter valve is energized open to introduce a metered pulse of fuel into the gas flow upstream of the engine turbine section. This pulse of fuel ignites and produces a long streak of flame through the turbine into the region of the afterburner fuel nozzles. The scheduled fuel flow passing simultaneously through the nozzles is thus ignited.

As soon as afterburner light up is achieved, the hot streak igniter system automatically shuts off. A modulated

UNCLASSIFIED
AVRO ARROW 

afterburner function is maintained until such time as the power lever is retracted below the afterburner range.

4.4 Landing Gear System

This system is comprised of landing gear actuation, landing gear position indication, nose wheel steering and automatic wheel braking to prevent wheel spin while the landing gear is being retracted.

4.4.1 Landing Gear Actuation

4.4.1.1 Normal Operation

Normal landing gear extension and retraction is controlled by a special three pole, double throw switch with no "OFF" position. A solenoid actuated locking device prevents the selection to "UP", while the aircraft is on the ground.

The power to actuate the solenoid which releases the locking mechanism is supplied through limit switches, actuated by the main undercarriage scissors, when the aircraft is airborne.

Actuation of the complete landing gear is controlled by one electrically operated hydraulic valve. The solenoids of the hydraulic valve are energized by the selection of the landing gear lever to either "UP" or "DOWN".

4.4.1.2 Emergency Operation

"Emergency Down" selection is accomplished by pulling the landing gear actuation lever down through a gate and actuating



a pneumatic valve mechanically. There is no provision for "Emergency Up".

4.4.2 Landing Gear Indication

An electrically operated indication system in the pilot's cockpit shows the positions of all landing gear units by means of individual red and green lights. The lights are operated by limit switches incorporated in the door up-locks and the jack and telescopic-stay down-locks.

When the complete landing gear is down and locked and the power on, three green lights will be "ON".

When an "UP" selection is made, the "down" limit switches reverse their contacts immediately the down-locks are broken, and the green lights go "OFF". Supply, through the down lock switches and the door up-lock limit switches, in the unlocked position, illuminates three "RED" lights, indicating that the landing gear is neither locked up nor down. When the landing gear is up and the doors locked, the door-locked limit switches are actuated, and the circuits to the red lights are opened. In this condition all indicator lights are "OFF".

Since the limit switches on each landing gear unit are connected to separate lights in the indicator, the position of each undercarriage is individually indicated. Therefore if one or more of the landing gear units are not locked up or down, the indicating



light for that particular unit will show "RED".

In the event of failure of one or more green lights, three new lamps may be selected by actuating a switch incorporated in the main "position indicator".

A red light is incorporated in the handle of the landing gear selection lever, and the circuitry to this light is designed to serve two purposes.

- (a) The light will go "ON" when any landing gear unit is neither locked down nor up. This is supplementary to the main indicator and is designed as a safety measure.
- (b) The light will flash "OFF" and "ON" while the aircraft is in flight below 10,000 feet if the pilot retards the power control levers, preparatory to land, with undercarriage retracted.

An aneroid switch wired in series with the light, prevents the flashing signal above 10,000 feet with a power control lever retarded.

The master test switch, located in the cockpit, will test the red position indicator lights when actuated.

4.4.3 Nose Wheel Steering

The nose wheel steering system is selected by actuating a push button switch on the control column, which energizes the solenoid of the nose wheel steering hydraulic valve thus



permitting flow of hydraulic fluid to the steering jack.

The push button switch is wired in series with the nose wheel scissors limit switch, permitting operation of the hydraulic valve solenoid only when the aircraft is on the ground.

4.4.4 Wheel Braking

A solenoid in each main wheel brake control valve is automatically energized when the landing gear up selection is made. The valve admits hydraulic pressure to the wheel brakes to stop wheel spin during the period of retraction.

When the landing gear is up and the doors locked the solenoids are de-energized.

4.5 Aircraft Fuel Control

4.5.1 The fuel system consists of two almost symmetrical sub-systems; the port sub-system consisting of the aft fuselage tank together with the six wing tanks normally feeding the port engine, and the starboard sub-system consisting of the forward fuselage tank together with the six wing tanks normally feeding the starboard engine.

Fuel is supplied from each system to its respective engine by an engine driven booster pump located in the collector tank of its sub-system. Each tributary tank is drained through its fuel-no-air valve, into its respective collector tank, according to a predetermined sequencing when the



master sequence switch is selected to either "maximum shift" or "minimum shift".

With the pilots low pressure cock switches and fuel cross-feed switches selected to "normal", and the master sequence switch selected to the flight plan sequence, the system under normal flight conditions is virtually automatic.

The foregoing system comprises the following equipment and its more detailed function:

4.5.1.1 Fuel Distribution Control System

(a) Fuel No-Air Valves:

These valves are de-energized "open" when the tank in which they are installed is draining into its collector tank. They remain de-energized when draining is completed. The fuel-no-air valves in the first left and right tank selected by the master sequence switch are de-energized "open", and the level sensor in the tank, on sensing a tank empty condition, actuates a relay in the sequence control unit to de-energize the next fuel-no-air valve in the sequence.

(b) Level Sensors:

One level sensor is installed in each tank, and its function is described in (a). However, the sensor in each collector tank has a different function. It is installed in parallel to, and is supplementary to, the C.G. capacitance units; and

in the event of a failure in the normal monitoring system, it will supply a signal to illuminate a fuel low level warning light when its respective collector tank capacity drops to 60% and at the same time the 90% signal described in para C, will be paralleled.

(c) Collector Tank Monitor:

This system is comprised of capacitance units; 7 in each collector tank and a liquid level control unit. The capacitance units are so mounted that they will indicate, within 3%, the 70% and 90% fuel levels.

Should a collector tank fuel level drop to 90% the system will monitor a signal to the sequence control unit, energizing a relay which de-energizes the next fuel-no-air valve in the sequence, causing two tanks to drain instead of one. Should the collector tank drop to 70% the relay energized in the sequence control unit will cause three tanks to drain instead of one or two. At this point the pilots "Low Level Fuel" warning light goes 'ON'.

When the collector tank level returns to normal, the additional tank valves will be energized closed, and the original tank (if not empty by this time) will continue to drain into the collector tank. The low level warning light will go 'OFF'.



4.5.1.2 Fuel Valve Control

The left and right low pressure cocks are controlled by two, two pole double throw switches with designated positions "NORMAL" and "OFF".

When a switch is selected to normal, power is supplied from the emergency D.C. bus to open the fuel valves.

When the switch is selected to "OFF", power is supplied from the battery bus to close the valves.

When either the open or close valve travel is completed, internal limit switches open removing the power from the valve.

4.5.1.3 Cross Feed System

The cross feed system operates on selection of the cross feed switch in the pilots' cockpit. If left cross feed is selected, the cross feed valve is energized "open" and the right system isolating valve energized "closed", (left system isolating valve energized "open") thus allowing fuel supply from the left hand sub system only. Similarly, if right cross feed is selected, the cross feed valve is energized "open" and the left hand isolating valve energized "closed", (right hand isolating valve energized "open"), thus allowing fuel supply from the right hand sub system.



Internal limit switches remove power from the valves on completion of valve travel to either open or close position.

4.5.2 Ground Refueling System

- 4.5.2.1 The system is composed of the refueling and control switches, tank level sensing valves, air pressure relief override valves, collector tank override valves and tank indicator lights, all of which are located on the aircraft.

With the refueling adaptor doors open, the "Fuel Transfer Off" warning indicator light will go "ON". This light warns the pilot that the system is not in flight condition.

When the refueling master switch is selected to "ON", D.C. power will cause the fourteen indicator lights to go "ON" and energize open the air pressure relief override valves and de-energize "closed" the collector tank override valves. A signal will also be impressed on the "Fuel Transfer Off" indicator light in parallel with the signal from the refueling adaptor door being open.

If the flight plan calls for the complete filling of the aircraft system, the refueling selector switch is selected to "FULL".

The right and left refueling control switches are then selected to "ON", which energize open the fourteen tank level sensing valves. The system is now ready for a "PRE-CHECK".



4.5.2.2 Pre-Check Test

When the fuel begins to flow into the aircraft system, the pressure opens the shut off valve in each tank, and as it does so, the corresponding refueling indicator light goes "OFF". After a short predetermined time the right and left refueling control switches are selected to "OFF", and the tank level sensing valves are de-energized closed. When the incoming fuel has filled the tank reservoirs, the reservoir float rises closing the float valve, which in turn puts a back pressure on the tank shut off valve, causing it to close against incoming fuel pressure.

As each tank shut off valve closes, the corresponding refueling indicator light goes "ON" again.

This completes the pre-check test and indicates that refueling of the aircraft may proceed.

To continue the "FULL" refueling, the left and right refueling control switches are once again selected to "ON".

The indicator lights remain on momentarily until the reservoirs are dumped into the tank by the re-opening of the tank level sensing valves. The float valves are also opened relieving the back pressure on the tank shut off valves which open, actuating the limit switch and removing the power from the indicator lights.



When the tanks are filled, the reservoir float valves are closed as in the pre-check, the tank shut off valves close and the fourteen indicator lights go "ON".

The refueling control switches are selected to "OFF"; the refueling hoses are disconnected from the aircraft, the adaptor doors are closed, and when the refueling master switch is selected to "OFF", the fourteen fuel indicator lights, and the "Fuel Transfer Off" indicator light will go "OFF". The aircraft fuel system is now in flight condition.

4.5.2.3 Partial Refueling: No. 1 and No. 2

When the flight plan calls for partial refueling, only certain tanks are selected to receive fuel. When the refueling selector switch is selected to either "Partial No. 1, or Partial No. 2," and the refueling master switch and the right and left refueling control switches are selected to "ON", those tank level sensing valves are energized open according to the predetermined partial refueling pattern allowing fuel flow into their respective tanks.

Indicator lights for the tanks not selected will remain "ON" during these partial refueling patterns, while the indicator lights on the tanks selected for refueling will sequence as for full refueling.

Prior to partial refueling, a pre-check of the system must be made.



4.5.3 De-Fueling

De-fueling is a normal fuel transfer with an exterior pressure source.

The master refueling switch is left in the "Off and Defuel" position.

When the tributary tanks are emptied by the external pressure supply, the non pressurized collector tanks are emptied by suction from the refueling truck.

4.5.4 External Tank:

To meet the requirements of a long ferry mission a single external tank is installed on the under side of the fuselage.

Fuel transfer is effected by air pressure from the aircraft pressurization system through an electrically operated air pressure valve. The external tank is the first tank to drain and empty in either the maximum or minimum shift sequence, and is connected to the next internal tanks, in the sequence, through the sequence control unit and the fuel no-air valves.

When the external tank low level sensor senses the tank is empty, it supplies a signal to the sequence control unit, and the fuel no-air valve (of the next tank in the sequence on either side) is energized open. If however, the fuel flow from the external tank is not great enough to satisfy the demand of the

UNCLASSIFIED



engines, the fuel no-air valves, in the next tank sequence, will be opened long enough to allow their tanks to drain into their respective collector tanks and bring the contents up above the 90% level.

When the external tank is empty the air pressure valve is de-energized closed, and the "Tank Empty/Jett. Fail" light will indicate in the cockpit. The fueling of the external tank is done manually and the level checked visually.

Jettisoning of the external tank may be accomplished as follows:

- (a) actuation of the pilots' external "Tank Jettison" switch.
- (b) actuation of the pilots' "Stores Jettison" switch.
- (c) by a signal from the electronics system, should the pilot have failed to jettison the tank prior to missile launching.

Should the electrical jettison fail, the cockpit light will still give a warning to the pilot until he operates the mechanical jettison release.

4.6 Fuel Contents Indication (Ref. Fig. 6)

The fuel quantity indicating system comprises two independent and symmetrical systems of the capacitor type, one right hand and one left hand, and each indicating the total weight of fuel remaining in the tanks for their respective sides.



The right indicator shows the total contents of the seven tanks 1, 3R, 4R, 5R, 6R, 7R & 8R, and the left indicator shows the total contents of the seven tanks 2, 3L, 4L, 5L, 6L, 7L & 8L.

Each tank contains a number of capacitor units wired in parallel, and they in turn are wired in parallel with all the other units in the same system. The number of units in each tank is sufficient to ensure accurate indication over a wide range of flight attitudes. Collector tanks 5L & 5R each contain a compensator unit, which is connected to its respective amplifier/indicator unit, to compensate for changes in dielectric properties and densities of the fuel.

4.7 Fire Protection System (Ref. Fig. 7)

This system consists of a fire detection system and a fire extinguisher system, which provides protection for each engine and the hydraulic equipment bay.

4.7.1 Fire Detector System

The system consists of a detector cable, warning light and control unit, and it functions as described below.

The insulation resistance of the detector cable falls on exposure to localized heating, and this characteristic is utilized to light a warning lamp in the pilots' cockpit when the resistance drops to a preset value. The value of insulation resistance which causes the light to glow is set by a resistor



connected across terminals 1 & 4 of the control unit. This also permits interchangeability of the control unit between systems having detector cables of different lengths by merely changing the resistors. For test purposes a switch (located on the refuelling & test panel E21) is provided which opens the continuous loop of the detector cable and grounds one end when actuated, thus causing a warning signal. The fire detector system is supplied from the emergency bus.

4.7.2 Fire Extinguisher System

4.7.2.1 Manual Operation

The extinguisher system is actuated by a push button switch for each zone, which is combined in one unit with the appropriate fire detector indicator light. Two fire extinguisher bottles, containing Freon 12B2, are provided, each having three outlets and each outlet is independently controlled by an electrically actuated valve. Each one of the three outlets from each bottle is piped to one of the three fire zones.

To operate the system the appropriate switch is pushed, and through a system of sequencing relays the associated fire bottle is triggered, thus discharging the extinguishing medium into the fire zone.

If the fire is not then extinguished the pilot may, by closing the "SECOND SHOT" switch, discharge the contents of the



second bottle into the same zone, or alternatively, should a fire occur in either of the other two zones the contents of the remaining bottle may be discharged by actuating the appropriate push button switch.

In the event of a fire in an engine zone, before the pilot presses the fire extinguisher button he should select the left or right low pressure cock switch to "Off". This action will energize the appropriate low pressure cock valve closed.

Power for the first shot for each area is supplied from the battery bus, therefore, in the event that the master switch is "OFF", power from the battery bus will be available to close the low pressure cocks and discharge the fire extinguisher bottle.

4.7.2.2 Automatic Operation

Under crash conditions, the crash or inertia switch will actuate the system, discharging the contents of one extinguisher bottle into both right and left engines, and the contents of the other extinguisher bottle into the hydraulic bay.

Power for this operation is also supplied from the battery bus.

4.8 Normal Canopy Actuation (Ref. Fig. 8)

Actuation of each canopy is effected by the operation of an electrical linear actuator containing load limiting switches.



These switches ensure full travel of the canopy before they operate to remove the D.C. supply to the actuator. In addition a control to energize the canopy seal pressurizing valve is incorporated.

Each canopy is controlled by a pair of double pole, double throw switches (with centre "OFF") in parallel, one of each pair is located in each cockpit and the other on the canopy arch for ground actuation.

These ground service switches are for normal service and will not override the safety latches in the cockpit. However, a mechanical emergency release is incorporated which may be externally or internally operated.

Interlocking relays are provided in the circuit to prevent the ground switches being actuated in opposition to those in the cockpit.

Both front and rear cockpit systems have limit switches, in series with the D.C. supply, to prevent energizing the actuators with the canopies locked. The limit switches are actuated when the latch is fully open.

The canopy seal pressurizing valve is actuated automatically, when both front and rear canopy latches are in the fully



closed position, by means of limit switches in the locks which are wired in series. Power is taken from the emergency D.C. bus.

Power for canopy actuation is supplied from battery bus so that the canopies can be opened or closed after the master switch has been turned "OFF".

The canopies should only be opened once and closed once on the aircraft battery during a single flight cycle, but once the master switch is turned on, power can be obtained from the starting cart or ground energizer, if the engines have not been started.

4.9 Control System - Missile Hydraulics

This system provides for the selection, lowering and retraction of the missile launchers and the jettisoning of missiles when necessary.

- 4.9.1 If the two forward missiles are selected, a release signal from the electronics system will open the wing and fin doors, lower the launchers, return a signal to the electronic system and close the wing and fin doors.

When the missiles are released, the doors are reopened, the launchers retracted to the secondary up position and the doors are reclosed.



- 4.9.2 A rear missiles release signal will lower and raise the rear launchers, sequencing the system as in Para. 1. In addition, a drag link door will be opened with the wing and fin doors, and which will not be re-closed until the launchers have been raised to the secondary up position.
- 4.9.3 For the "All Missiles" selection, the above sequencing will take place for both front and rear launchers, but all four launchers must be down before the forward missiles firing control signal is returned to the electronics system.

When both forward missiles are released the missiles interlock control will initiate the rear missiles firing sequence. Simultaneously the forward doors will be re-opened, and the forward launchers will retract as in Para 1.

When the rear missiles are released the rear doors will be re-opened, and the rear launchers will be retracted as in Para. 2.

- 4.9.4 The "Missile Hung" light will go on when the doors in any selected sequence are opened, and will go out when the applicable missiles are released or upon manual or automatic jettison.

For manual retraction of hung missiles, the light will remain on until the front wing and fin door and/or the rear drag link



door fully closed limit switch is actuated.

4.9.5 The automatic jettisoning system is controlled by the electronics portion of the sequencing system when the "Peace-War" switch, or link connection is in the automatic jettisoning position, otherwise the pilot will have a choice of either "Retract" or "Manual Jettison".

4.9.6 Operation of the retract switch will open the doors, raise the missiles and reclose the doors.

4.9.7 Operation of the "Manual Stores Jettison" switch will jettison all missiles remaining on the aircraft. If all missiles are on and the launchers up, all doors will be opened; the launchers will lower and the doors will re-close. The rear missiles will be jettisoned first and the empty launchers will be raised. When the drag link doors fully closed limit switches are actuated, the forward missiles will be jettisoned; the forward empty launchers raised and the doors reclosed.

Should the forward missiles have been fired and their launchers raised, manual jettison selection will only lower the launchers of the remaining rear missiles.

4.9.8 A forward and a rear ground service switch is provided. Each switch has a "Raise" and "Lower" selection and is spring loaded to centre "Off". The launchers may be raised or lowered with the missiles either on or off. The hydraulic and



electrical systems are so designed that, in the event of both forms of power being removed, the launchers and doors will remain in the last selected position.

4.9.9 Safety controls are incorporated as follows:

- (a) Manual jettison and cockpit retraction are not operative until the aircraft is off the runway.
- (b) Firing and automatic jettisoning of missiles can normally only be performed when all undercarriage doors are locked up.
- (c) Should the pilot have neglected to jettison the external tank, it will be automatically released when the firing trigger is actuated. The missile doors will not open until the tank has dropped, and should it fail to do so, the pilot will receive a warning signal.
- (d) When manual jettisoning is selected, the external tank, if still on the aircraft, will be released before the missiles.
- (e) Firing and jettisoning lines to the missiles can be broken by means of a disconnect plug.

A ground test switch is provided to override the undercarriage safety controls.

4.9.10 The pack sealing valve is energized, through the actuation of the pack service panel door limit switch, from the main D.C. bus. This same source of power is used for a portion of the ground service control, hence the external supply must be



plugged in for ground operation of the launchers.

- 4.9.11 Emergency D.C. supply is used for actuation of the doors, launchers and jettison control with separate circuitry for forward and rear launcher operation and jettison control.

4.10 Air Conditioning System

4.10.1 Cockpit Temperature Control

The cockpit temperature is controlled by regulating the mixture of hot air with cooling air which is supplied to the cockpit. The temperature may be regulated by the pilots' cockpit temperature selector within the range of 40°F to 80°F.

This temperature control is achieved by a valve, located in the hot air supply duct, which is controlled by a temperature sensing system. The sensing system is a balanced bridge circuit with sensing units located in both inlet and outlet ducts.

4.10.2 Electronic Equipment Temperature Control

This system is similar to the cockpit control system, but has no manual control.

4.10.3 Defogging

A de-fog switch is fitted in the pilots' cockpit to override the temperature sensing system, and provide inlet air at a temperature of 95°F to disperse fogging.

4.10.4 Emergency Operation

At high speeds, the failure of cooling air flow to the equipment



requiring cooling and to the cockpit, will result in critically high temperatures due to kinetic thermal effects. To lower the temperature, speed must be reduced immediately and the pilot's air emergency supply switch, switched to the "ON" position.

The "ON" position will close the air-conditioning system shut off valve and the radar nose valve. The left ram air valve and left reverse flow valve will both open when the controlling thermostat is 100°F or below.

4.10.5 In the case of failure of either the cockpit or radar temperature controller, power to the respective valve (as applicable) will be cut, permitting the valve to return to the closed position.

4.10.6 Ground Operation

- (1) Satisfactory ground operation is automatically provided for, by the operation of a scissor switch on the right undercarriage, which opens when the weight of the aircraft is on the undercarriage.
- (2) This switch opens both the left and right reverse flow valves and supplies air, bled from the engine intake ducts, to the air-conditioning system which maintains stable operating conditions when the aircraft is not in flight. Simultaneously the cockpit inlet valve will be closed.



4.10.7 Ground Service

- (1) When the external air supply is connected to the aircraft, the cockpit inlet valve will be opened, and the air-conditioning system valve will be closed.

4.11 Flight Services and Master Warning

4.11.1 Master Warning System

- 4.11.1.1 The complete system consists of the pilots' warning light panel, the master warning lights, the fire extinguisher warning lights and lights in the radar scope.
- 4.11.1.2 Two master warning lights are provided on the pilots' main instrument panel. These lights are used in conjunction with the individual system warning lights, and provide a master indication of any trouble existing in the systems. The master warning light may be turned off by pushing a reset switch on the warning light panel, however, the system warning light will remain on until the fault is cleared.
- 4.11.1.3 The pilots' warning light panel consists of 38 amber warning lights, a master warning light reset switch, a push to test switch and a dimmer switch. Each light is identified on the lens as to the system it indicates, and a light is supplied for each of the following services:
 - (1) L or R fuel transfer "OFF".
 - (2) Tank empty/jett. fail.
 - (3) R/H aircraft fuel low level.

- (4) L/H aircraft fuel low level.
- (5) Hydraulic bay fire - not located on warning light panel.
- (6) R/H engine fire - not located on warning light panel.
- (7) L/H engine fire - not located on warning light panel.
- (8) R/H engine oil pressure.
- (9) L/H engine oil pressure.
- (10) R/H engine fuel pressure.
- (11) L/H engine fuel pressure.
- (12) R/H low rotor overspeed.
- (13) L/H low rotor overspeed.
- (14) L or R engine emergency fuel control "ON".
- (15) Missile hung up.
- (16) Radar overheat.
- (17) Missile locked "ON" - located in radar scope (non master)
- (18) Missile locked "OFF" - located in radar scope (non master)
- (19) R - P axis out.
- (20) Damping out.
- (21) Emergency damping on.
- (22) Cabin pressure.
- (23) Air condition system.
- (24) R/H engine bleed fail.
- (25) L/H engine bleed fail.
- (26) Battery use.
- (27) L or R D.C. fail.



- (28) R/H alternator fail.
- (29) L/H alternator fail.
- (30) Ice warning.
- (31) Flying control hydraulic - A.
- (32) Flying control hydraulic - B.
- (33) Utility hydraulic.
- (34) Emergency brake hydraulic.

4.11.1.4 The master warning control unit accepts individual warning signals to operate the warning lights in the following manner:

- (a) On receipt of a fire signal, the appropriate fire warning light will go on together with the red master warning light.
- (b) On receipt of a signal from either flying control hydraulics system A or B, the associated amber light on the pilots' warning light panel and the master amber warning light are activated. Should systems A and B fail simultaneously or consecutively, both lights on the pilots' warning panel will light and also both the red and amber master warning lights.
- (c) When engine emergency fuel is selected, the light on the pilots' warning panel is activated, a reminder to the pilot that emergency fuel has been selected. No master warning light is lit.
- (d) The remaining lights listed will be energized simultaneously with the amber master warning light on receipt of



their particular warning signal, except for the missile locked ON or OFF lights which are not connected to the master. The master red and amber warning lights are dual units having two filaments each in parallel for reliability. The bail out light and the light in the under-carriage position selector lever are also connected to test and dimming circuits.

On dimming selection, resistors are connected in series with all output signals except the three fire detection lights.

4.11.2 Turn and Slip Indicator:

This is a conventional circuit powered from the emergency D.C. bus.

4.11.3 Bail out Signal:

A switch, for use in emergency, is located in the pilots cockpit. When the switch is operated a red warning light and a signal buzzer will be energized to warn the navigator to bail out. A green light will also be energized in the pilot's cockpit. Power to the lights and buzzer is fed from the emergency D.C. bus, through the navigators seat limit switch.

The extinguishing of the green lights in the pilot's cockpit indicates to the pilot that the navigator has bailed out.



4.11.4 Hydraulic Pressure Warning:

Four warning lights located in the pilots' cockpit are as follows:

- (a) Flying control system "A"
- (b) Flying control system "B"
- (c) Utility system
- (d) Emergency brake

In flying control systems "A" and "B" and the utility system, the lights are energized by means of pressure switches when the hydraulic pressure drops below 1000 psi. and are de-energized when the pressure subsequently rises to 3000 psi.

In the emergency brake system, the light is energized by means of a pressure switch when the hydraulic pressure drops below 1,600 psi. and de-energized when the pressure rises to 3000 psi.

4.11.5 Pitot Heat:

A heater is fitted to the pitot head located on the top fin. The power is supplied from the 115/200 VAC bus through a test switch. The test circuit incorporates a resistance in series with a green light and the heater element.

4.11.6 Speed Brakes:

The control for the speed brakes, which are hydraulically actuated, is provided by a double acting electrically operated control valve. A single pole double throw switch, located in

the right hand throttle handle in the pilots' cockpit, is used to control this valve. The mid position of the switch is marked "HOLD" and the positions, to either side, are identified "IN" and "OUT". When this switch is moved to the "IN" or the "OUT" position, the corresponding coil of the valve is energized from the emergency D.C. bus, resulting in movement of the speed brake to the extreme position in the selected direction. Any intermediate position between fully extended or fully retracted can be obtained by moving the switch to "HOLD" when the speed brake reaches the desired position.

4.11.7 Pilots Control Surface Position Indication:

When the control surfaces are moved (AILERON, ELEVATOR, RUDDER), the trim indicator is powered through variable resistances. The trim indicator is located on the pilots' console panel.

4.12 Cockpit Lights (Ref. Fig. 12)

Five lighting circuits for each cockpit provide power to:

- (a) Main instrument panel instrument lights (RED)
- (b) Main instrument panel & console edge lights (RED)
- (c) Console flood lights (RED)
- (d) Main instrument panel high altitude console flood lights
(Amber Flood)
- (e) Emergency flood and map lights



The circuits may be turned "ON" or "OFF" independently. Circuits "a", "b" and "c" have individual dimming control through variable transformers. Each emergency flood light has a dimming feature incorporated. Circuits "a", "b" and "c" are fed from the 115 volt main A.C. bus, circuit "d" from the 28 volt D.C. main bus and circuit "e" from the 28V D.C. emergency bus.

4.13 External Lights (Ref. Fig. 13)

4.13.1 Landing and Taxiing Lights

Two AN3129-4523 lamps are fitted on the nose undercarriage; one is fitted on the steering portion for "Taxi" purposes and the other on the fixed portion of the leg.

The landing and taxiing lights are controlled by a double pole, double throw switch with a centre "OFF" position. The control is through the undercarriage door "UP" relay to prevent the landing and taxiing lights being turned on with the undercarriage up.

One side of the control switch is connected to a single pole, single throw relay which controls the landing light, the other side controls the taxi light through a similar relay.

The switch is marked "TAXI", "OFF" and "LANDING". With the undercarriage down and "LANDING" selected, both taxi



and landing lights will be illuminated; when "TAXI" is selected, only the taxi light will be on. Power is supplied from the 28 volts D.C. shedding bus.

4.13.2 Navigation Lights

The navigation lights, consisting of the right and left wing tip lights and the two fin tips lights, are controlled by a flasher unit through a four pole double throw switch with a centre "OFF" position. Power is supplied from the main D.C. bus.

The control switch has two "ON" positions marked "STEADY" and "FLASH". When the "STEADY" position is selected all lights are turned on, and when the "FLASH" position is selected the two wing tip lights and the white fin tip light will be on together and will flash alternately with the red fin tip light, each being on .75 seconds and off .75 seconds alternately.

4.14 Engine Anti-Icing and Duct De-Icing Systems (Ref. Fig. 3 & 14)

4.14.1 General

The anti-icing and de-icing installation is divided into three parts:

- (a) Ice detecting
- (b) Duct intake ramps and lips de-icing
- (c) Engine anti-icing



The power supplies to the above systems are as follows:

- (a) 28 Volt D.C. supply from the de-icing D.C. bus to the ice detectors and controls for both engine anti-icing and duct de-icing systems.
- (b) 115/200 volt three phase supply from the left and right de-icing buses to the respective distributor for heating the parting strips and shedding areas in the duct de-icing system.

4.14.2 Ice Detecting

General

The detection of ice formation is accomplished by two electrically heated ice detectors. The units are identical and one is mounted on the lip of each engine intake duct.

The ice detector is a unit containing a pressure switch, four relays, three resistors, and mounting two electrically heated probes which protrude into the air stream. One probe is continuously heated whenever the de-icing D.C. bus is energized and provides a reference static pressure. The other probe has a number of small holes exposed to the air stream, on the forward side, and under normal conditions of flight will record a positive pressure in respect to the reference pressure recorded in the reference pressure probe.

When icing is encountered ice will form over the holes in the



detector probe and reduce the pressure below that of the reference probe. This condition is sensed by the pressure switch which operates to send a signal to the de-icing controller and supply power to the detector probe heater. The heater rapidly clears the probe of ice and re-establishes a positive pressure balance. If icing conditions continue, the icing and de-icing cycle of the detector probe is repeated continuously, thereby transmitting pulses to the de-icing controller at a rate directly proportional to the rate of icing.

4.14.3 Duct De-Icing System

De-icing of the intake ducts is accomplished by electrically heated rubber ice protectors which are automatically controlled. The units which make up this system, and their operation, are described below.

4.14.3.1 Controller

The de-icing controller is supplied with signals from the ice detector as described in para. 4.14.2 and interprets them to control both the duct de-icing and engine anti-icing systems.

On receipt of the first ice detector signal, the controller:

- (a) turns on the engine anti-icing system.
- (b) energizes the parting strips on the ice protectors.
- (c) commences a count of icing signal.

When the count of icing signals reaches a pre-determined

number, which may be preset in the controller between the limits of 4 to 12 signals, the controller:

- (a) starts the shedding cycle of the duct ice protectors.
- (b) recommences the count of icing signals.

Upon completion of the shedding cycle, the controller:

- (a) starts a new shedding cycle if the preset number of signals (or more) have been received since the commencing of the shedding cycle.

or (b) continues the signal count until the preset number of signals has been received and then starts a new shedding cycle.

or (c) after a preset time (variable between 40 to 160 seconds) elapses from (i) to receipt of the last icing signal or (ii) the commencement of the last shedding cycle, will initiate a final shedding cycle at the conclusion of which both the engine anti-icing and the duct de-icing systems are shut off.

Also incorporated in the controller is a provision for adjusting the shedding time for each shedding area between 4 and 12 seconds.

4.14.3.2 Distributor

The distributor supplies 115V A.C. power to the heated areas of the rubber ice protectors in the proper sequence and as directed by signals from the controller.

4.14.3.3 Ice Protectors

The ice protectors are made of rubber and have wires embedded below the outer surface to carry the heating current. They are divided into two types of heated areas as appropriate to their location as follows:

- (a) parting strips, which are continuously heated under icing conditions and thus kept free of ice at all times.
- and (b) shedding areas, which are intermittently cycled according to the icing conditions encountered.

The protectors are prevented from overheating by thermostats provided on the installation, which interrupt the heating current through the distributor for the shedding areas and, through a relay for the parting strips.

4.14.4 Engine Anti-Icing System

Engine anti-icing is accomplished by the use of engine bleed air. Operation of the system is started automatically by the controller through the actuation of an air supply valve. The system functions continuously during icing conditions. (Ref. Engine Services).

4.15 Radome De-Icing, Windscreen and Canopy Anti-Icing

4.15.1 Radome Ice Protection

A solenoid operated shut-off valve is controlled automatically by a signal from the forward ice detector, through a "hold-on" relay. This detector is additional to, and identical to the ice



RAMP & INTAKE DE-ICING LOADING

Boot No.	Shedding Area	Load V. A.	Parting Strip No.	Load V. A.
1	1 *	1670	1	480
2	2 *	3280	2	122
	3	4950	3	388
	4	4950	4	140
	5	4950	5	148
			6	95
			16	375
3	7 +	2550	8	123
	8	4950	9	232
			12	100
			17	47
4	11	4950	11	100
			13	300
5	10	4950	10	100
			14	300
6	7 +	2400	7	123
	9	4950	15	232
7	6	4950		
			TOTAL	8355

* Cycled together as one shedding area.

+ Cycled together as one shedding area.

Loads in table are calculated on the following watt dissipation.

20 watts/square inch for parting strips.

12 watts/square inch for shedding areas.



detectors used in the engine anti-icing and duct de-icing systems.

When an icing signal is received, the solenoid valve will be opened for approximately 1.5 seconds, spraying de-icing fluid on the external surface of the radome. At the end of this period this valve will close and an air valve, supplying purging air from the pilots anti-G line, will open for approximately 23 seconds. When the system operates, a signal will be sent to the ground check annunciator box which will notify the ground service crew that de-icing fluid has been consumed. In order to prevent loss of fluid, this system is de-energized when the aircraft is on the ground, however, a check of the system can be made by operating the ground test override switch and then functioning the ice-detector.

4.15.2 Windscreen and Canopy Anti-Icing

Anti-icing of the pilots' windscreen and canopy and the navigators' canopy is accomplished by passing current through an oxide coating which has been sprayed on the inner surface of the outer glass lamination of the panels. Resistance element sensors, part of a bridge system, are built into the glass panels to control the temperature. In the event of an overheating condition, the control system will cause the panel to be de-energized. The system is energized continuously when

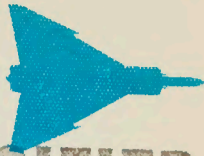

UNCLASSIFIED

the aircraft master electrical switch is selected to "on" and
the power buses are energized.

5. Description of Equipment

5.1 A.C. Generator, Controls and Transformer Rectifier

To be issued later.

APPENDIX 1
PARTS TO AVROCAN SPECIFICATIONS

UNIT	MANUFACTURER	MFG. DWG. OR PART NO.	AVROCAN SPEC.	SPEC OR SPEC. DWG.	CO. STD. DWG.
Battery 15 AH	Saft	22023	E 209	7-1152-11	-
Flasher - Position Lights	Lucas-Rotax	DEV. 5001	E 224	-	CS-F-106
Wing Tip Lights	Grimes (Aviation)	D8020	E 229	-	1 & 2 CS-L-129
		D7067			
		SK538			
Fin Tip Lights	Soderberg	S1124A	E 229	7-1183-11 & -12	
		S1124-4A			
		A3084R-BX			
Switch (Fire Ext) Push Button	Hetherington	-	E 287	-	CS-S-155
Inertia Switch			E 290	-	CS-S-150
Instrument Transformer	Can. Atlas Trans	-	E 291	7-1152-31	-
Rotary Switch (Refuel)	C-H	7262K11	E 295	-	CS-S-149
Transformer - Variable Voltage	Can. Atlas Trans	-	E 352	-	CS-T-134
Control Box - Master Warning			E 376	7-1152-12	-
Switch (Relight)	Hetherington	C1006	-	MIL-S-6743	CS-S-151
Switch Limit. Canopy Act.	M-H	-	-	MIL-S-6743	CS-S-152
Actuator (Limit Switch)	M-H	JE5	-	MIL-S-6744	CS-A-105
Relay 2PDT 10 Amp	U. S. Relay	-	-	MIL-A6106A	CS-R-122
				Type 1. Class B	
Fuse	Burndy (N. E. Co)	-	E 240	-	CS-F-107
Fuse Holder	Burndy (N. E. Co)	-	E 241	-	CS-F-108
Connector - Lanyard Release	Garrett Corp.	9500 A5V	E 307	-	CS-C-142
Starting Control & Intercomm	(Wiggins)	9500 A6V	-	-	
Indicator Light	Marco	-	-	MIL-I-3661	CS-I-108
Relay 50A. SPDT Class A	Can. Diaphlex	650-4063	-	MIL-R-6106A	CS-R-128
External Supply Receipt & Cover	Albert & J. M.	-	E 345	-	CS-R-127
Switch 3 POS Slide	Anderson Mfg. (Powerlite)	-	-	MIL-S-6743 & 6744	CS-S-153
	M-H	X111618	-	-	
Indicator Light (Miniature)	Dialite	-	E 318	-	CS-I-107
Panel - Landing Gear Control		-	E 279	7-1152-8	-
Indicator - Dual Warning	Korry	204BPRL	-	MIL-I-3661	CS-I-109
		204BPAL			
Generator 208/120V.A.C .400 Cycle	-	-	E 500	-	-
Control Unit & Transformer Rectifier	-	-	E 500	-	-

APPENDIX 2A REVIEW OF THE ENGINEERING DECISIONS ON BATTERY SELECTION
FOR THE CF-105 AIRCRAFT1. Introduction

A nickel cadmium battery was selected for the CF-105 aircraft. This selection was largely based on the reduction of weight and the ease of maintenance that a nickel cadmium battery would provide over the more commonly used lead acid battery. The selection of this type of battery has been queried by the RCAF in letters Ref. No. S-1038-105-8 (ACE-1) and 1038-CF105-80 (AMTS/DIE ENG). The objections raised to the present installation appear to be:

- (a) that the battery has been incompletely evaluated and qualified by the U.S. Navy, and
- (b) that the batteries of this type are prone to self destruction at aircraft operating temperatures.

It was also pointed out that a quick disconnect type of battery connector was desired. Accordingly, this review of the present situation is presented so that the full details of the present installation may be known.

2. The Qualification and Reliability of Nickel Cadmium Batteries2.1 Qualification Status

A nickel cadmium battery of this type has been electrically qualified as indicated in a letter dated 7th, December 1955 Ref. AER-EL-501/67, Department of the Navy Bureau of Aeronautics, Washington 25, D.C. A copy of this letter has

UNCLASSIFIED



been sent to Mr. D.M. Fraser, 1070 Birchmount Rd., Toronto 16, Ontario, and its contents state that the battery meets the electrical qualification test requirements of MIL-B-8565.

2.2 Service Use

This type of battery has given 200 hours of trouble free operation in a CF-100 MK.4 aircraft and it is understood that aircraft companies in France, England, and in the United States have reported good performance and reliability of similar units.

2.2.1 Service Difficulties

There are no known records of the so called "vicious cycle" that have not been associated with overcharging of the battery. However, it may be noted that this problem also exists with the lead acid type of battery but in that case the temperature rise on overcharge is not as high as in the nickel cadmium type. The higher temperature rise of the latter is due to the low internal resistance which makes possible its superior high discharge rate characteristics.

3. Battery Selection

A 15 ampere-hour battery is required for the CF-105 aircraft. The nearest standard size is the AN 3151, a 24 A.H. lead acid type battery for which a dimensionally equivalent nickel cadmium type of 22 ampere hours capacity is available. However, the use of the 22 ampere hour battery would entail a weight penalty of 10 to 12 lbs. over the 15 A.H.

nickel cadmium battery presently selected.

4. Nickel Cadmium Battery Temperatures

4.1 General

The early model of the nickel cadmium battery required a wiring connection to the generator controls to control the voltage at the battery terminals. Later, this arrangement was modified and a thermocouple was incorporated in an outer battery cell to control a relay which isolated the battery from its charging circuits when overcharging caused the outer reference cell to reach 135°F , which is equivalent to an inner cell temperature of 160°F .

4.2 Characteristics of the Battery Temperature Rise

Battery temperature does not start to rise until the battery reaches 100% of full charge as is shown by a temperature rise versus % overcharge curve (Fig. 1) furnished by the battery manufacturer. This curve indicates a rapid temperature rise if a high charging rate is maintained after the battery comes up to full charge.

However, this temperature rise may be prevented by:

(a) completing the final charging of the battery at a low rate,

or

(b) by charging at a voltage which is less than the full charge voltage of the battery.



5. Anticipated Temperatures of the Nickel Cadmium Battery as Installed in the CF-105

5.1 Electrically Induced Temperature

As the no-load full charge battery voltage is 29 volts and the aircraft charging voltage is 27.5 ± 1 volt, there appears to be no danger of overcharging and consequently overheating the battery.

5.2 Ambient Temperature

The battery is installed in a compartment whose ambient temperature is controlled by the air conditioning system to 160°F. However, to take full advantage of the nickel cadmium batteries' characteristics it was decided to provide a special cooling facility to maintain the battery itself at 80°F.

6. Terminals

The battery will be fitted with a quick disconnect type of connector similar to that used on the Convair B58. However, the maintenance problems connected with the use of nickel cadmium batteries appear to be far less than those associated with the lead acid type, and for this reason the nickel cadmium battery did not appear to require removal as frequently as the other type. In particular, the lead acid battery was frequently removed for servicing for any one of the following conditions:

- (a) exposure of the aircraft to nominal low temperatures often required replacement of a cold battery with a warm one, especially when an electrical starter was used.

- (b) routine inspecting involving cleaning and corrosion prevention due to spillage, leakage and spraying of the electrolyte.
- (c) routine specific gravity adjustment of the electrolyte, entailing bench checking.
- (d) on some aircraft installations, the battery must be disconnected to disable the canopy ejection mechanism when the aircraft is hangared.

The nickel cadmium battery installation as proposed for the CF-105 aircraft will not require battery removal for any of the above reasons. This aid to ease of maintenance of the aircraft is brought about through the following characteristics of the nickel cadmium battery and its installation.

- (a) While the low temperature characteristics of the nickel cadmium battery are superior to those of the lead acid type, should it have been subjected to a "Cold soak" at temperatures below approximately -15°F , it will be necessary to replace the battery if the aircraft is required for immediate flight.
- (b) the battery is a sealed unit and so requires no electrolyte maintenance.
- (c) the canopy and seat ejection mechanisms of the CF-105 aircraft are not electrically operated.



SAFT BATTERY - VOLTABLOC VO-15 EFFICIENCY STUDY

EMERGENCY D. C. BUS FLIGHT LOADING

SERVICE	AMPS
YAW DAMPING	1.36
TURN & SLIP	.20
V & H REF. ERECTION COMPUTER	.73
INTEGRATED DIRECTION INDICATOR	1.45
U. H. F. ARC-52 (XN-4)	1.00
I. F. F. APX-19	1.80
SPEED BRAKES	.70
INTERPHONE AIC-10	2.55
CANOPY SEAL	1.00
MISC. RELAY CONTROL	.80
RELIGHT 12A/ENGINE FOR 20-30 SECS	.70
ENGINE SERVICES	4.00
LANDING GEAR DOWN INDICATION	.50
EMERGENCY FLOOD LIGHTS	.60
PITCH TRIM (1A FOR 20 SECS OVER 20 MINS)	.02
FIRE DETECTION	1.00
CONTINUOUS LOAD	18.41A

Additional connected loads, not normally used and of short duration:

- FIRE PROTECTION
- ENGINE EMERGENCY FUEL SELECTION
- STORES JETTISON
- CANOPY ACTUATION
- BAIL OUT INDICATION

EFFECT OF TEMPERATURE ON TIME OF OPERATION

Calculating on a basis of an 18.5 amps continuous load.

AMPS	TEMPERATURE	MINUTES OF OPERATION
18.5	+68°F	48
18.5	-32°F	46
18.5	-4°F	34

2551-105-1

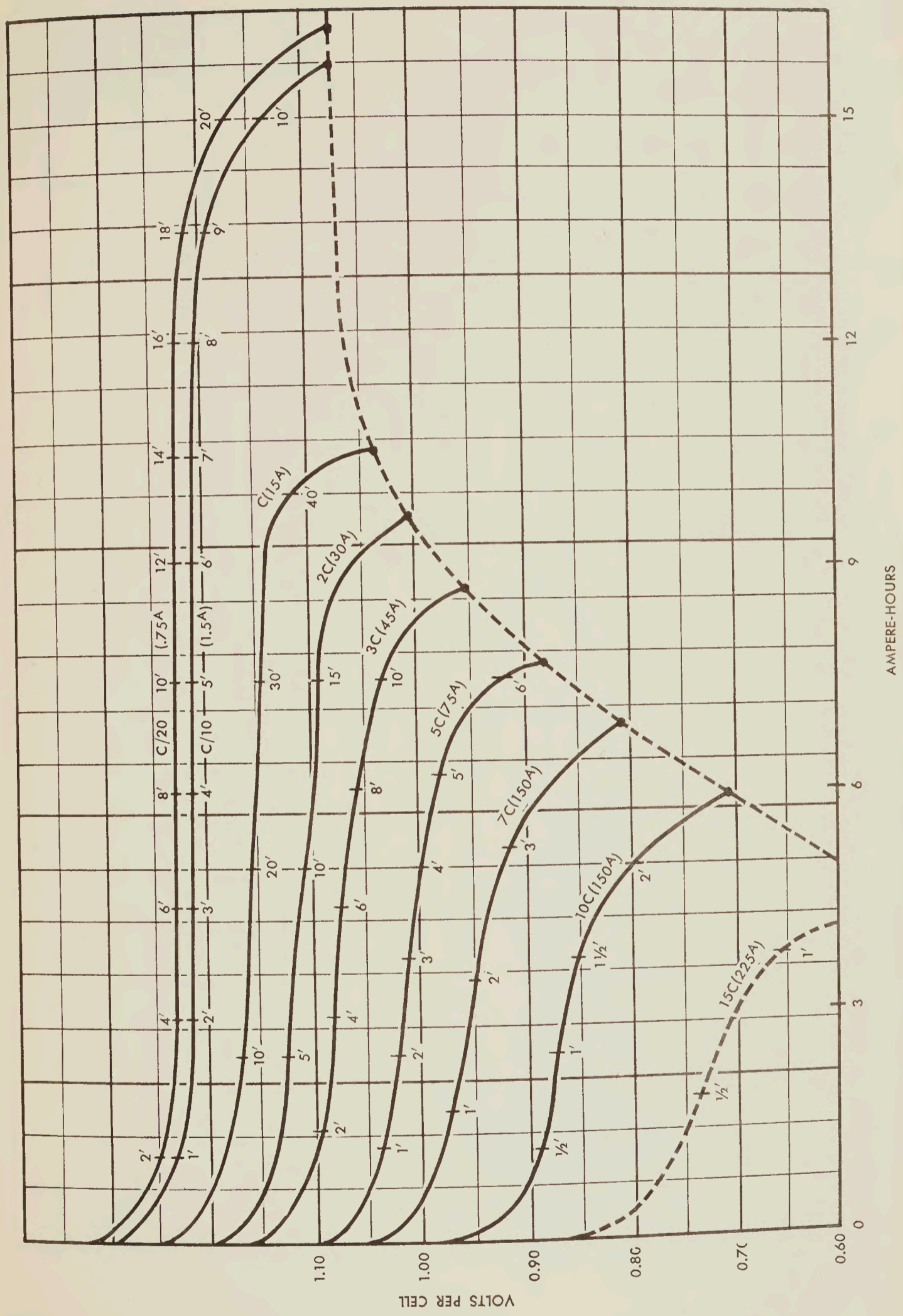

MAY/57

VOLTABLOC VO 15 CONTINUOUS DISCHARGE 24 HOURS AFTER CHARGE
AT AMBIENT TEMPERATURE AT -20°C(-4°F)

/27



2552-105-1

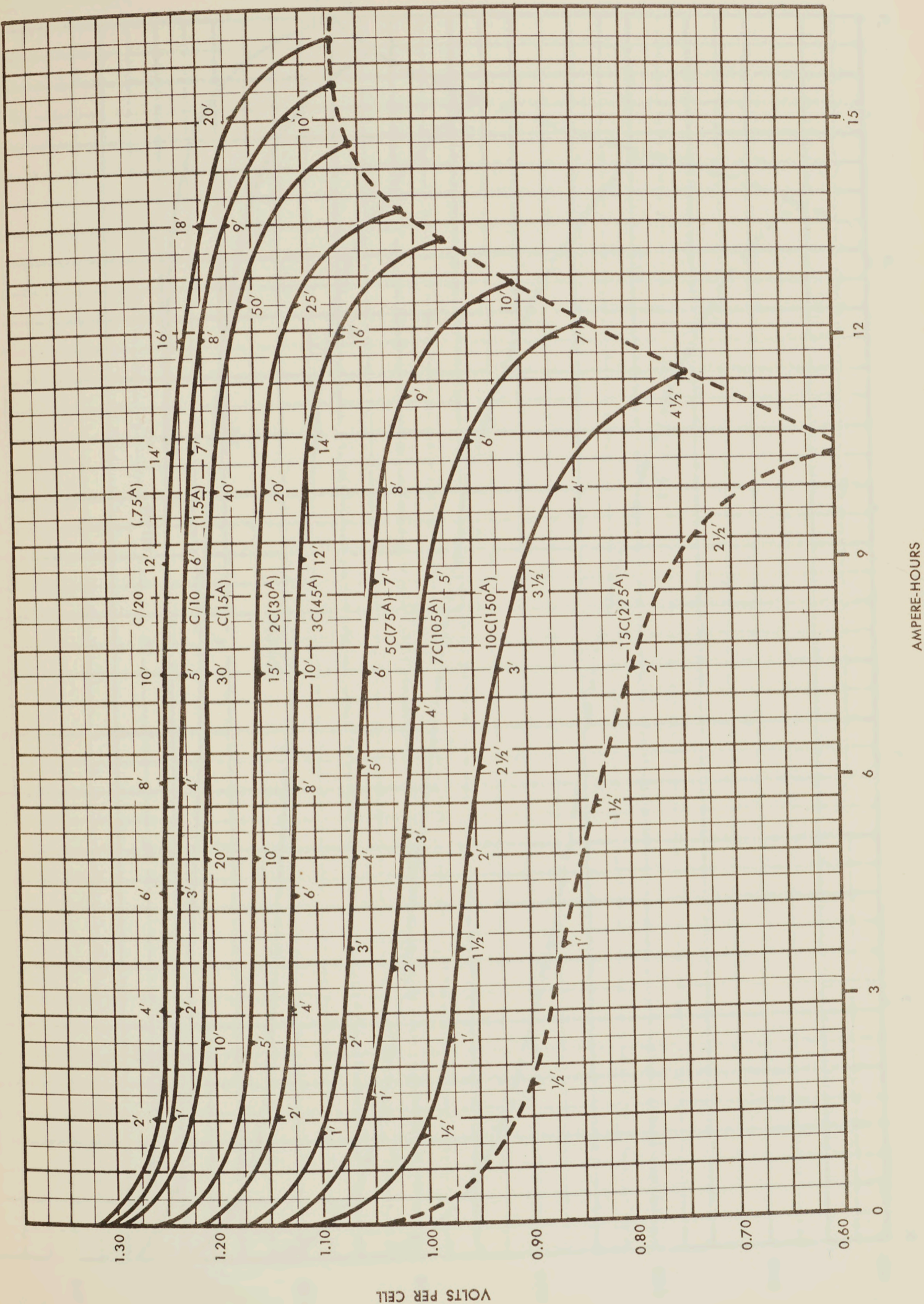

MAY/57

VOLTABLOC VO 15
CONTINUOUS DISCHARGE 24 HOURS AFTER CHARGE AT AMBIENT TEMPERATURE 0°C (32°F)

/27

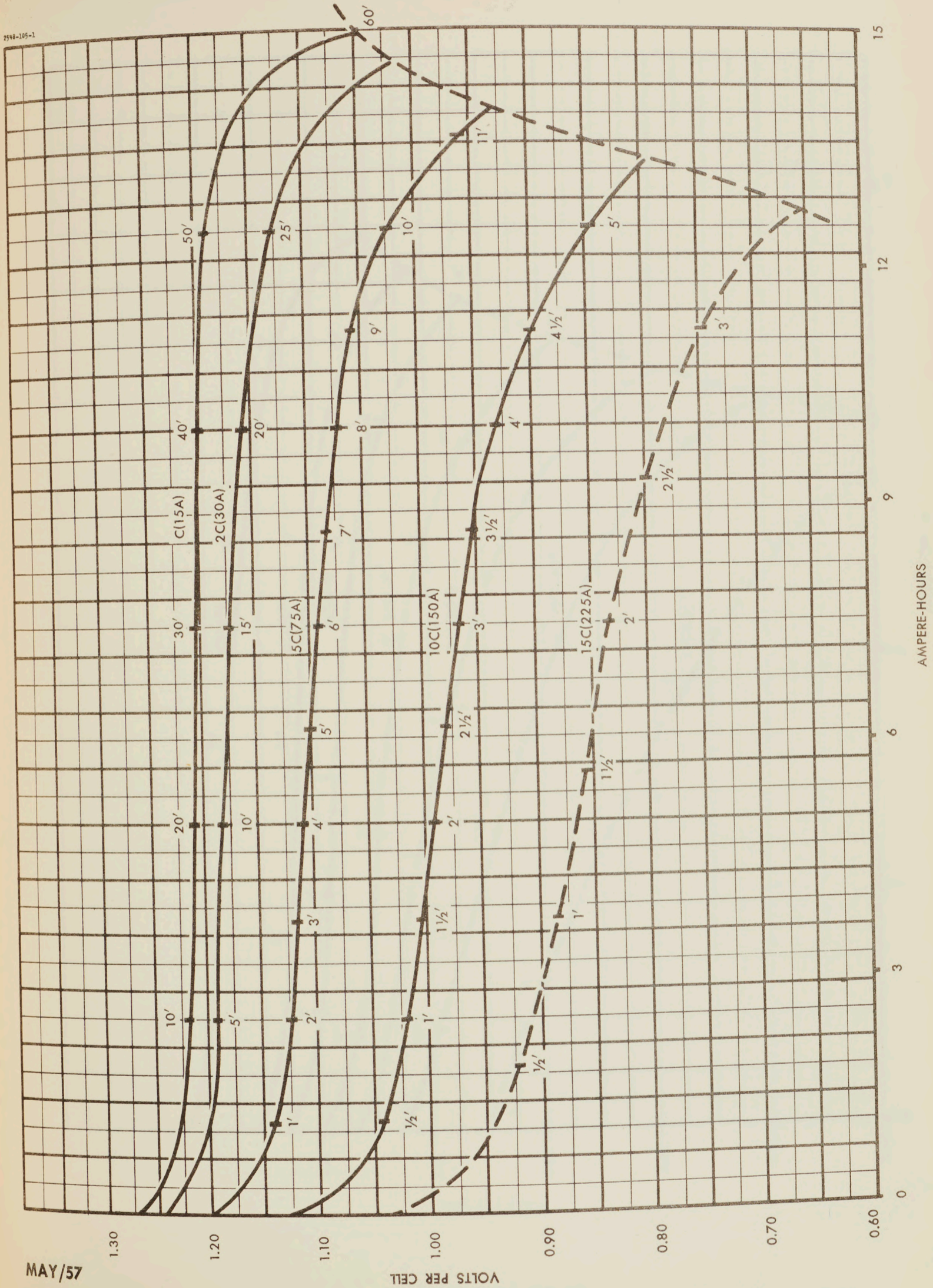

MAY/57

VOLTABLOC VO 15 CONTINUOUS DISCHARGE AT 20°C(68°F)

/27

2595-105-1

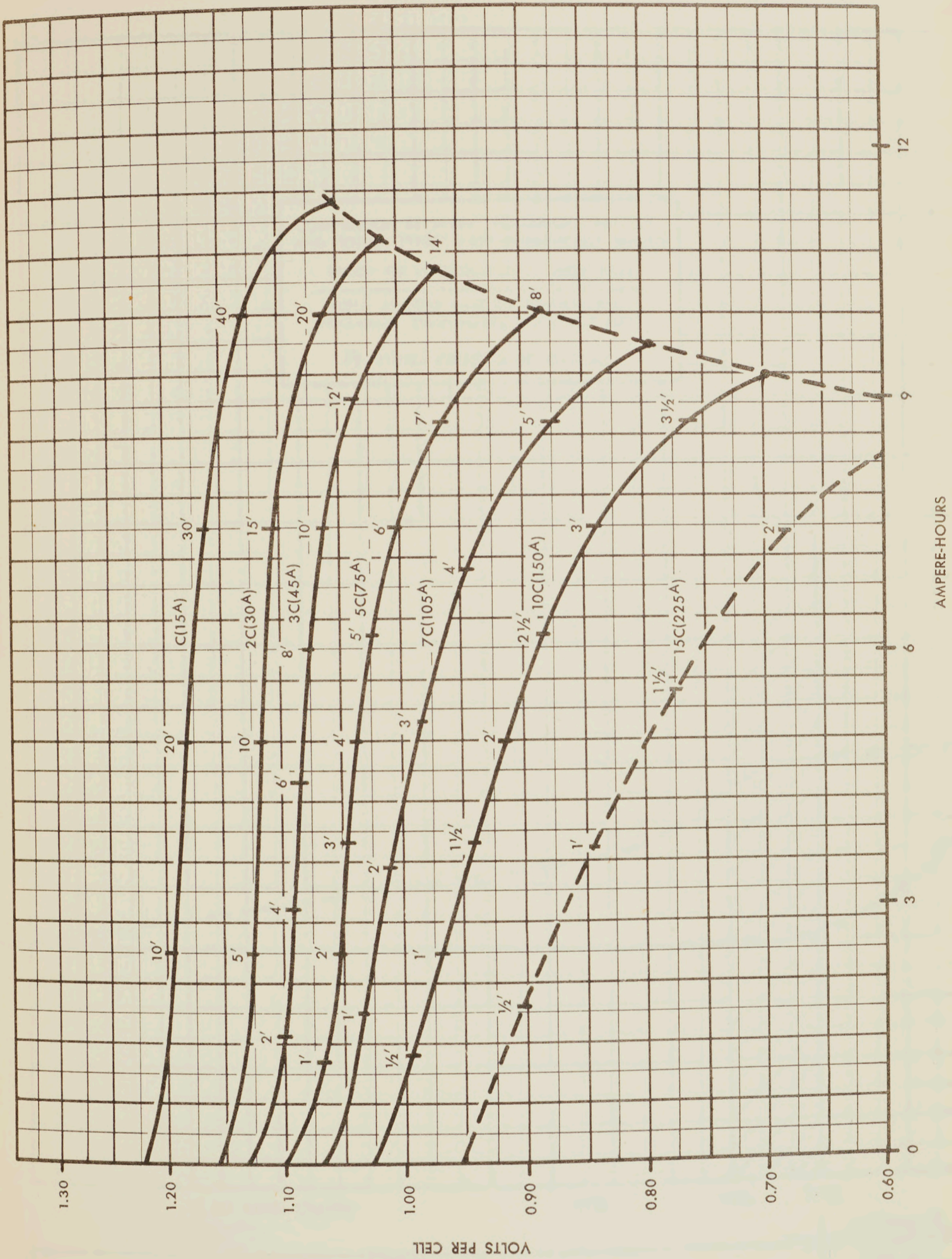

MAY/57

/27

VOLTABLOC VO 15
CONTINUOUS DISCHARGE 5 HOURS AFTER CHARGE AMBIENT TEMPERATURE 45°C(113°F)

2550-105-1

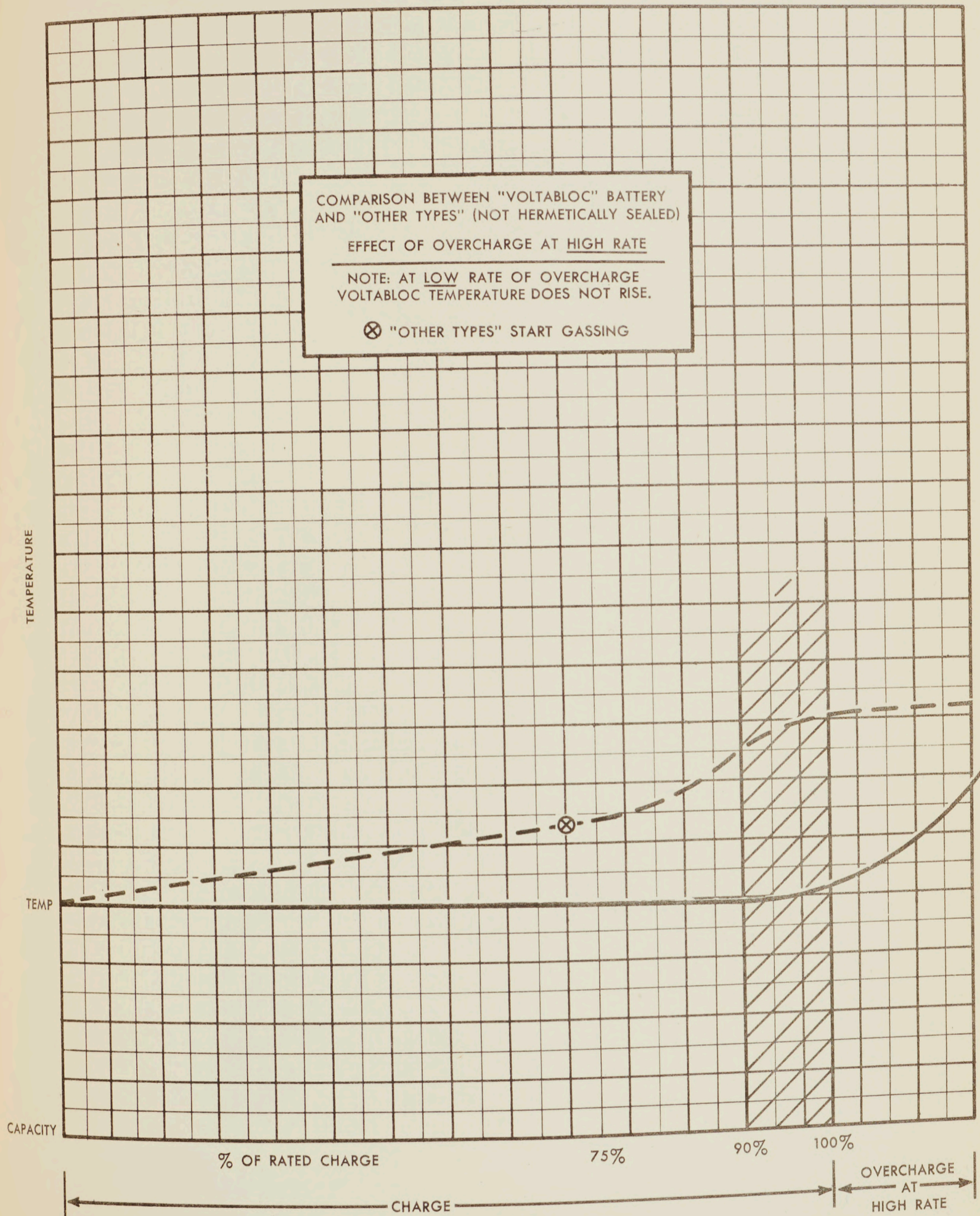

MAY/57

/27

EFFECTS OF OVERCHARGE AT HIGH RATE

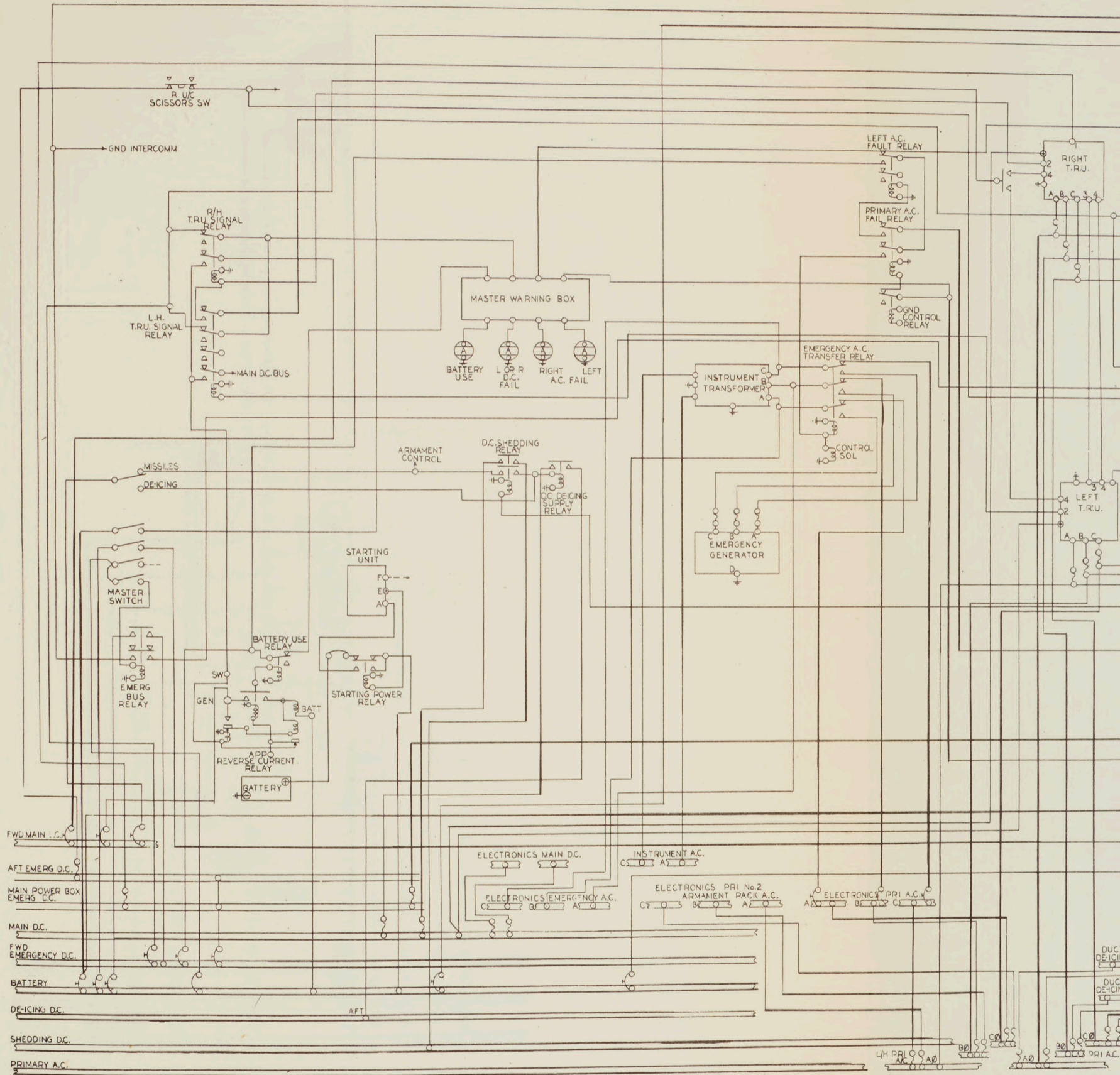

FIG. 1 POWER SYSTEM

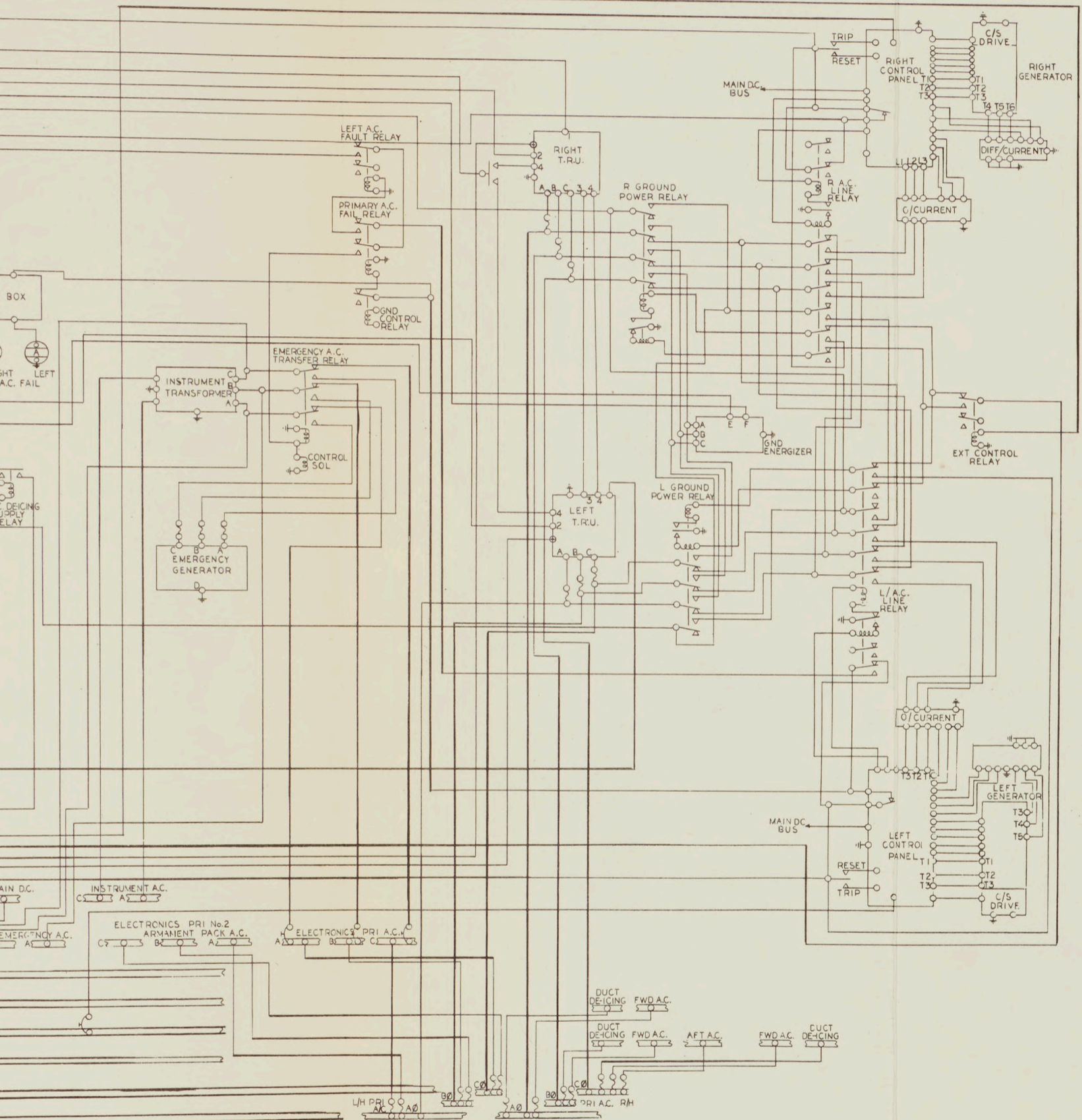

FIG. 1 POWER SYSTEM

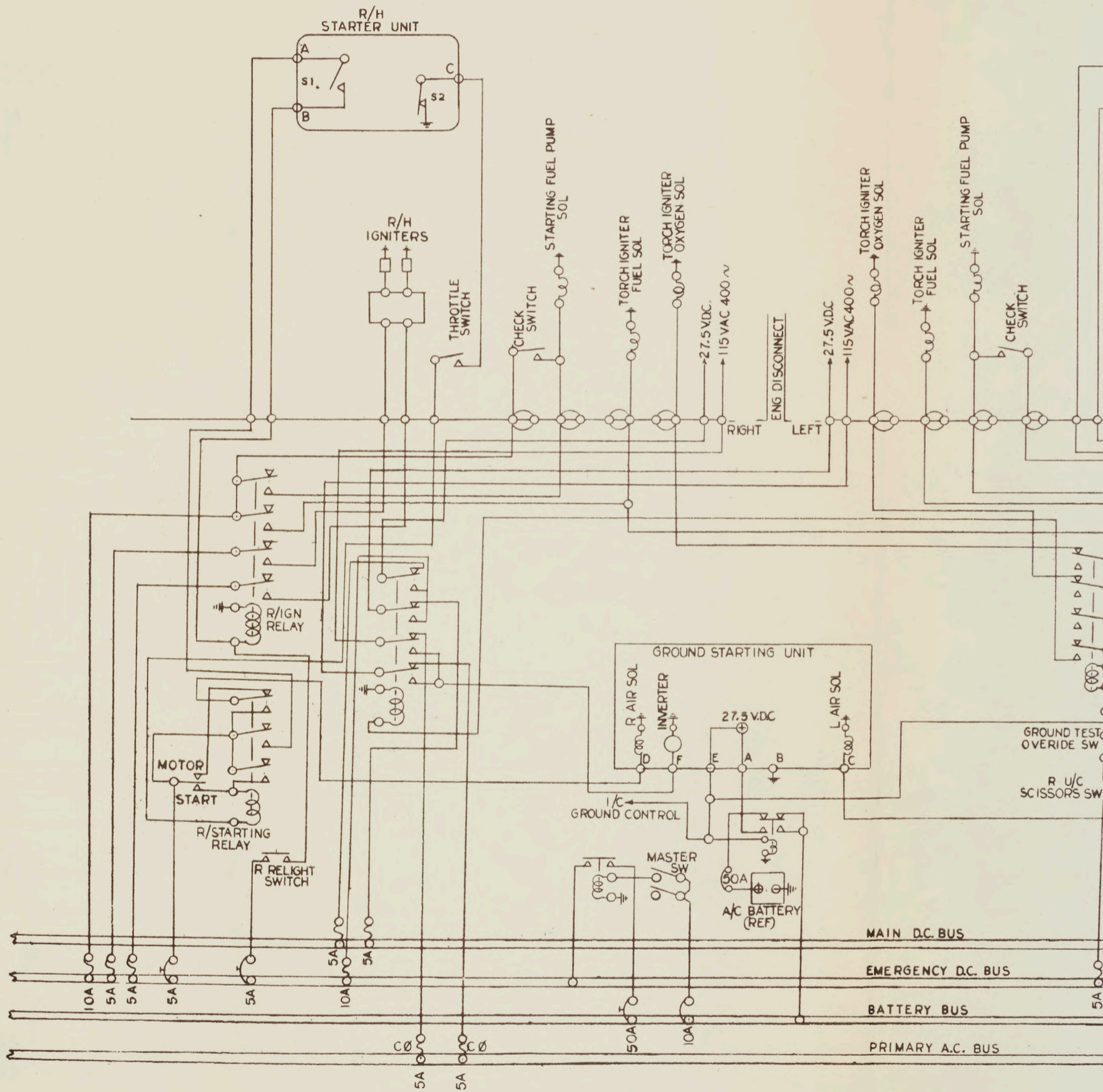

FIG. 2 STARTING AND IGNITION

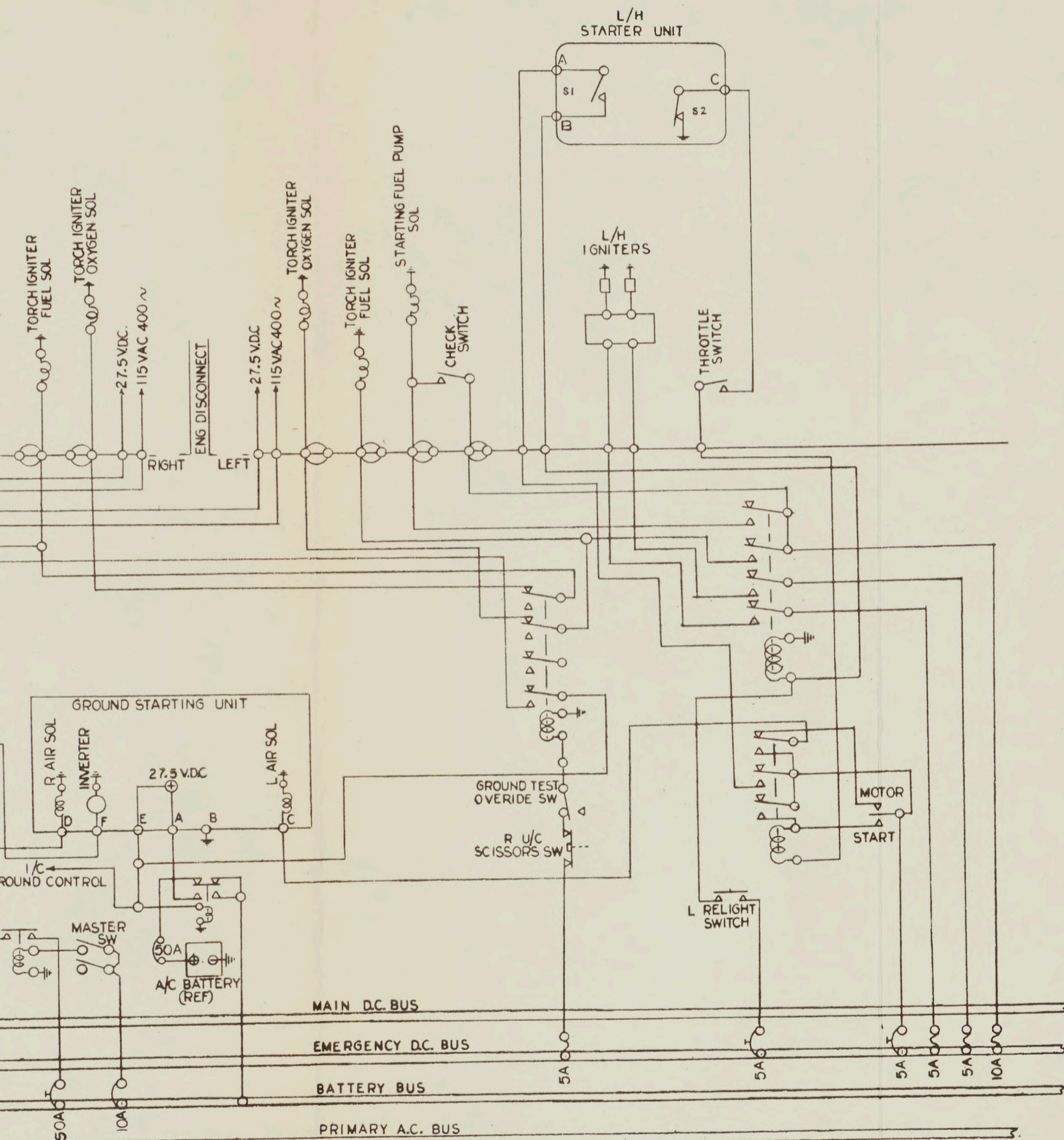
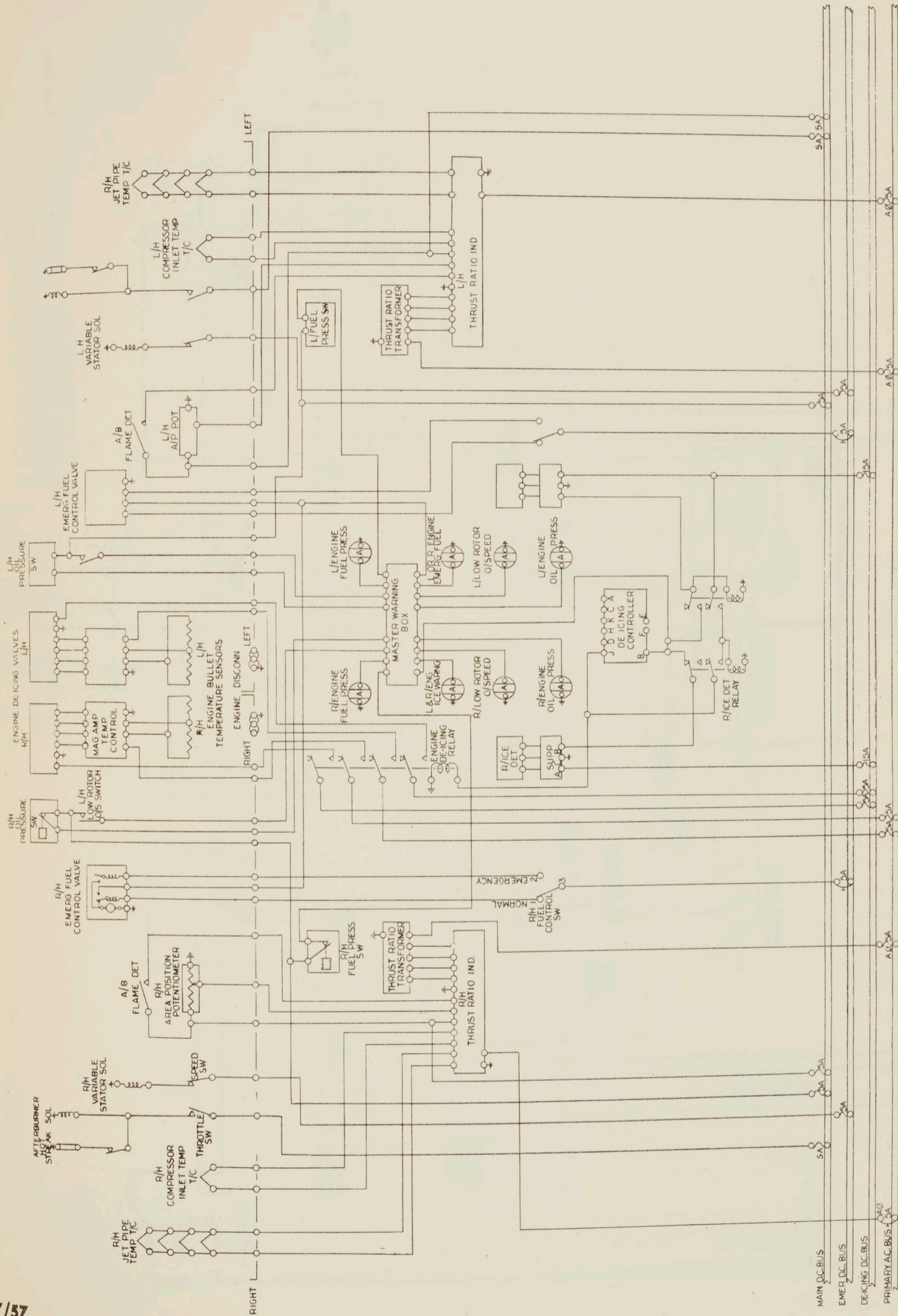

FIG. 2 STARTING AND IGNITION



MAY/57

FIG. 3 ENGINE SERVICES

/27

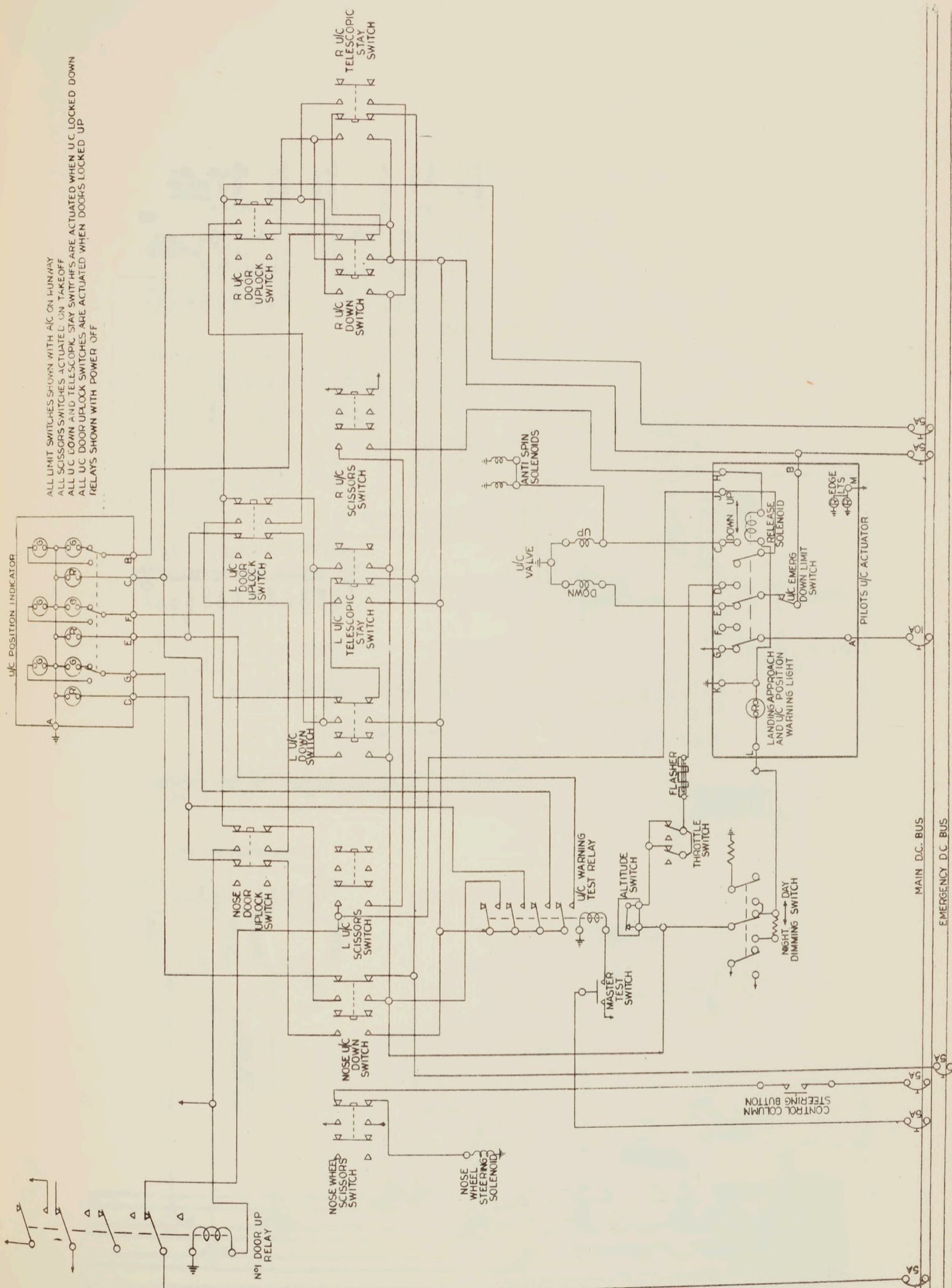

MAY/57

/27

FIG. 4 LANDING GEAR ACTUATION AND INDICATION

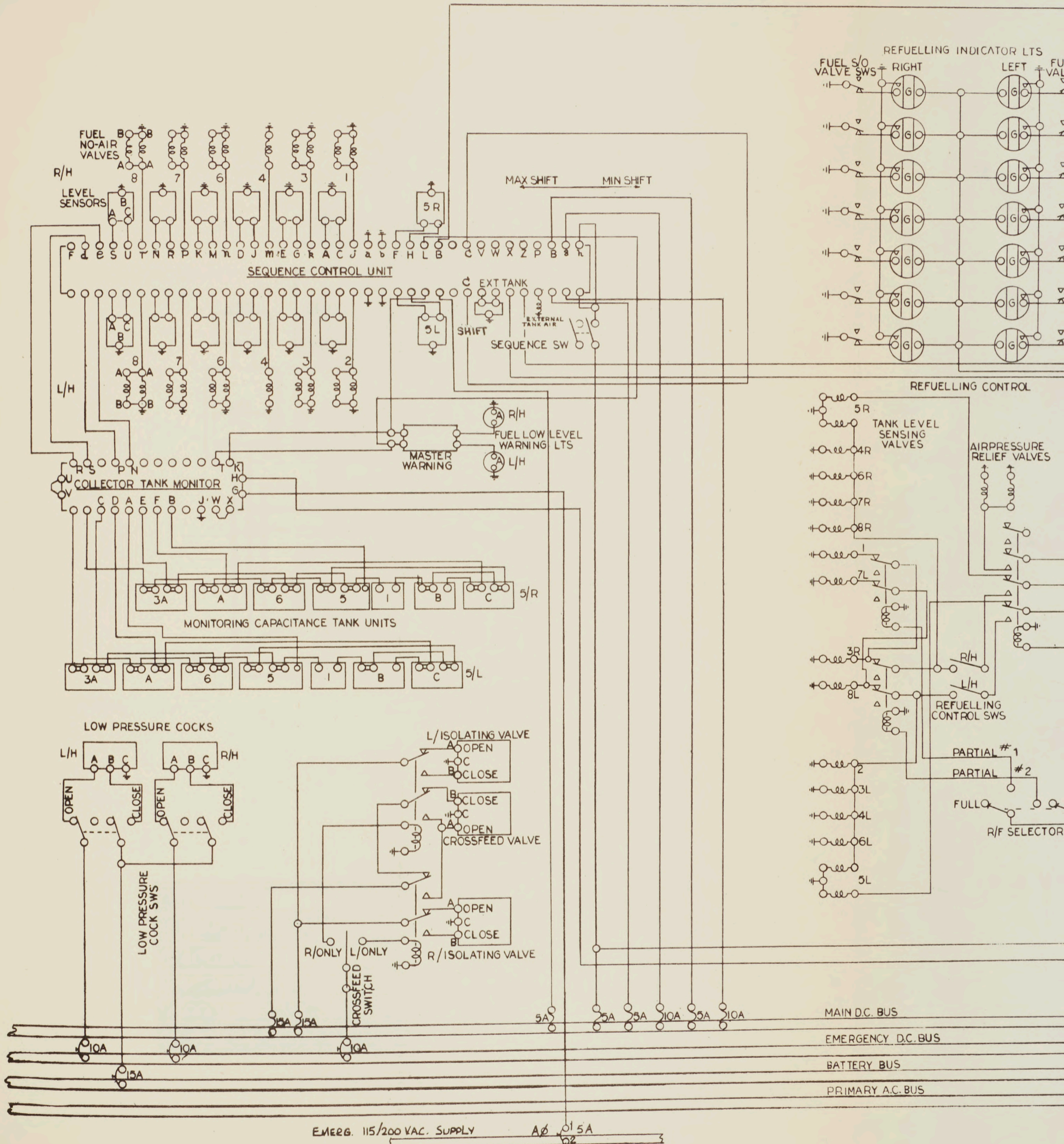
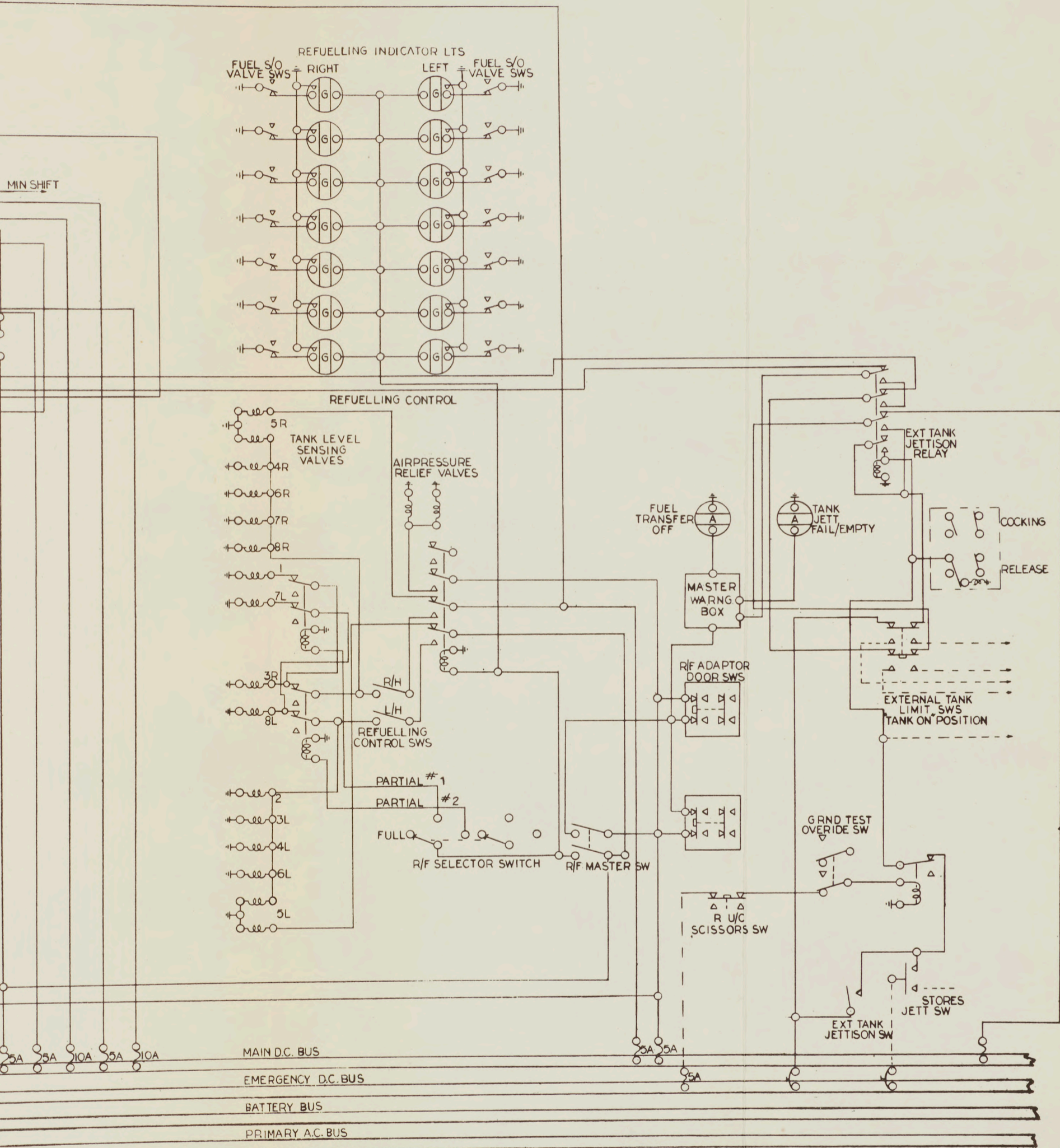

FIG. 5 FUEL CONTROL ELECTRICAL WIRING DIAGRAM



5 FUEL CONTROL ELECTRICAL WIRING DIAGRAM

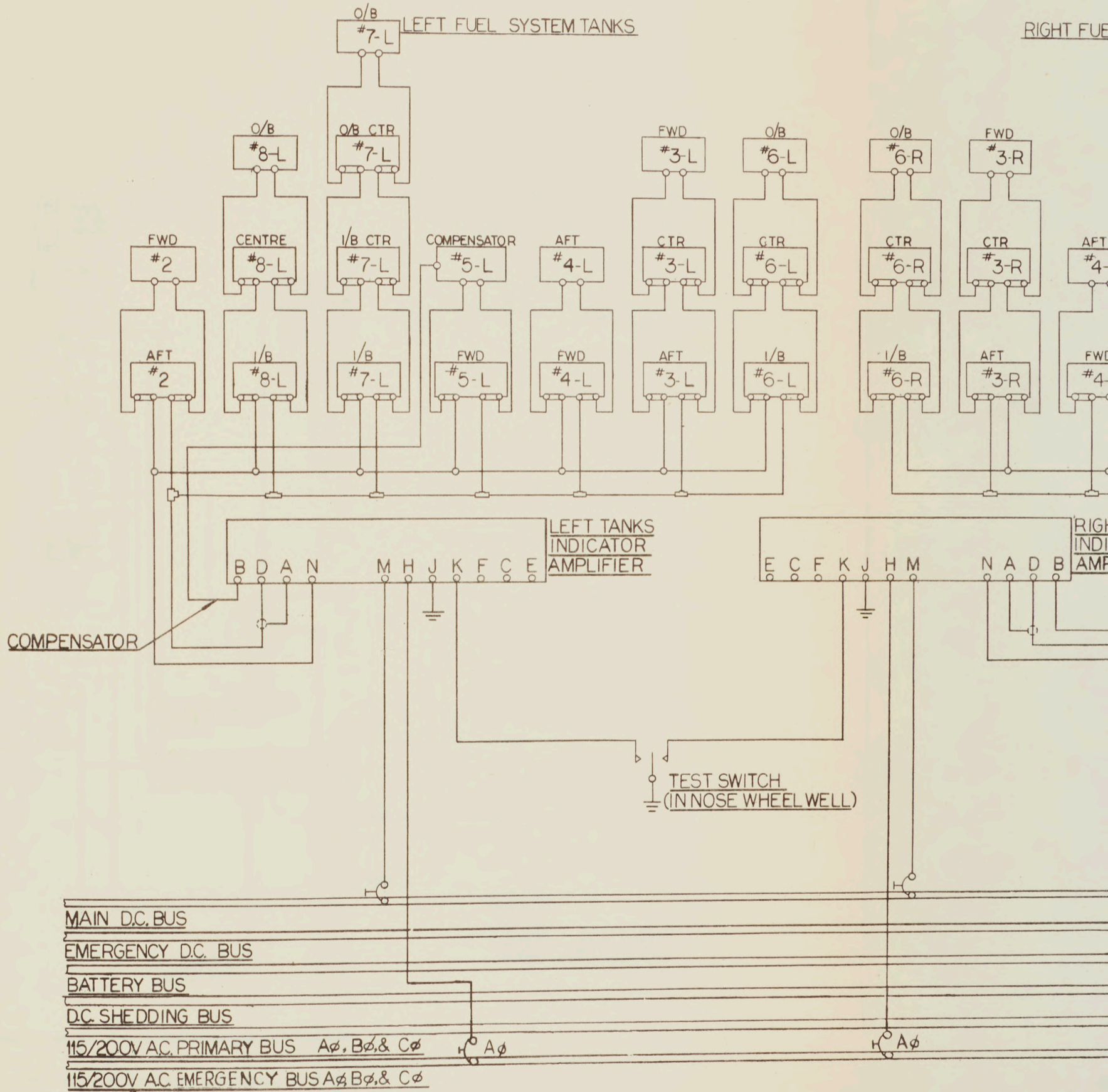

FIG. 6 FUEL CAPACITANCE INDICATION

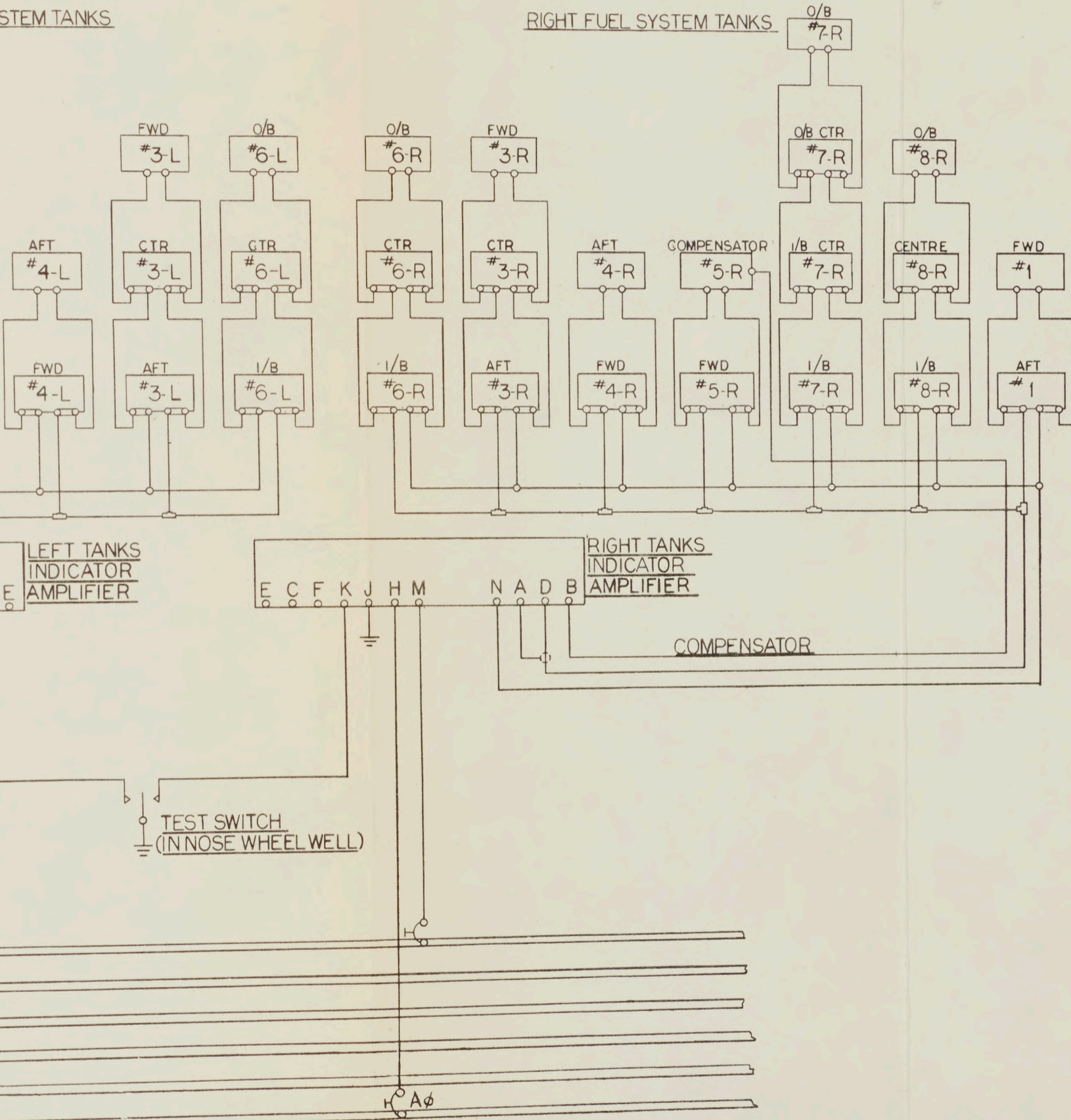

FIG. 6 FUEL CAPACITANCE INDICATION

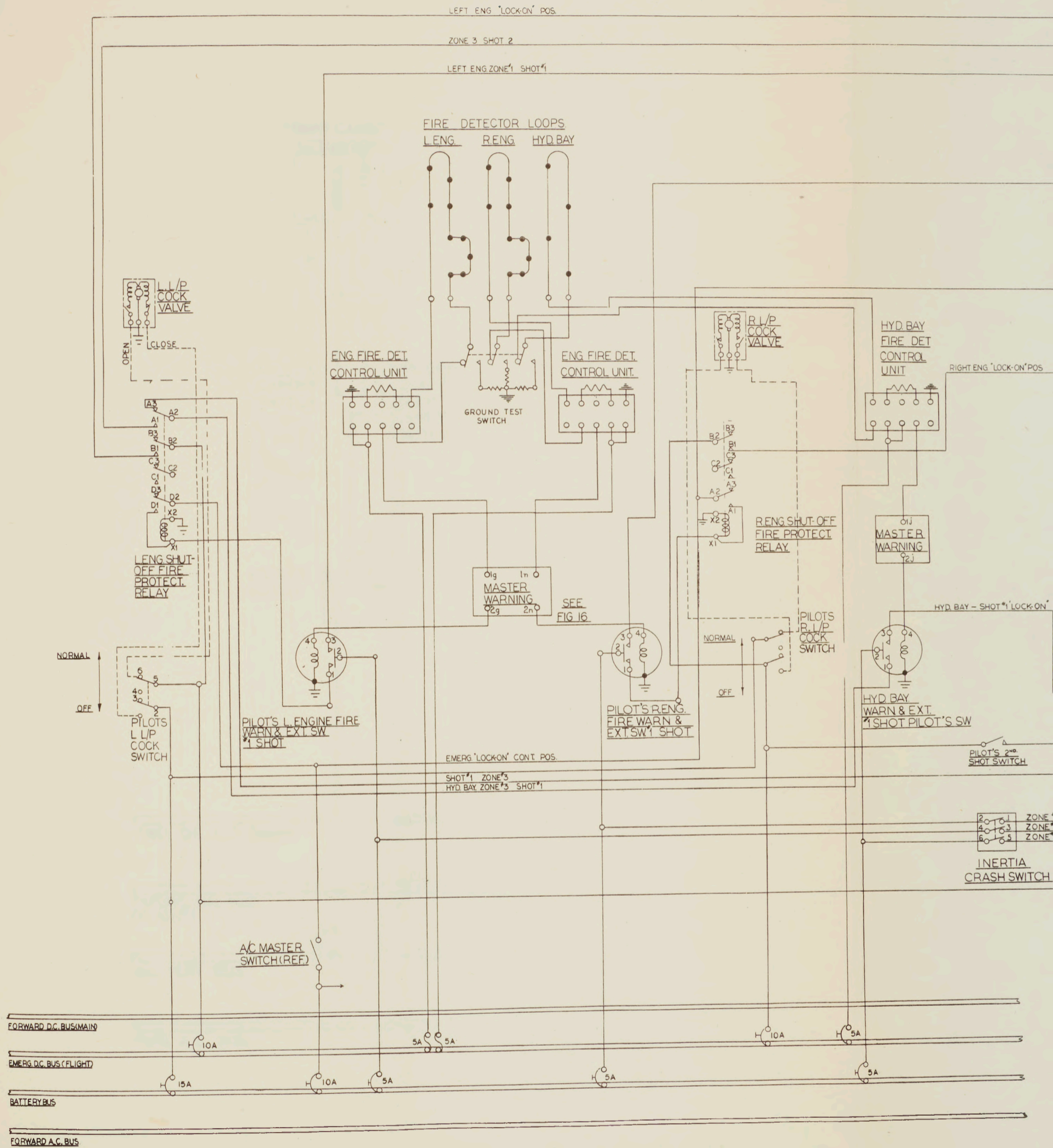

FIG. 7 FIRE PROTECTION SYSTEM

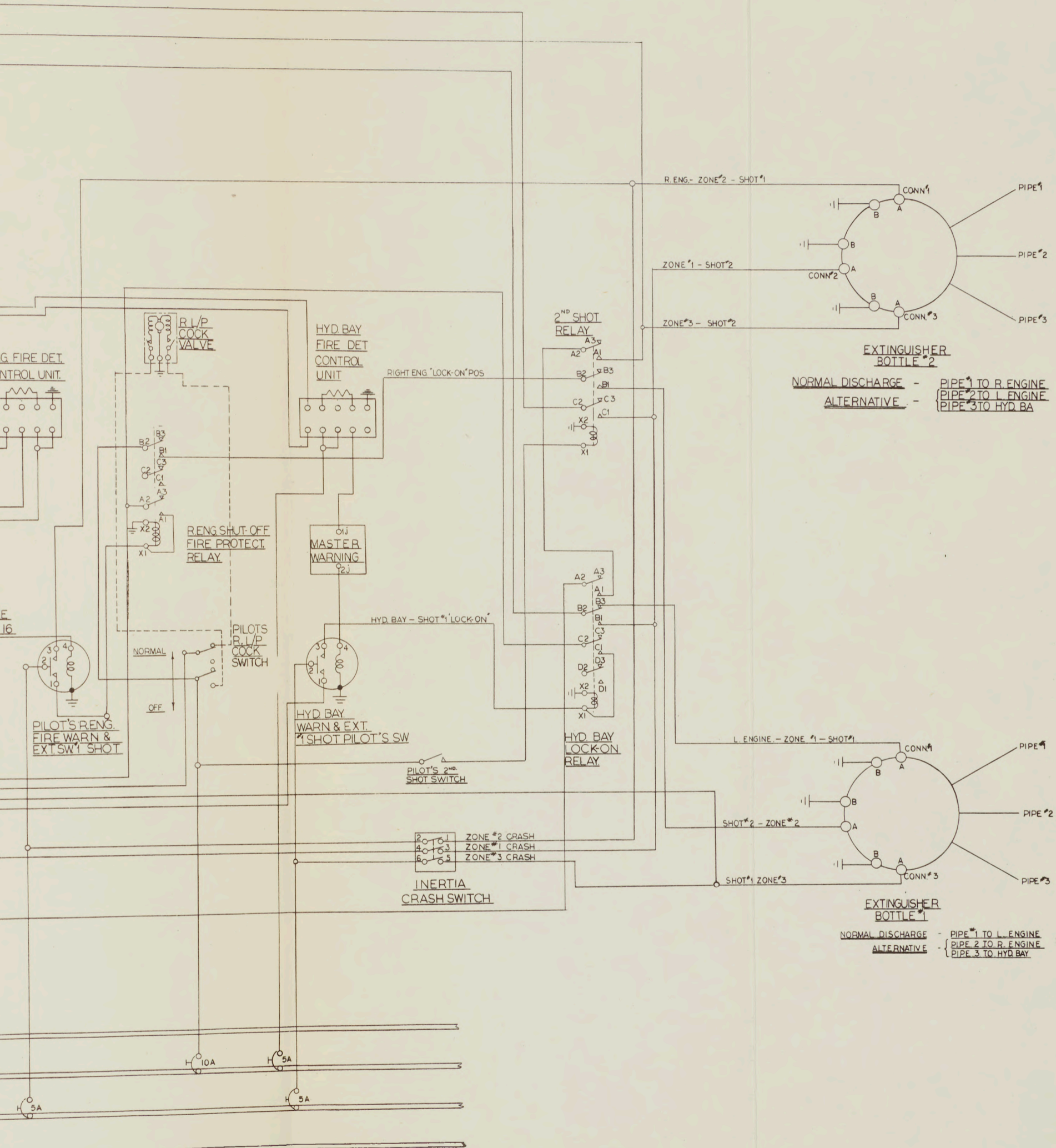

FIG. 7 FIRE PROTECTION SYSTEM

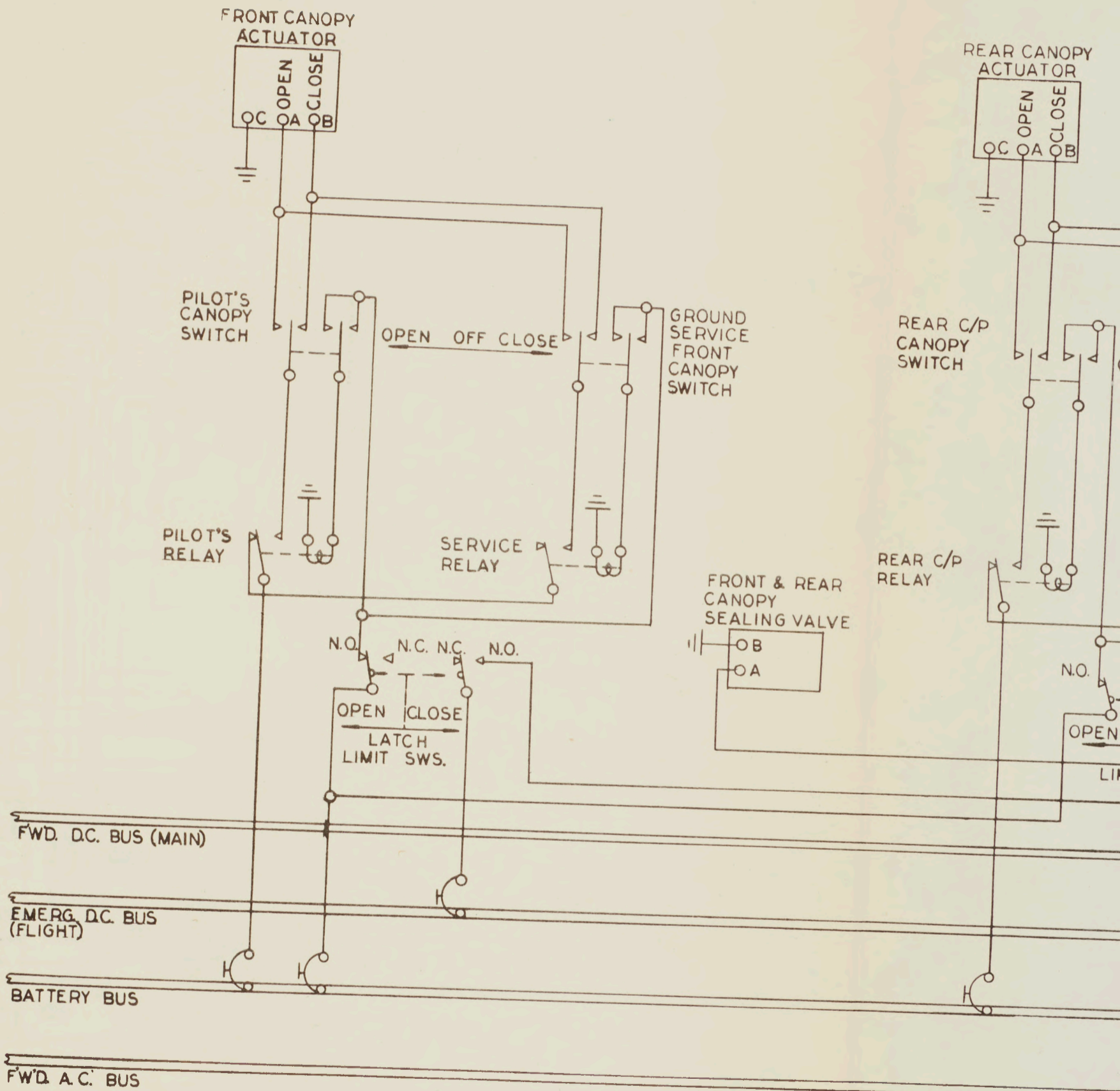

FIG. 8 CANOPY ACTUATION

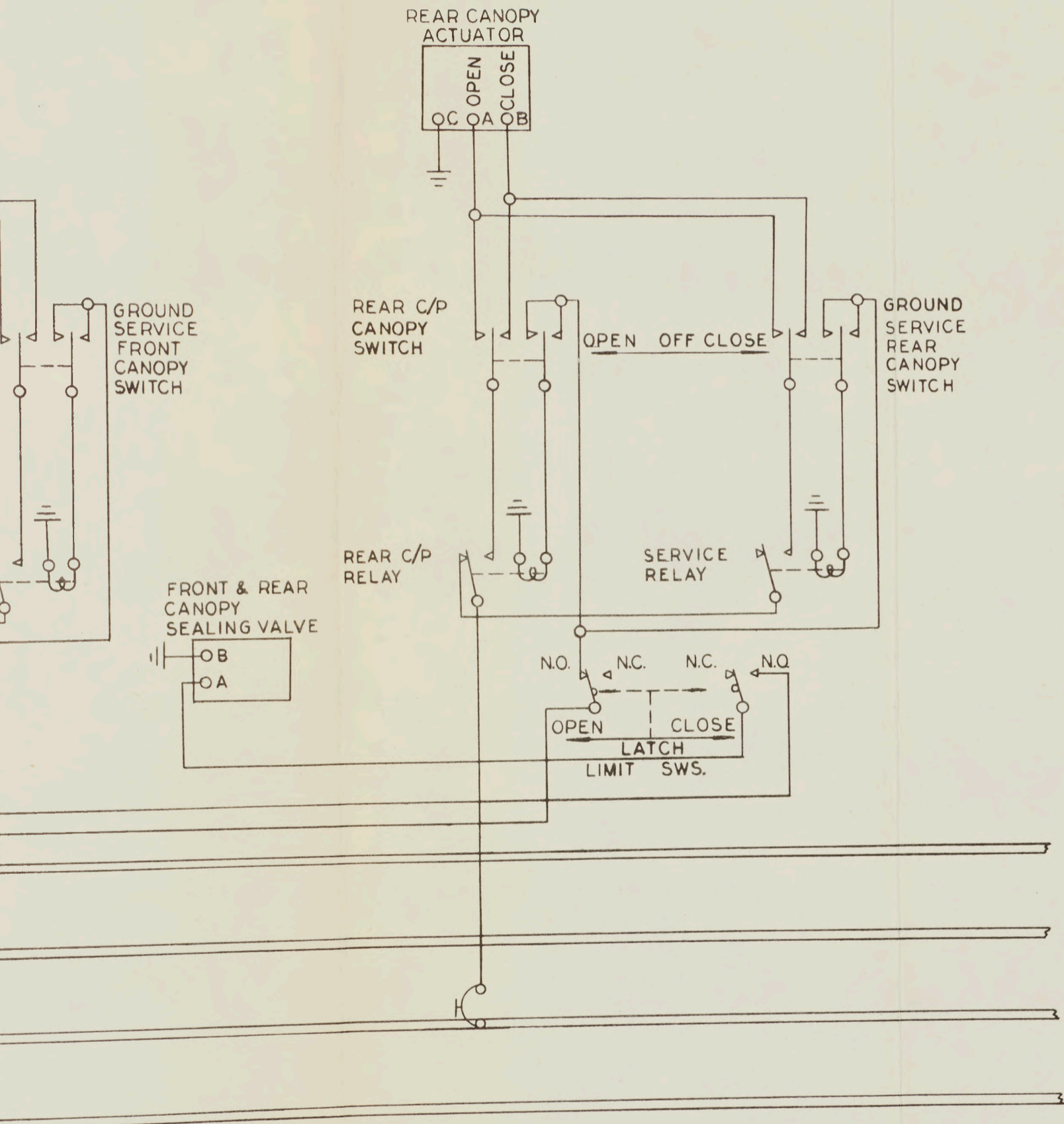

FIG. 8 CANOPY ACTUATION

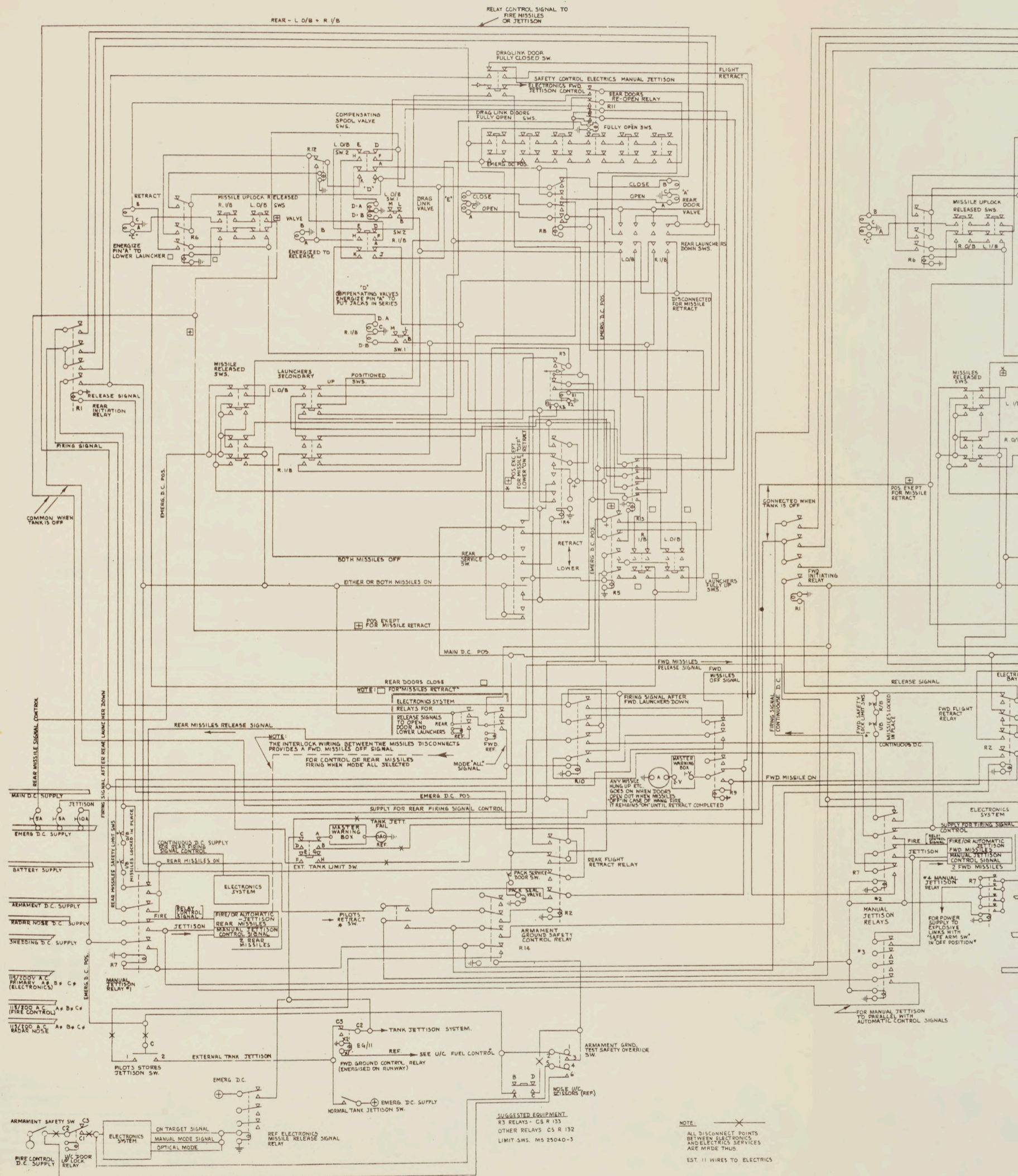
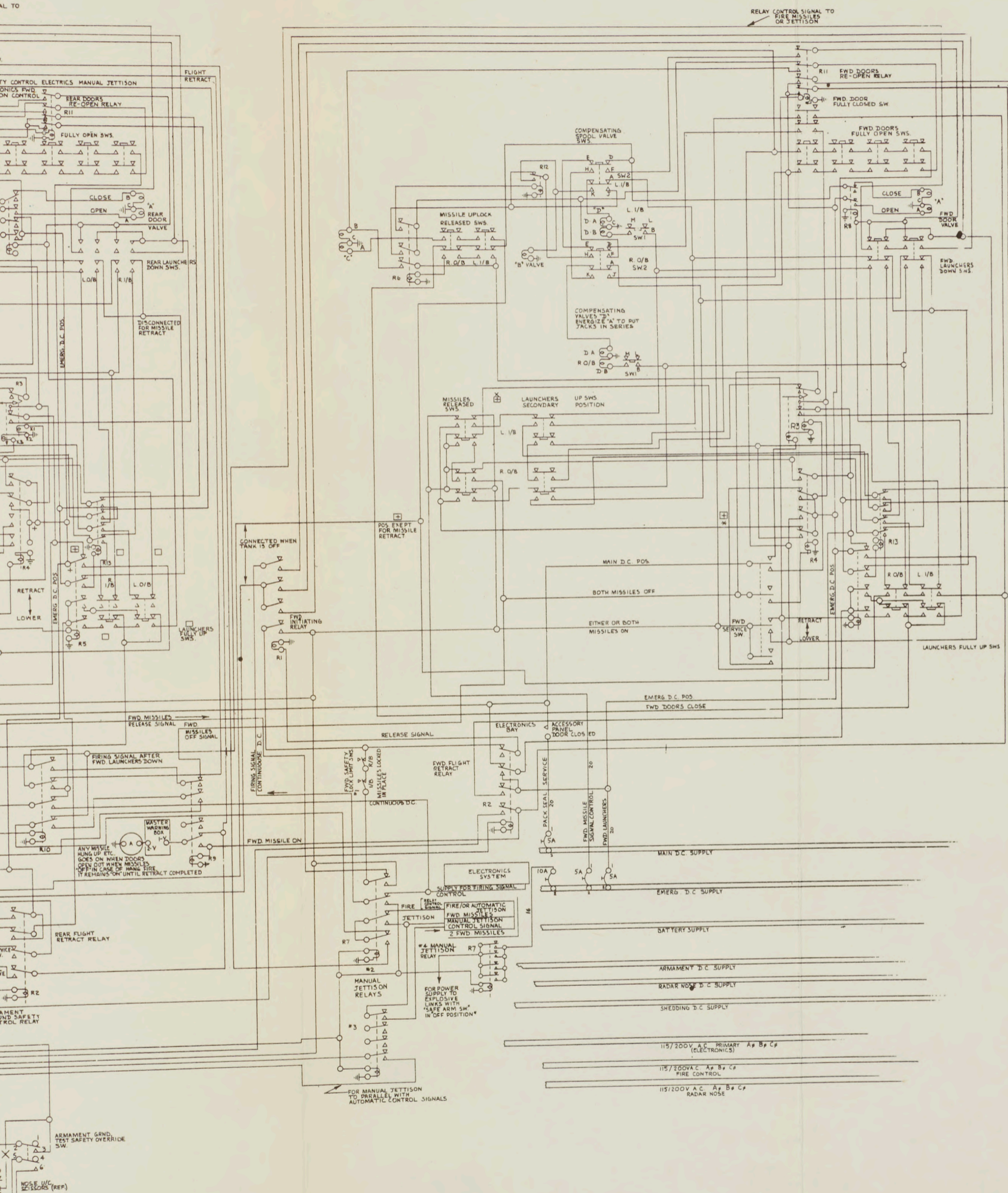
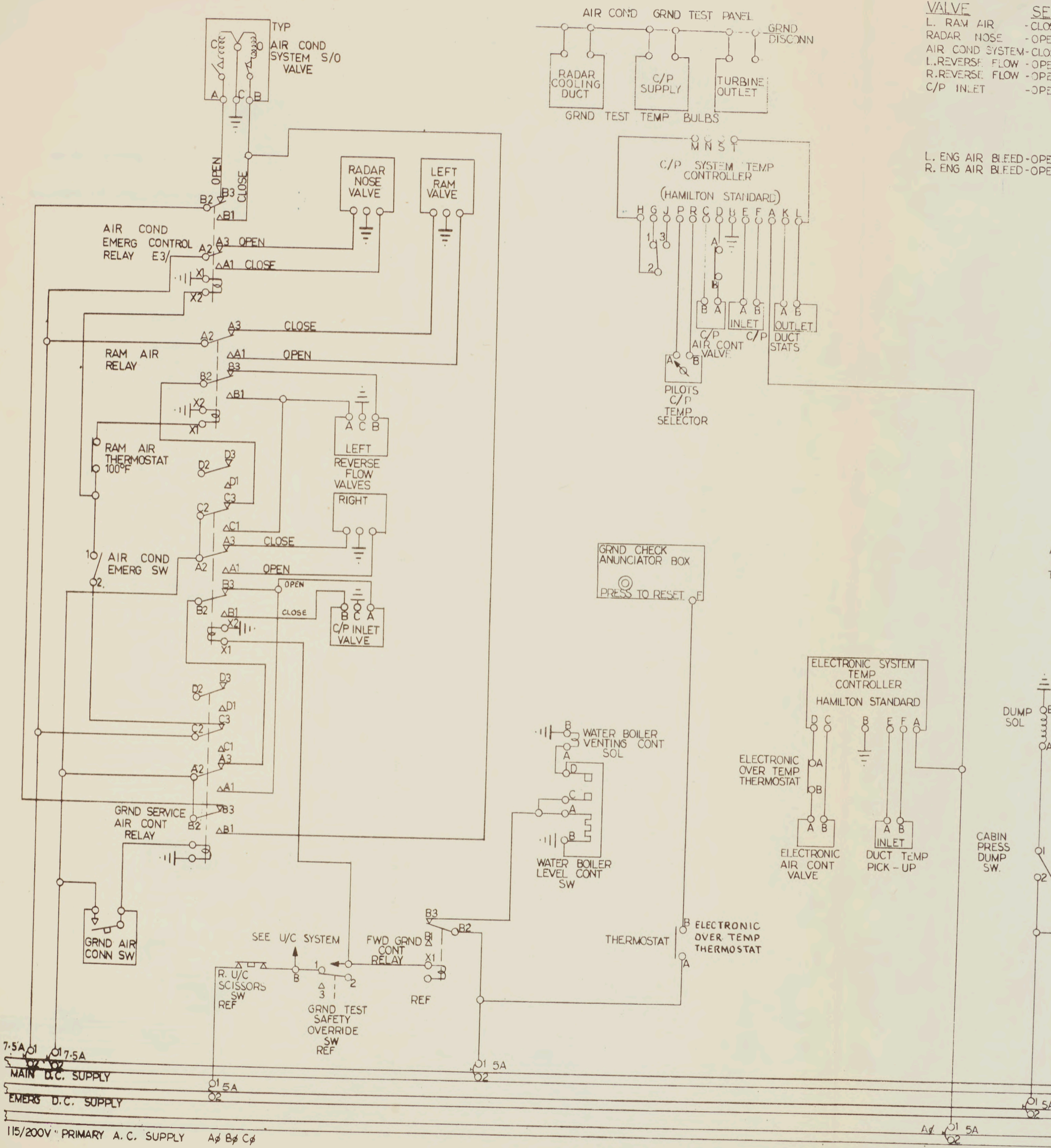

FIG. 9 SCHEMATIC - THEORETICAL CIRCUIT - CONTROL SYSTEM, MISSILE



THEORETICAL CIRCUIT - CONTROL SYSTEM, MISSILE HYDRAULICS



VALVE SEE
 L. RAM AIR -CLOSE
 RADAR NOSE -OPEN
 AIR COND SYSTEM-CLOSE
 L.REVERSE FLOW -OPEN
 R.REVERSE FLOW -OPEN
 C/P INLET -OPEN

L. ENG AIR BLEED-OPEN
 R. ENG AIR BLEED-OPEN

MAY/57

115/200V PRIMARY A.C. SUPPLY Aφ Bφ Cφ

FIG. 10 AIR CONDITIONING

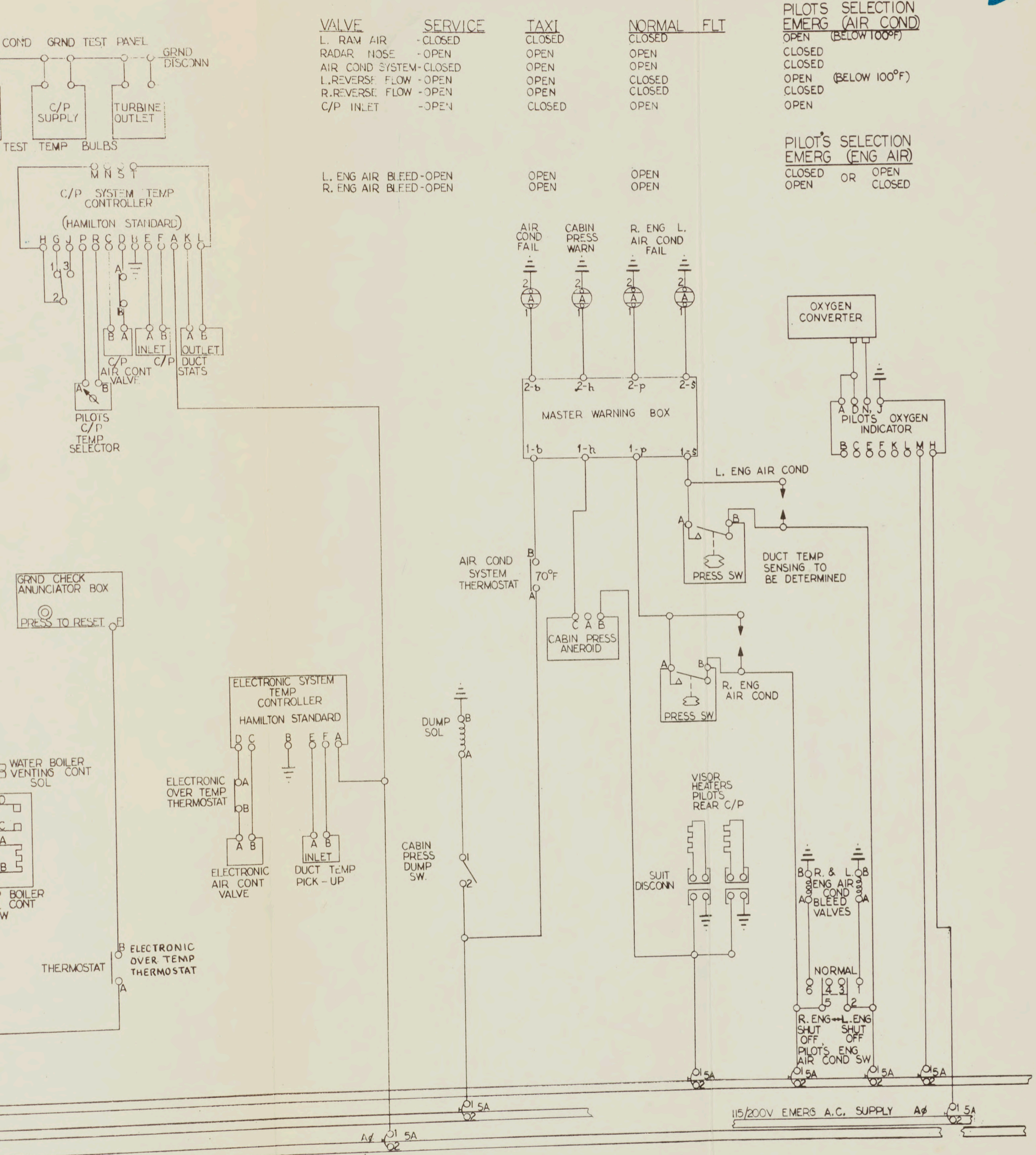

VALVE	SERVICE	TAXI	NORMAL	FLT	PILOTS SELECTION EMERG (AIR COND)	PILOTS SELECTION EMERG (ENG AIR)
L. RAM AIR	- CLOSED	CLOSED	CLOSED	CLOSED	OPEN (BELOW 100°F)	CLOSED OR OPEN
RADAR NOSE	- OPEN	OPEN	OPEN	OPEN	CLOSED	OPEN OR CLOSED
AIR COND SYSTEM	- CLOSED	OPEN	OPEN	OPEN	CLOSED	
L. REVERSE FLOW	- OPEN	OPEN	CLOSED	CLOSED	OPEN (BELOW 100°F)	
R. REVERSE FLOW	- OPEN	OPEN	CLOSED	CLOSED	CLOSED	
C/P INLET	- OPEN	CLOSED	OPEN	OPEN	OPEN	
L. ENG AIR BLEED	- OPEN	OPEN	OPEN	OPEN		
R. ENG AIR BLEED	- OPEN	OPEN	OPEN	OPEN		

FIG. 10 AIR CONDITIONING

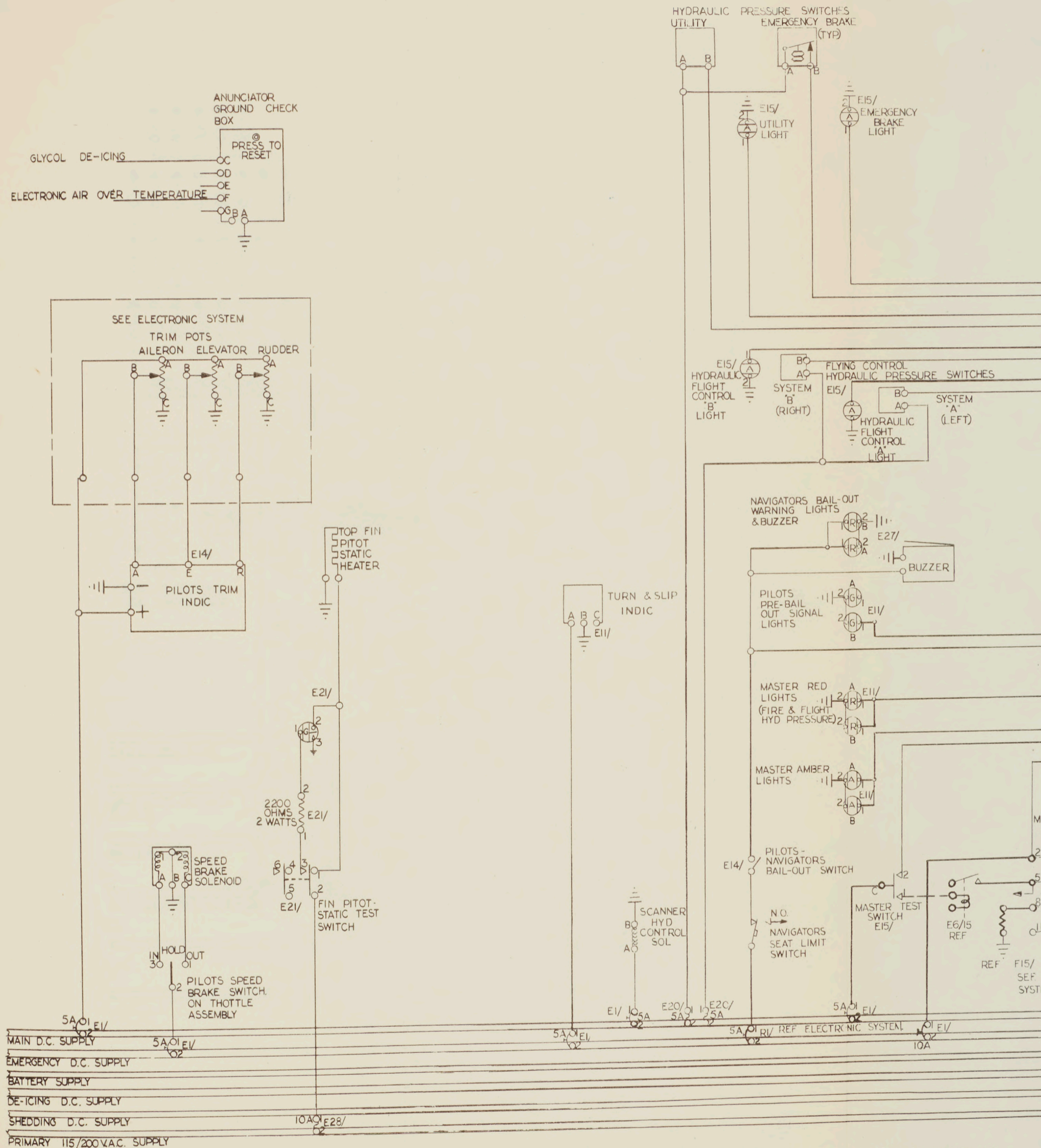

FIG. 11 FLIGHT SERVICES & MASTER WARNING

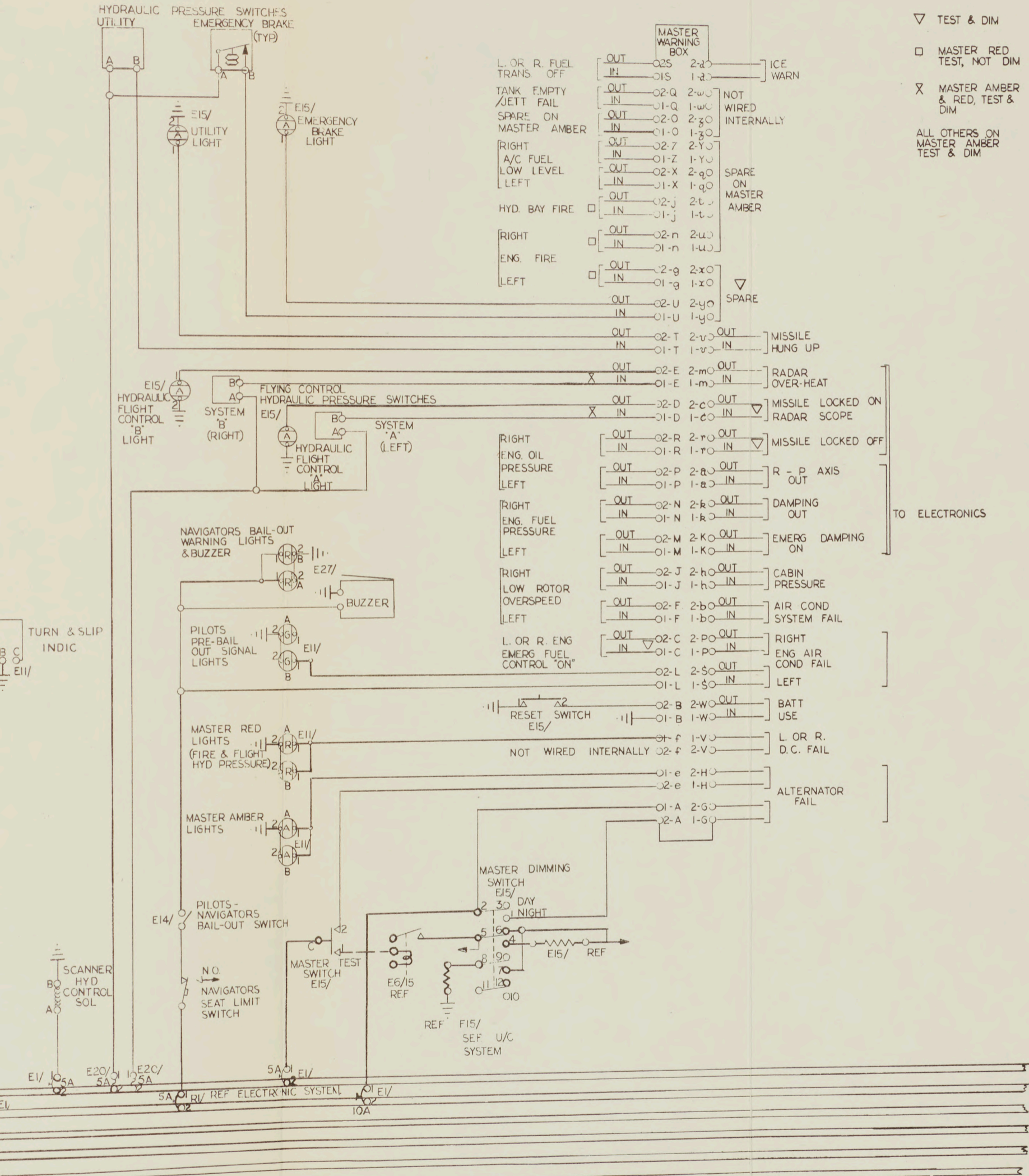

FIG. 11 FLIGHT SERVICES & MASTER WARNING

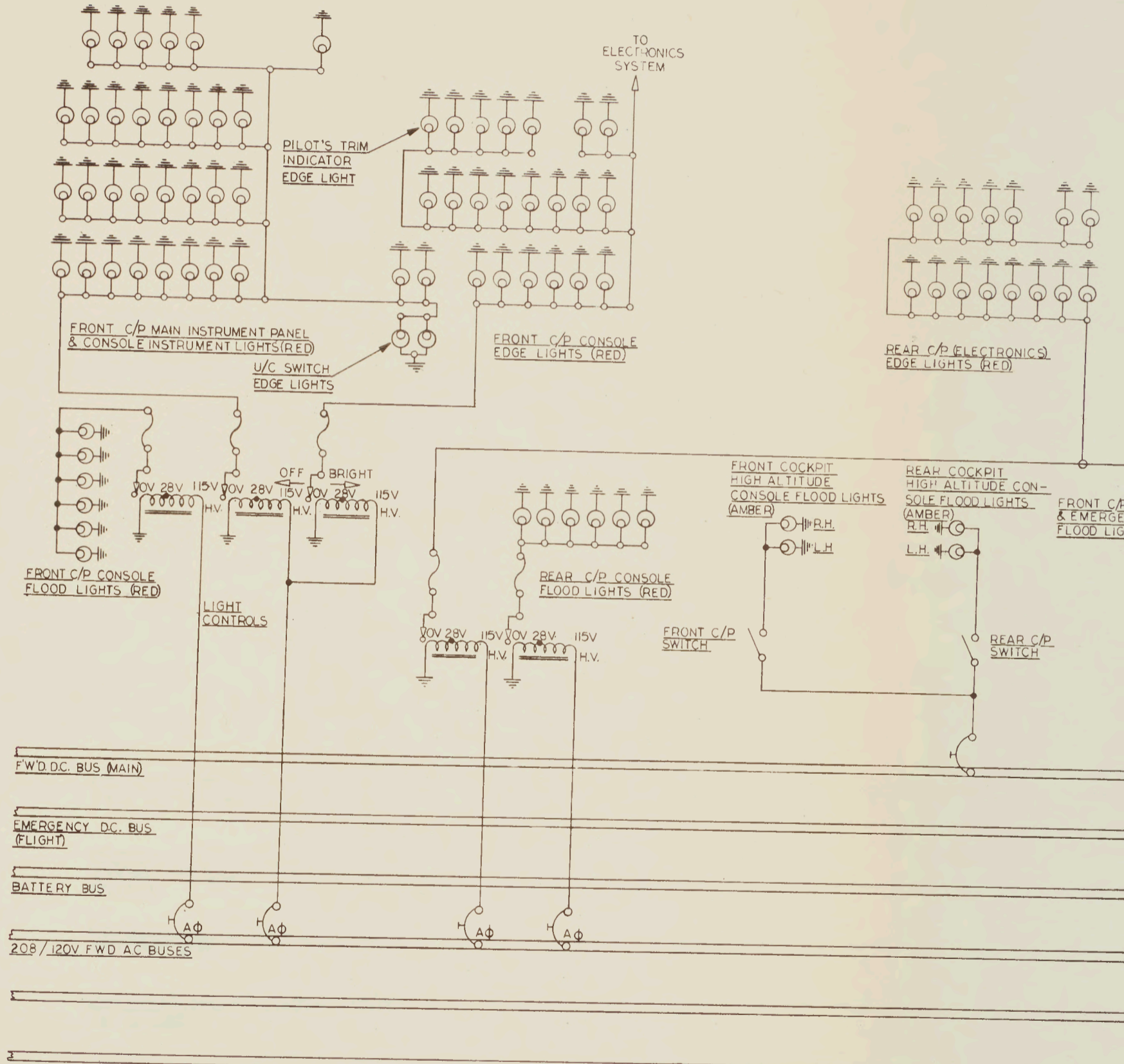

FIG. 12 COCKPIT LIGHTS

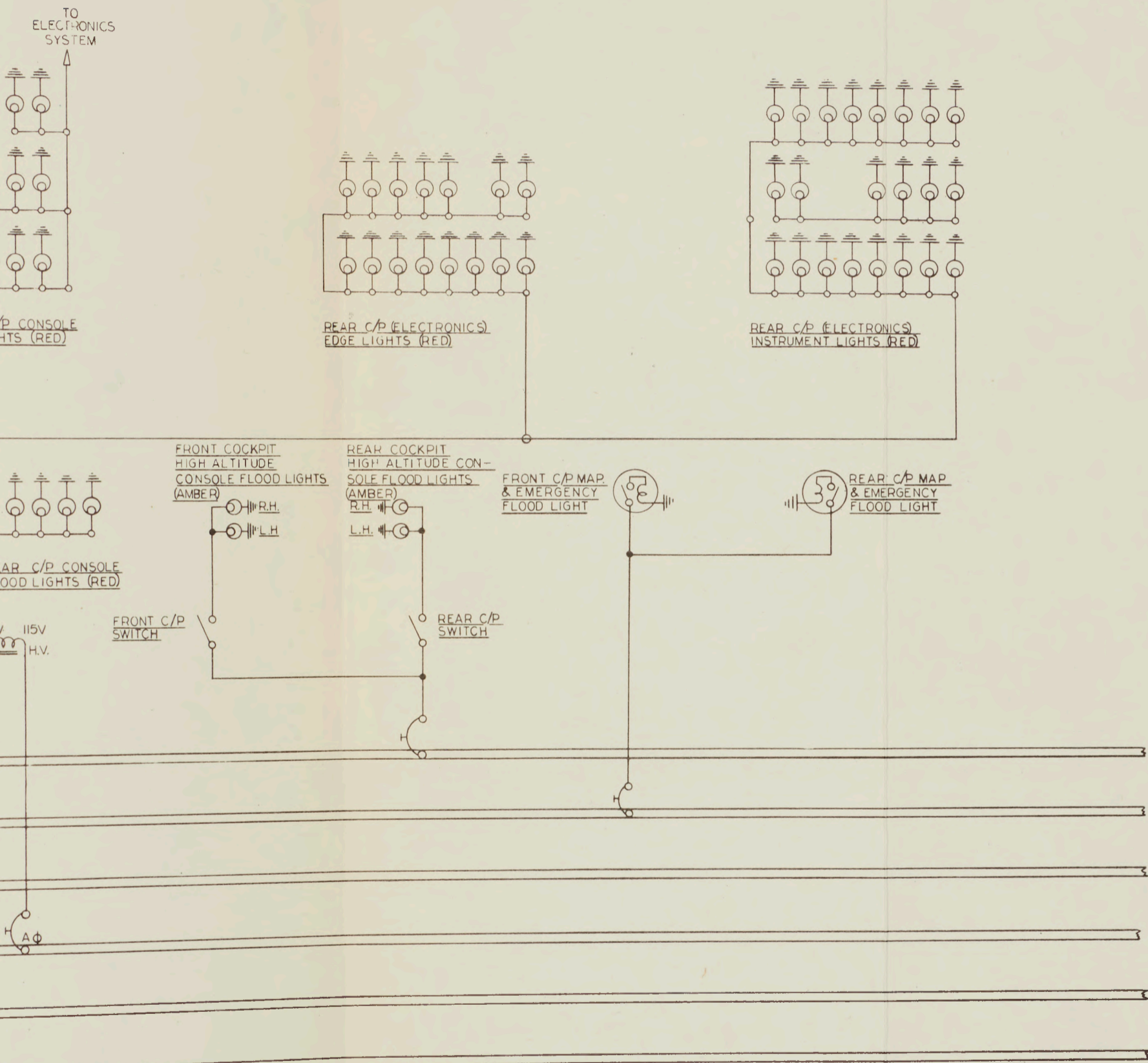

FIG. 12 COCKPIT LIGHTS

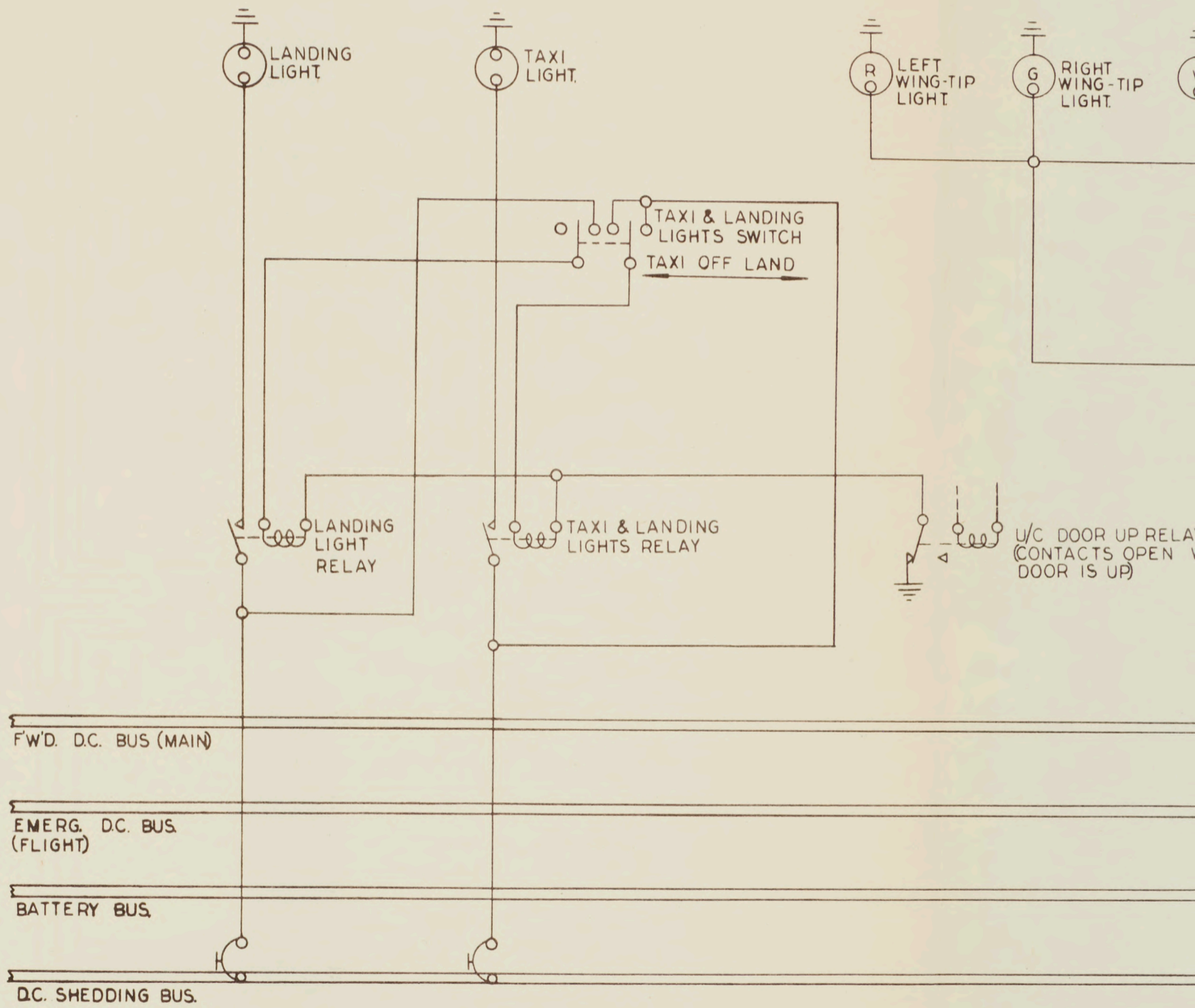

FIG. 13 EXTERNAL LIGHTS

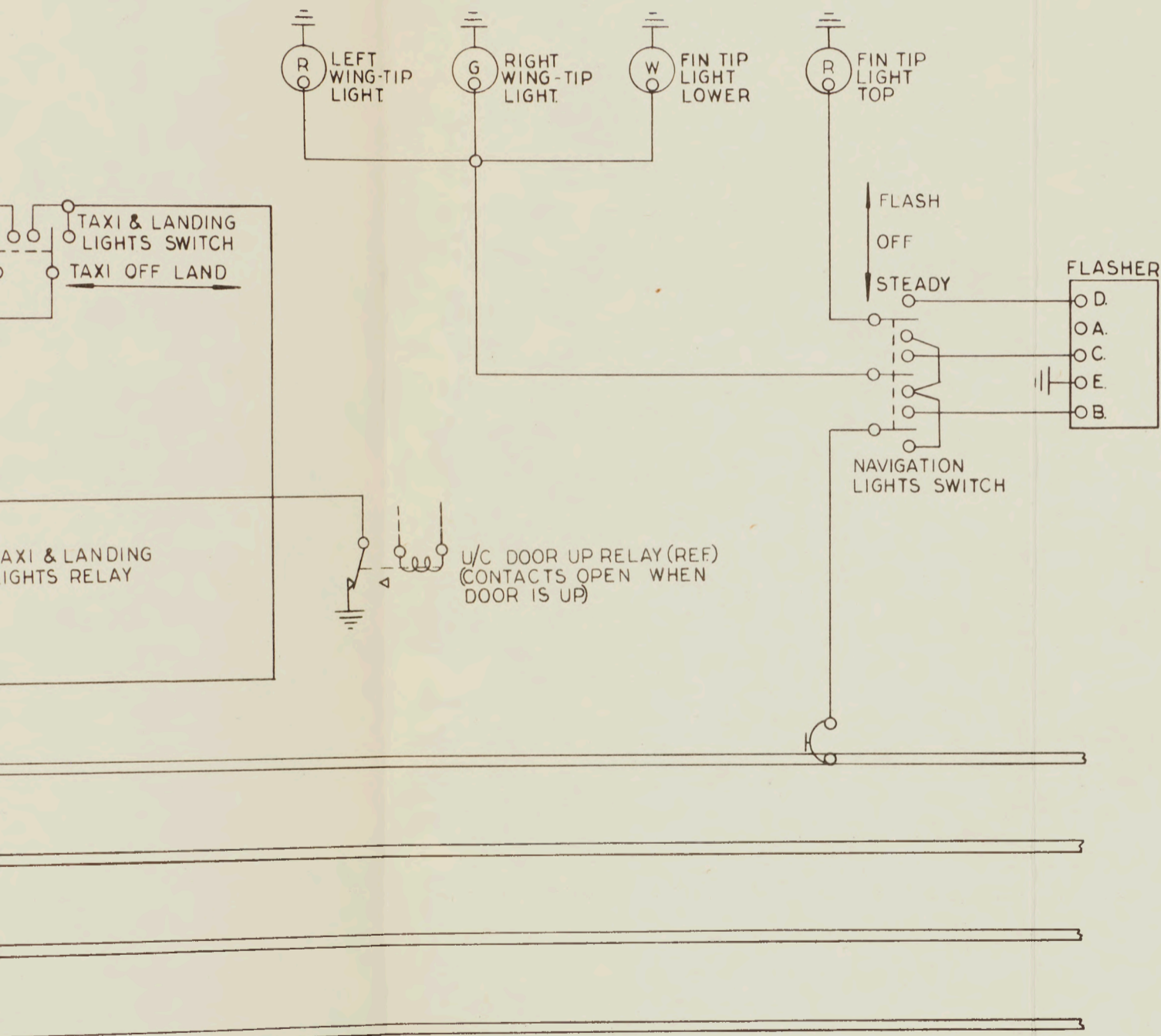
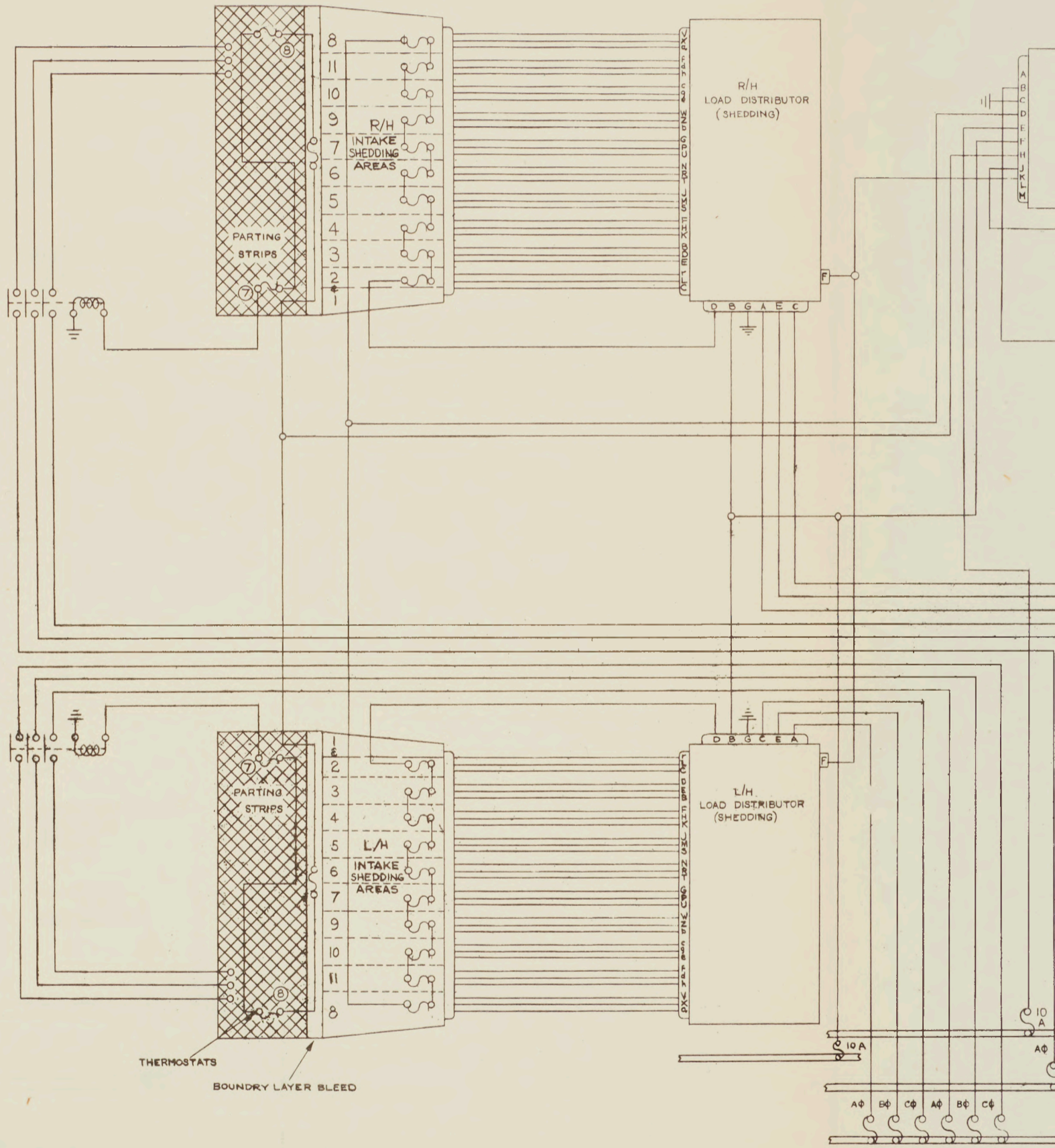

FIG. 13 EXTERNAL LIGHTS



MAY/57

FIG. 14 INTAKE RAMP DE-ICING

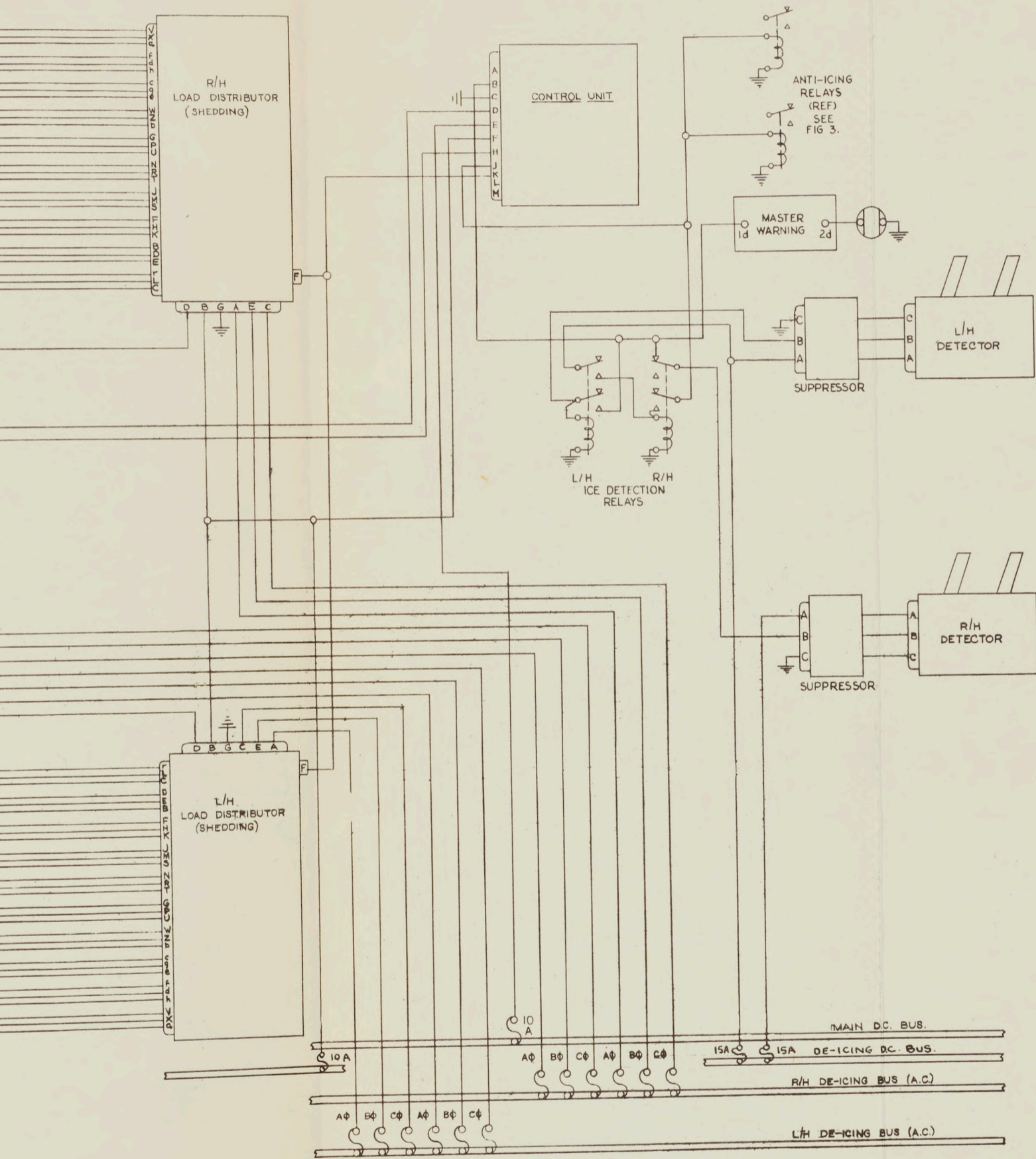
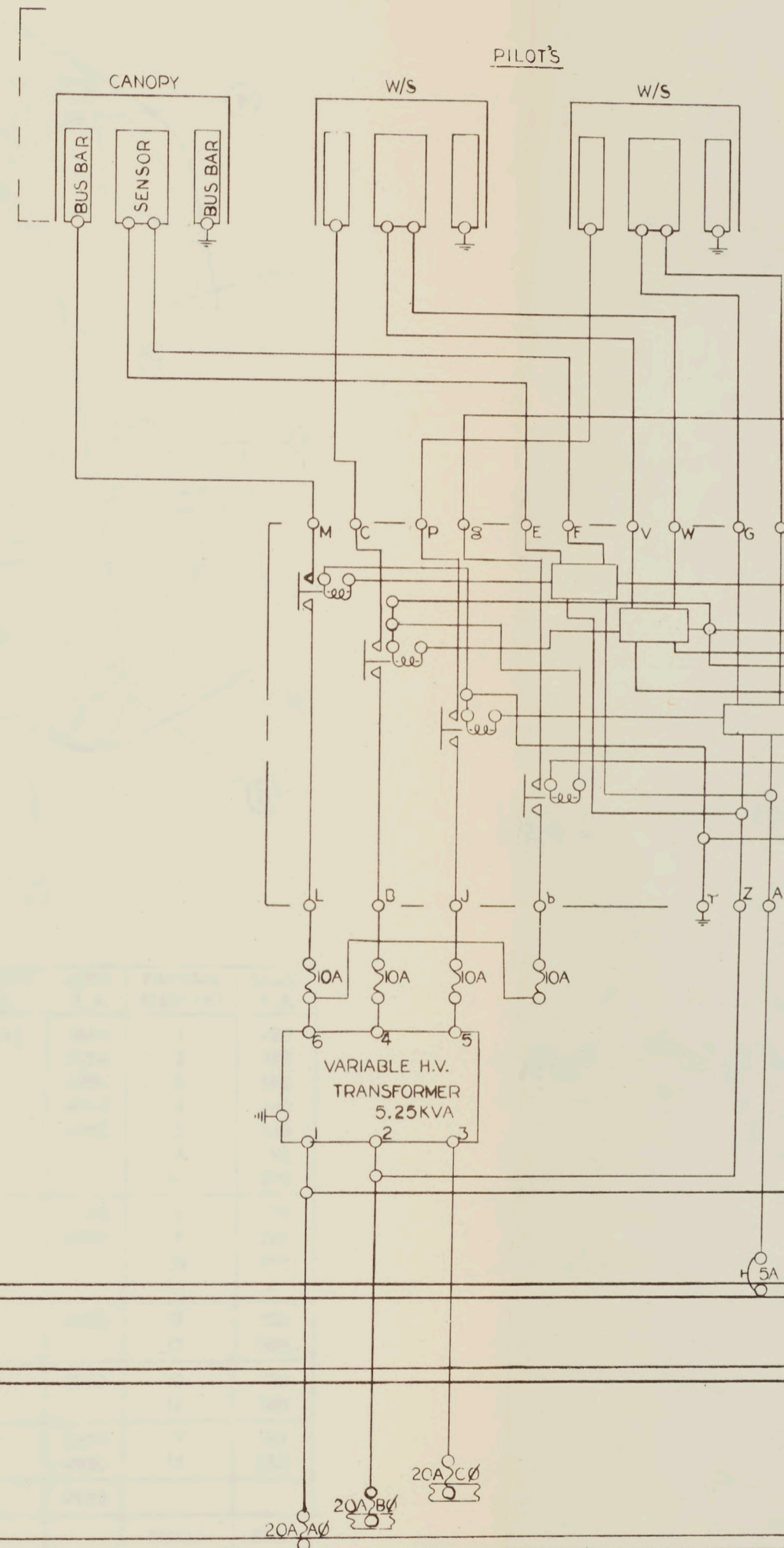
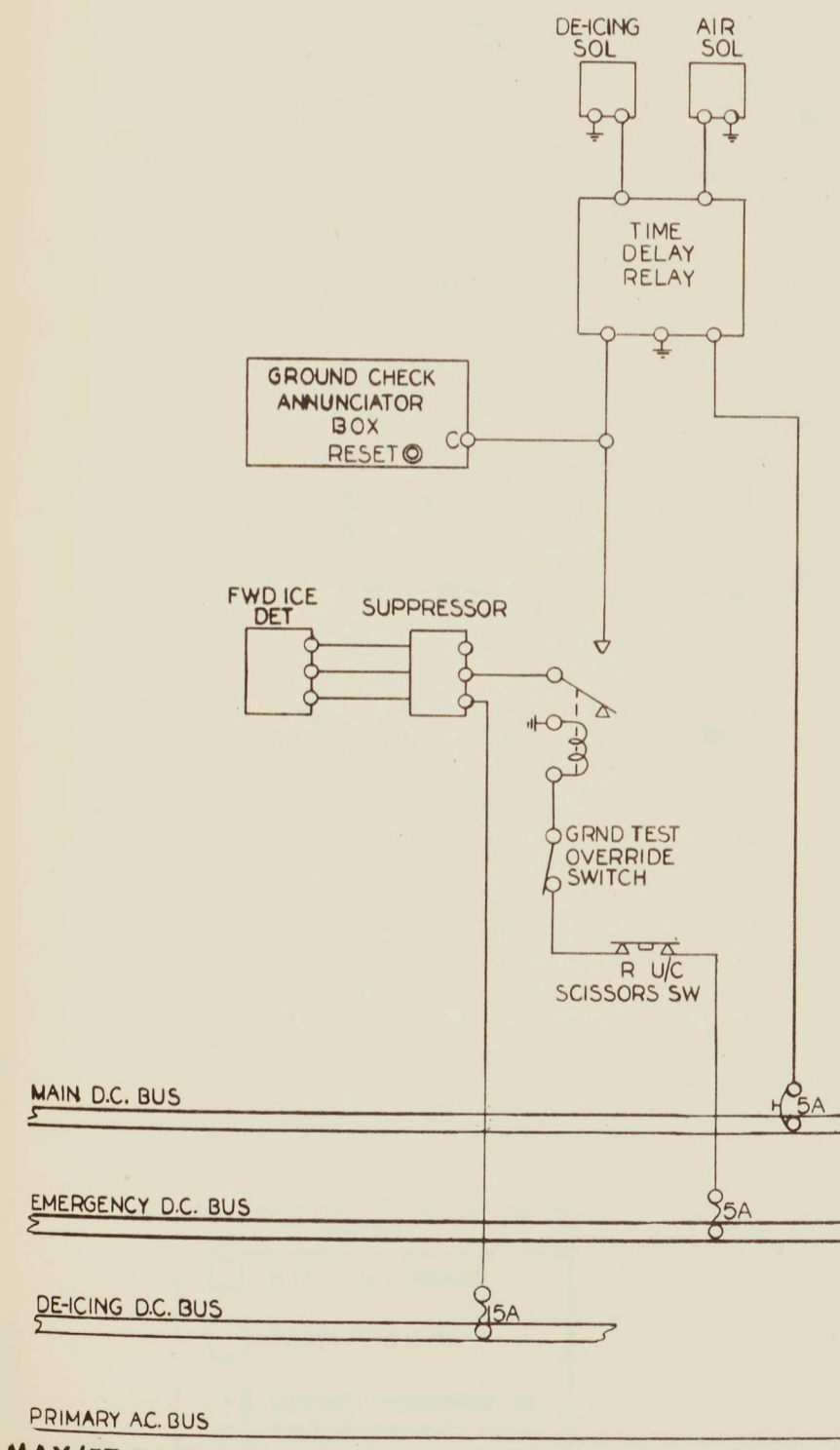

FIG. 14 INTAKE RAMP DE-ICING

RADOME DE-ICING



PRIMARY AC. BUS

MAY/57

FIG. 15 RADOME-WINDSCREEN AND CANOPY DE-ICING

W/S & CANOPY DE-ICING

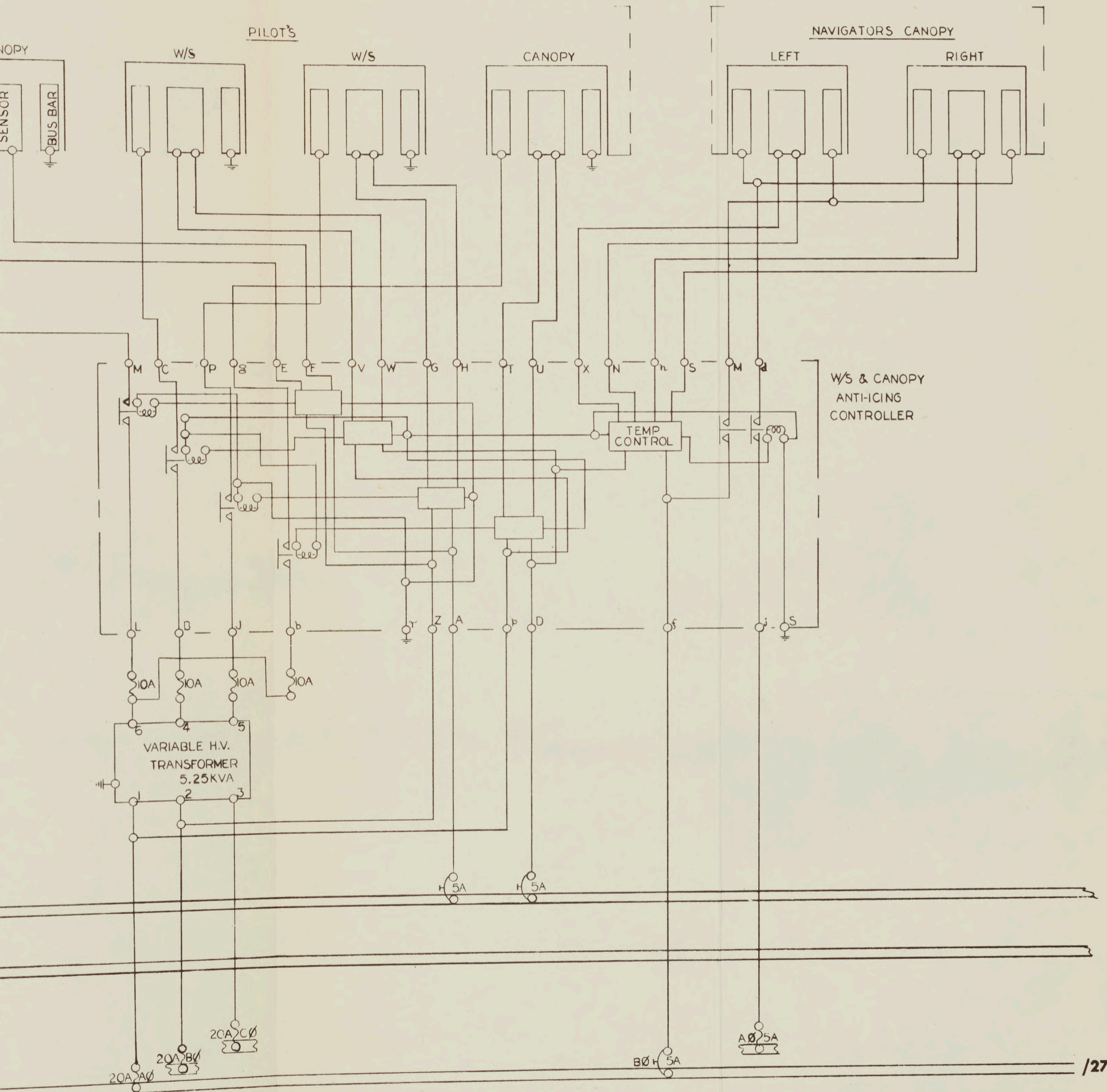
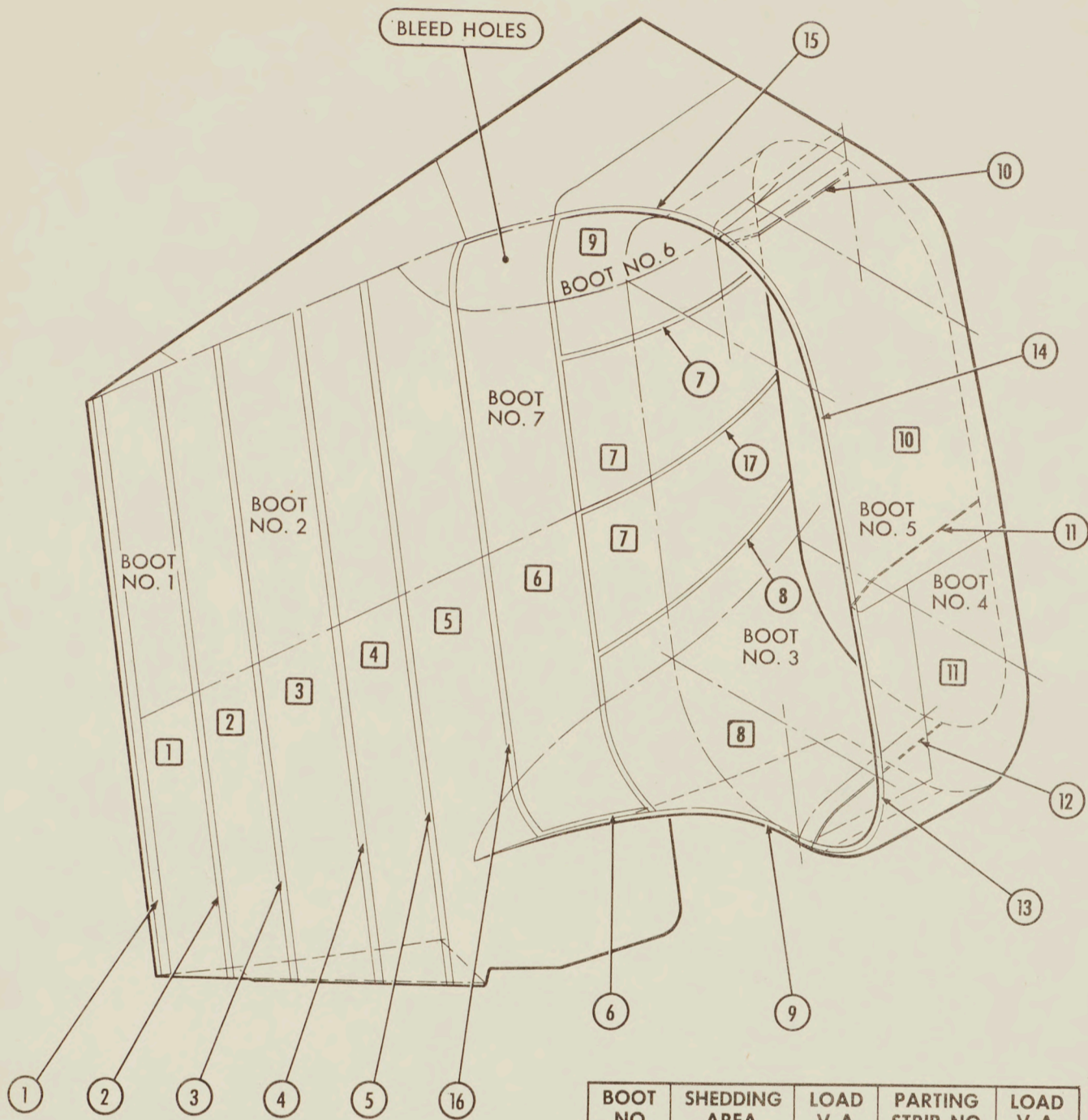

FIG. 15 RADOME-WINDSCREEN AND CANOPY DE-ICING



BOOT NO.	SHEDDING AREA	LOAD V. A.	PARTING STRIP NO.	LOAD V. A.
1	1*	1670	1	480
2	2 }	3280	2	122
	3	4950	3	388
	4	4950	4	140
	5	4950	5	148
			6	95
			16	375
3	7+	2550	8	123
	8	4950	9	232
			12	100
			17	47
4	11	4950	11	100
			13	300
5	10	4950	10	100
			14	300
6	7+	2400	7	123
	9	4950	15	232
7	6	4950		
			TOTAL	8355

LEGEND	
□	SHEDDING AREAS
○	PARTING STRIPS
+ }	CYCLED TOGETHER AS
* }	ONE SHEDDING AREA

MAY/57

FIG. 16 DUCT DE-ICING

/27

