

QC  
Avro  
CF105  
AIREQ-25-1

JUNE 1957

SECRET

**ARROW 2  
ENGINE INSTALLATION**

REPORT No. AIREQ 25/1

ENGINEERING DIVISION



*AVRO AIRCRAFT LIMITED*

**UNCLASSIFIED**

SECURITY WARNING

This document is classified "SECRET" and is intended solely for the use of the recipient and such persons as have been delegated to use it in the course of their duty and may only be used in connection with work performed for or on behalf of Her Majesty's Canadian Government.

The unauthorized retention or destruction of this document or disclosure of its contents to any unauthorized person is forbidden.

Failure to comply with any of the above instructions is an infraction of the Official Secrets Act.

Any unauthorized person obtaining possession of this document, by finding or otherwise, must forward it, together with his name and address, in a registered envelope, to the Engineering Division, AVRO Aircraft Ltd., Malton, Ontario, Canada.

This is copy number ..... **51** .....  
Issued to .....  
Date .....

Classification cancelled/changed to .....  
by authority of ..... (date) .....  
Signature .....  
*[Handwritten signature]*

NRC - CISTI  
AÉRO / M.E.  
LIBRARY  
  
89- 05- 12  
  
BIBLIOTHÈQUE  
AÉRO / G.M.  
CNRC - ICIST

UNCLASSIFIED

## ARROW 2 ENGINE INSTALLATION

REPORT NO. 72/AIREQ 25/1

JUNE 1957

This brochure is intended to provide an accurate description of the system(s) or service(s) for purposes of the Arrow 2 Mock-up Conference, and is not to be considered binding with respect to changes which may occur subsequent to the date of publication.

COMPILED BY

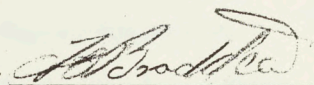

APPROVED BY

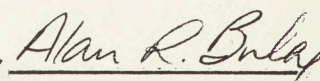

ENGINEERING DIVISION

**AVRO AIRCRAFT LIMITED**

MALTON — ONTARIO

UNCLASSIFIED

## TABLE OF CONTENTS

SECTION	TITLE	PAGE
1.	Introduction	1
2.	General Description of the Iroquois Engine	5
3.	Method of Engine Attachment and Suspension	10
4.	Air Intake and Ventilating System	15
5.	Accessories Drive and Gearbox Installation and Lubrication System	20
6.	Engine Starting System	28
7.	Engine Power Control System	34

## LIST OF ILLUSTRATIONS

FIGURE	TITLE	PAGE
1.	Major Dimensions Orenda Iroquois Series 2 Engine	4
2.	Engine Suspension	9
3.	Engine Cooling - Static	13
4.	Engine Cooling - Flight	14
5.	Accessories Gearbox	26
6.	Engine Driven Accessories Drive Installation	27
7.	Engine Controls - Schematic	32
8.	Control Cable Tension Regulator	33



UNCLASSIFIED

## 1.0 INTRODUCTION

The Arrow 2 power plant installation and its associated systems have been designed for simplicity of handling, servicing and accessibility, consistent with performance requirements and minimum weight.

The basic installation concept of the Pratt and Whitney J75 engine in the Arrow 1, has been followed in the design of the Orenda Iroquois in the Arrow 2, though numerous detail changes have been necessary.

RCAF specification AIR 7-4 requires the Arrow to be capable of achieving an engine change within 30 minutes, without the use of special tools. To meet this requirement, the basic engine is pre-assembled into left and right hand power plants, by the addition of alternators, constant speed drive assemblies, engine attachment brackets, cooling shrouds and associated piping with quick disconnect fittings. This preparation reduces the "installed" work to connecting the engine-airframe services only.

For installation, the power plant is mounted on a dolly at the rear end of the nacelle. It is then hydraulically positioned to the correct height and angle and moved forward on the guide rail in the nacelle. During the initial installation, the forward weight of the engine is taken by a roller mounted on the engine. Four suspension points, from the under-surface of the wing, are used to attach the power plant to the airframe. These are designed to allow the wing and fuselage to flex,

UNCLASSIFIED

unopposed by the rigidity of the engine. Engine alignment is achieved by adjusting the front, centre and rear attachments.

Air for the engines is ducted from intakes positioned on either side of the cockpit. The intakes are preceded by fixed, wedge-shaped ramps adjacent to the fuselage. A sealed floating duct, in the engine intake annulus, compensates for relative flexing between airframe and power plant.

The engine nacelles and accessories are maintained at a safe temperature, by the use of natural air flow conditions existing within the nacelles, during engine running, at all speeds. This system is fully automatic and functions without recourse to actuators and controls. Where necessary, however, the nacelles are insulated from engine heat radiation by special laminated foil blankets.

The engine provides power for the following accessories and systems:

1. The accessory gearbox system, which in turn provides power for the hydraulic systems and fuel booster pumps.
2. To the constant speed drive and alternator system.
3. Engine bleed air for the air conditioning system.

An air turbine starter was selected, for its weight-saving and other advantages.



**UNCLASSIFIED**

As a result of airframe flexing under aerodynamic loads, and because of rapid temperature changes, a cable tension regulator had to be incorporated in each engine power control cable assembly. The tensioner maintains the correct setting throughout all operating conditions. The pilot may select any desired thrust, from idle to military rating plus afterburner, by the operation of a single lever control (for each engine) located in the cockpit power control box.

UNCLASSIFIED

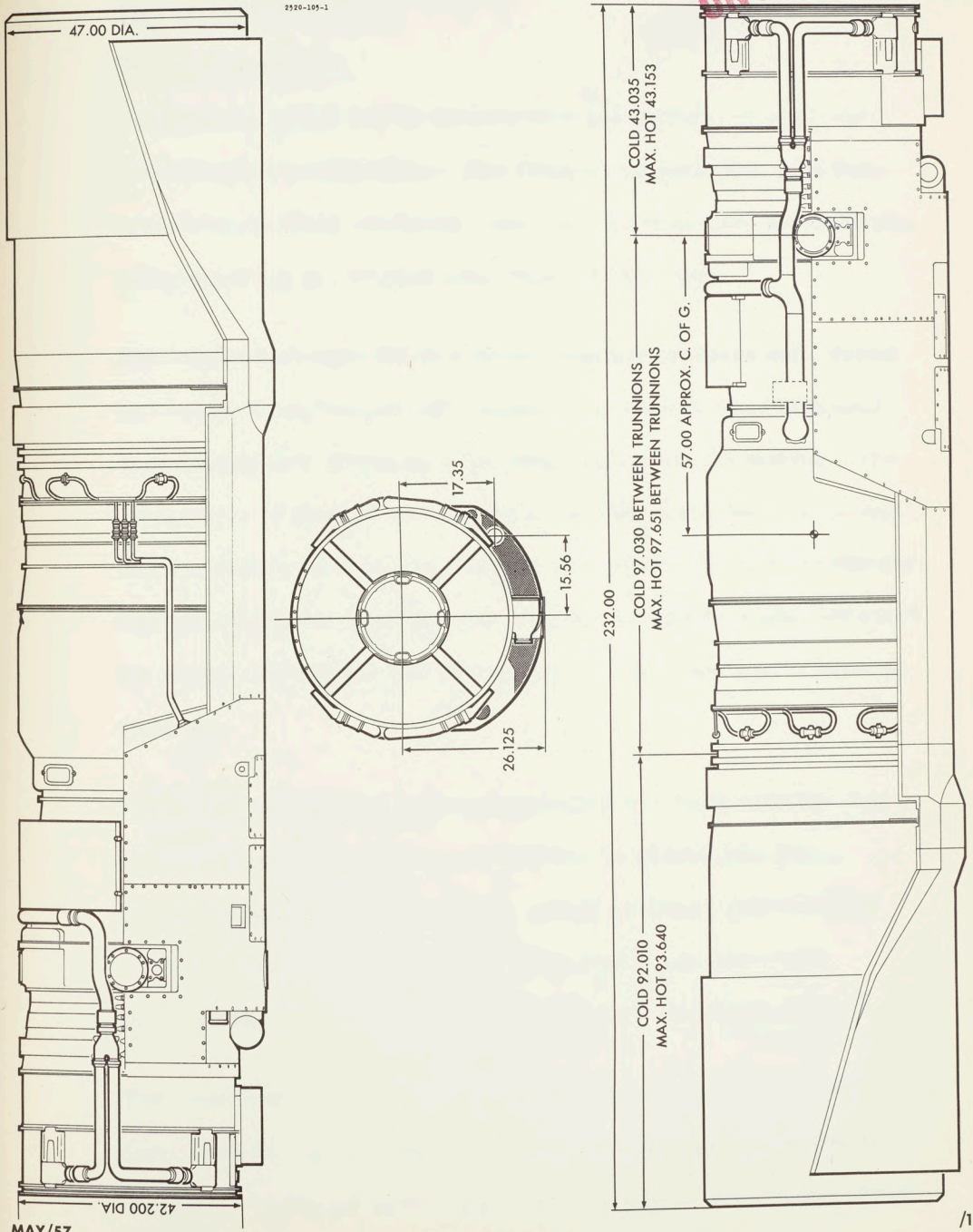

FIG. 1 MAJOR DIMENSIONS - SERIES 2 IROQUOIS ENGINE

UNCLASSIFIED

## 2. THE IROQUOIS ENGINE

### General Description

The Iroquois power unit is an axial flow gas turbine, of twin compressor spool configuration. The tandem compressors, with their respective turbines, form two rotor systems which are mechanically independent but are related with respect to air flow.

The compressor consists of a three stage low pressure unit, driven by a single stage low pressure turbine and a seven stage high pressure compressor driven by a two stage high pressure turbine. The compressor is designed for an air mass flow of 280 lbs. per second, and a pressure ratio of 8 to 1 at sea level static I.C.A.N. conditions. Compressor delivery airbleed is used for driving the engine-mounted air turbine centrifugal fuel pumps, and is also available for aircraft services.

The engine has an annular combustion system, which contains sets of vapourizing type burners. It also has an afterburner with a fully modulated convergent nozzle, which combines with the fixed afterburner shroud and the internal contour of the power unit nozzle in the aircraft forming an aerodynamic divergent nozzle.

The desired thrust is obtained by selecting an appropriate power lever position, but the power output is automatically controlled by the hydro mechanical fuel control unit in conjunction with associated temperature/pressure variables in the engine.



UNCLASSIFIED

The engine incorporates an afterburner, which is considered as part of the basic engine. The afterburner operation is fully automatic and is selected by power lever setting. The fully modulated final nozzle is used to produce the desired thrust/temperature relationship at the power lever setting selected.

The power take-off from the front of the high pressure compressor rotor drives an externally mounted gearbox, which provides direct drive for the power unit accessories and embodies a pad for the aircraft accessories drive connection.

#### Performance

Maximum with A/B	25,000 lb thrust	at	755° Centigrade
Military without A/B	20,000 lb thrust	at	755° Centigrade
Normal without A/B	18,400 lb thrust	at	660° Centigrade
90% Normal " "	16,560 lb thrust	at	622° Centigrade
75% Normal " "	13,800 lb thrust	at	562° Centigrade
Idle	700 Max	at	600° Centigrade

#### Engine Systems Starting Fuel Pumps

The engine-mounted starting fuel pump supplies fuel at a maximum output of 3,500 p. s. i. for both ground and air starts. The pump is driven by the engine hydraulic system, whose pressure has been built up by the starter rotation of the engine or by wind-milling. The operation of the pump is initiated by the "Start Button", for ground or



air start, and is shut off automatically when the fuel delivery of the main air turbine pump reaches the required pressure.

UNCLASSIFIED

#### Lubrication System

The engine lubrication system is completely self contained and of conventional design. Pressurization of the system is maintained by a "Gerotor" type lubrication pump, and scavenging is carried out by multiple element scavenge pumps. The system is pressurized by compressor bleed air, leaking through the ring type seals into the main sumps, which are vented through a centrifugal separator at the turbine outlet.

The main oil tank is serviced through an engine/aircraft pressure filling system utilizing quick disconnect couplings, for the inlet and overflow connections.

#### Ignition System

A twelve joule, high energy, ignition system is provided which utilizes 28 volt power supplied by the aircraft electrical system. Two igniter plugs per engine, of the low voltage surface gap type, initiate combustion for starting. These plugs derive their energy from the exciter and capacitator units provided on the engine.

The ignition system is inter-connected with the starting system, to provide simultaneous operation during a ground start. For re-lighting in flight, a manually operated switch is used to energize



the ignition system from the aircraft D.C. power supply.

An oxygen system is provided to improve the altitude re-light characteristics, and is automatically controlled to prevent its inadvertent operation on the ground.

**DECLASSIFIED**

2522-105-1

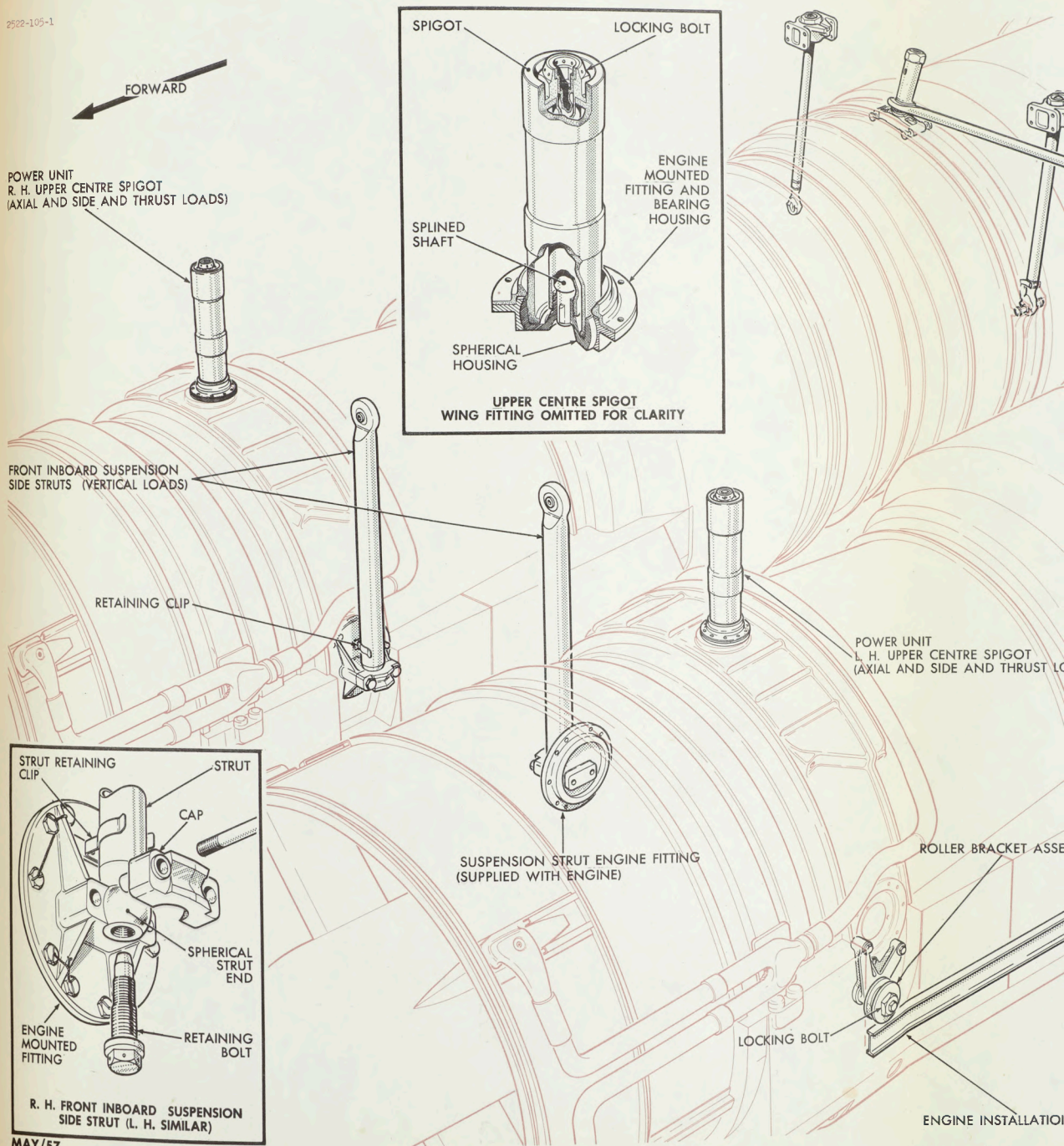

MAY/57

FIG. 2 METHOD OF ENGINE ATTACHMENT AND SUSPENSION, ARRO

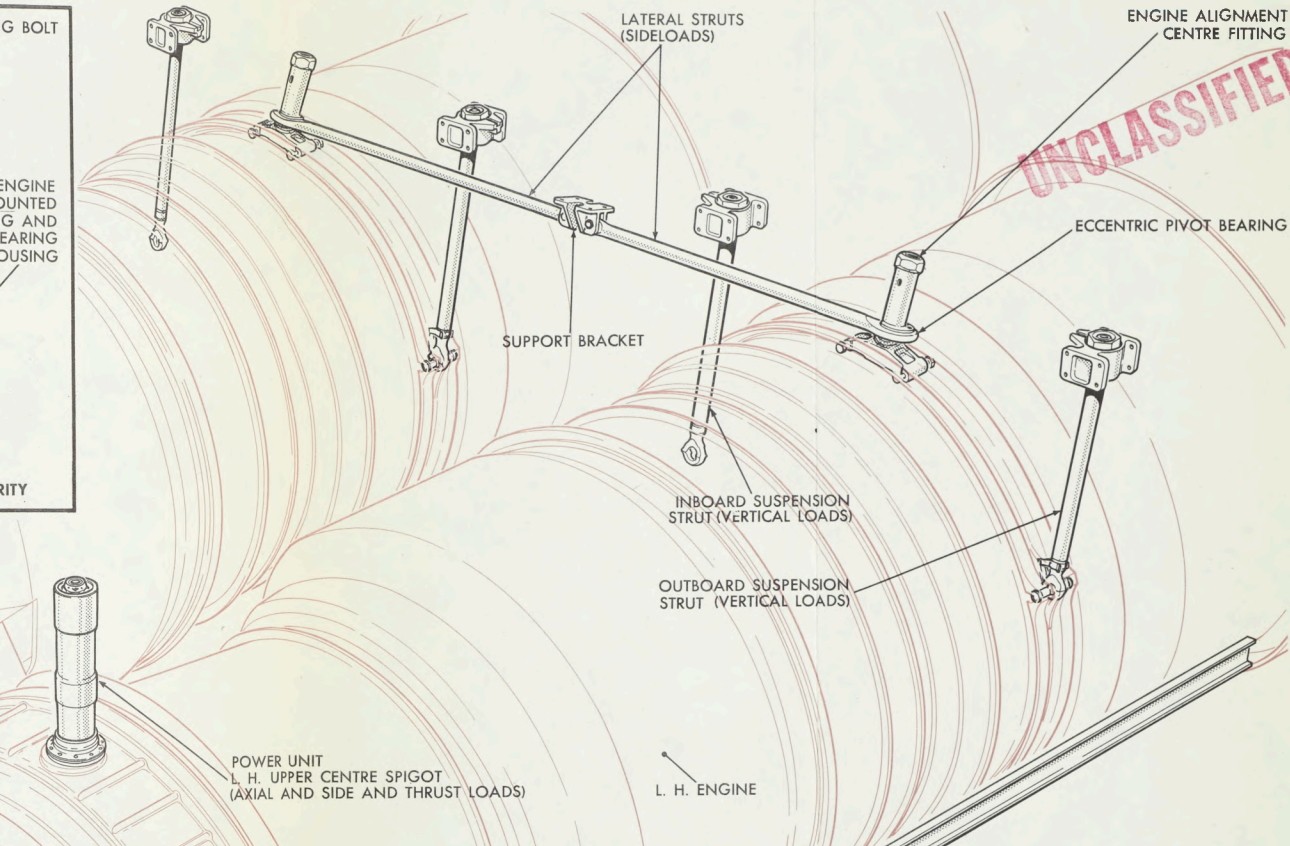

UNCLASSIFIED

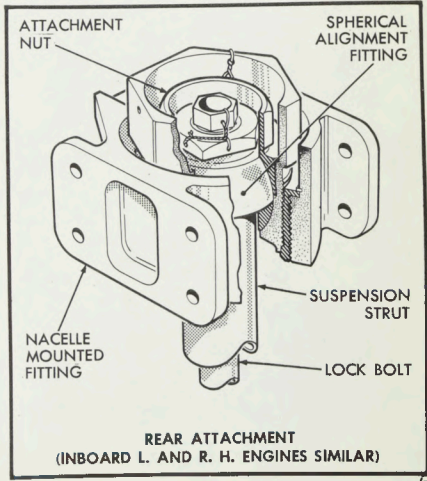
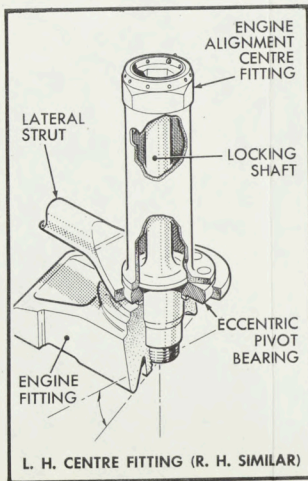
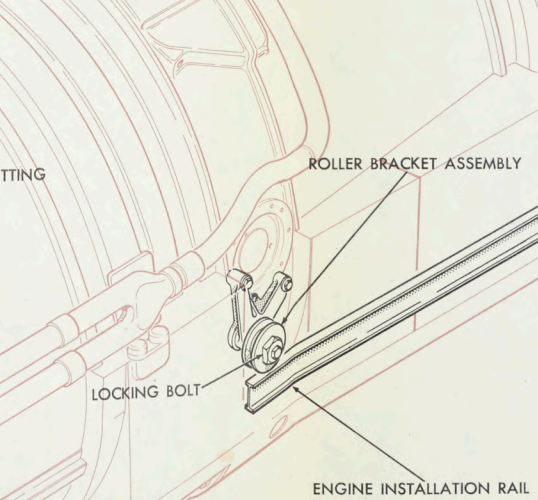

METHOD OF ENGINE ATTACHMENT AND SUSPENSION, ARROW 2/IROQUOIS

71



### 3. METHOD OF ENGINE ATTACHMENT AND SUSPENSION

#### Engine Suspension

The design of the power plant mounting assemblies, has been governed by the need to reduce all trial and error methods during installation, to a minimum.

There are two planes of attachment for securing each engine; consisting of two mounts in the forward plane, and three mounts in the rear plane. This combination ensures adequate load support under all operational conditions.

#### Forward Mounts

The mounts on the forward section of each engine comprise an upper centre spigot, designed to accept axial and side loads, and an inboard suspended side support strut, designed to carry vertical loads.

#### Centre Spigot Assembly

The upper centre spigot assembly consists of a tubular forging placed between the upper and lower wing skins; a spherical housing of forged steel which is attached to the upper forward frame of the engine; a steel forged spigot which lies within the main tubular forging (and interconnects with the engine mounted spherical housing), a locking bolt and a splined shaft. The locking bolt forms the connection between the airframe and engine suspension attachments. The



splined shaft and the spherical bearing housing, carry longitudinal and side loads in the forward plane. Access to this mount is obtained through a circular removable plate located in the upper skin of the wing.

UNCLASSIFIED

#### Inboard Forward Mount (Side Support Strut)

The inboard forward engine mounting consists of a tubular strut suspended from a forged attachment fitting located on the underside of the wing structure. The lower strut end is attached to a forged side plate bracket, which in turn is bolted to the inboard engine mounting pad. Access is gained through doors provided in the underside of the fuselage structure and in the lower engine bay shroud.

#### Rear Mounts

The mounts for the rear section of each engine comprise one centre lateral strut, designed to accept side loads, and two suspended side support struts designed to carry loads in the vertical plane. All are assembled from the upper surface of the wing.

The lateral strut is attached at one end to a supporting bracket on the wing centre box section, and the other end to an eccentric pivot bearing, which is located immediately above the top centre line engine frame attachment by a special bolt and tube assembly.

The vertical side support struts are suspended from aluminum alloy



brackets attached to the wing trailing edge box section. The lower ends of the struts are screw threaded into spherical housings carried on each side of the engine at approximately the engine vertical centre line position. Small access doors are also provided in both fuselage and shroud sidewall sections for visual examination of the lower end joints.

#### Engine Adjustment

Adjustment provisions are included at the three rear mounts to allow centralization of the engine afterburner nozzle within the airframe tail cone assembly.



UNCLASSIFIED

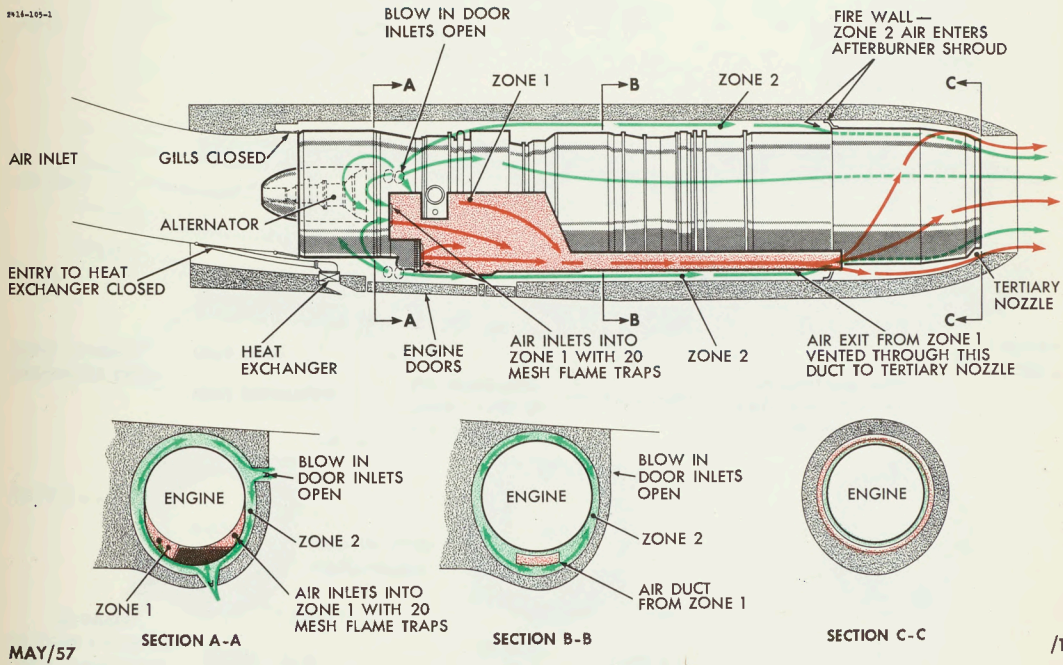
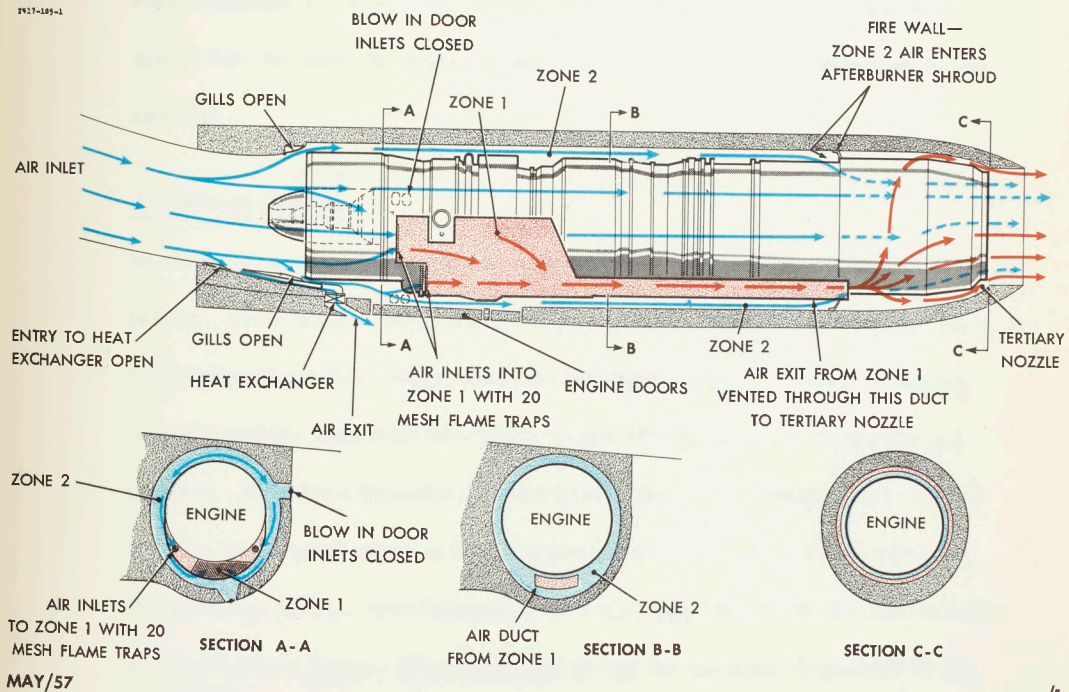

FIG. 3 ENGINE COOLING-STATIC CASE AND UP TO APPROXIMATELY MACH .50



UNCLASSIFIED



MAY/57

FIG. 4 ENGINE COOLING-FLIGHT CASE MACH .50 APPROXIMATELY AND UP

/1



#### 4. AIR INTAKE AND VENTILATING SYSTEM

##### Air Intake

A fixed geometry side air intake system, with an external compression ramp, was chosen to yield maximum installed net thrust with minimum distortion of the air flow at the compressor face with inlet flow stability over the full range of engine mass flows. The twin inlets are located on either side of the front fuselage adjacent to the cockpit.

##### Air Bleed System

In consideration of the high total pressure recovery and low distortion levels, over such a wide buzz range, it is necessary that some portion of the fuselage ("fuselage diverter bleed"), ramp ("ramp boundary layer bleed"), and duct boundary layer ("bypass") air flows be removed. The duct boundary layer bleed and ramp bleed flows help to fill the fixed inlet area at the higher Mach Numbers, thus reducing the spillage drag. The bypass bleed not only removed the low energy duct boundary layer, thus increasing the mean total pressure at the engine face, but also uses this air to cool the engine installation and to give additional thrust at the divergent ejector tail cone assembly. The ramp bleed minimizes the effect of the inlet shock and boundary layer interaction which is ducted clear of all lifting surfaces through a vent at the lower surface of the ramp. The fuselage diverter bleed removes low energy air, that would otherwise enter the intake, and



uses part of this air as the main heat sink in the air conditioning system.

The supersonic diffuser portion of the intake system consists of an external  $12^{\circ}$  two-dimensional ramp, which develops a multi-shock structure for maximum total pressure recovery.

The internal area contraction, and profile from the lip face to the throat, was determined by 6/10 scale model tests to give the required total pressure recovery, and acceptable distortion levels at low subsonic Mach Numbers, and yet not conflict with supersonic flow requirements.

The elliptic profile at the entry develops in the subsonic diffuser, to a constant area circular duct. The long length of the intake system, with its smooth bends assists flow mixing, which when coupled with the bleed systems contributes to the low distortion level existing at the engine face under all flight conditions.

#### Air Cooling and Venting

The design of airflow passages, and methods of controlling relevant air flows through the engine bays, are governed by the supersonic performance of the engine air intake.

To achieve optimum performance of the intake in the subsonic, transonic, and supersonic speed range, a by-pass passage has been

UNCLASSIFIED



designed, at the engine inlet casing, capable of taking a percentage of the engine mass air flow.

Lightly spring loaded gill flaps prevent reverse flow, under certain low forward speed conditions, which would cause a depression at the air intake inlet.

Titanium shrouds of semi-circular section isolate the engines from the aircraft structure and form separate engine compartments within the fuselage. Each compartment also forms a continuation of the air intake passages within the aircraft. This structure permits the high airflows to pass from the intake annulus by-pass duct through the space between the engine and compartment side walls, and provides a cooling air flow through Zone 1 to the accessories compartment and throughout Zone 2 for cooling the external engine surfaces and aircraft structure. The cooling and venting air flows eventually pass into the divergent ejector exit annulus and provide a small percentage of additional thrust. This additional thrust is derived by virtue of the heat rejected from the afterburner casing and passed into the by-pass airstream.

The necessary fire protection requirements are maintained by the enclosed accessories compartment which forms part of the basic engine, also by the titanium shrouds and stainless steel insulation blankets which isolate the engine compartments from the airframe.

UNCLASSIFIED



Insulation blankets are only installed within the areas adjacent to main former stations and "hot end" of each engine.

The Arrow 2 Installation provides a method of cooling and venting, to meet the requirements for both ground running and flight conditions, as described hereunder.

#### Ground Running

During ground running, and under certain low forward speed flight conditions, a depression exists at the engine intake/ duct area by-pass, resulting in the spring loaded gill flaps being drawn to the closed position. A further depression is created within the duct bay (Zone 2) and also at the aft section of the engine accessories compartment (Zone 1) under these conditions.

The depression induced during ground running, due to the jet pipe nozzle ejector action, results in the opening of sets of very lightly spring loaded doors, which open inwardly and admit an air flow to the engine compartment.

These doors are located in the fuselage wall section immediately opposite the front frame of the engine casing.

The areas of the blow-in-door inlets, are designed to ensure that sufficient cooling air can be drawn through to ventilate both Zone 1 and Zone 2. The air for Zone 1 accessories compartment, used for

UNCLASSIFIED



cooling the front section of the engine, is drawn from the forward blow-in door inlets. A percentage of this air flow is induced to enter the accessories section by means of the engine ejector nozzle creating a depression in the rear section of the compartment. Flame traps are provided, at each air entry to the accessories section, to prevent the ignition of combustible vapours within the compartment. The remainder of the air from the forward blow-in door inlets passes over the front section of the engine, and combines with the air drawn through the accessories compartment. The combined air flows pass to the ejector nozzle as a result of the induced depression.

#### Flight Operation

Conditions described above apply during ground running, and under the flight conditions defined, until the aircraft has reached a forward speed high enough to create a static pressure higher than ambient within the air intake duct, in which case the by-pass gills, situated at the engine air inlet section, will open due to ram intake pressure, and ventilation will be maintained as previously described with the cooling air being provided by engine spillage.



## 5. ACCESSORIES DRIVES AND GEARBOX

### Installation, and Lubrication Systems

#### General

The accessories drives and gearboxes consist of two separate systems each having a separate lubrication system. One system is used for an alternator and incorporates a constant speed unit and the other system employs a gearbox for driving hydraulic pumps. The gearbox incorporates a vertical drive to supply rotary power to the fuel booster pump positioned on the wing under-surface. The gearbox has an independent lubrication system, and the alternator/constant speed unit lubrication system is integrated with the engine oil system. The two systems are similar for each engine.

#### Constant Speed Drive Unit

The low pressure compressor shaft power take-off point is utilized to drive constant speed unit which in turn drives an oil cooled 40 K.V.A. alternator. The constant speed drive unit, comprising a hydraulic pump and motor is mounted directly to the engine pad provided on the front of engine casing in the annulus of the engine intake. A flange at the output end of the drive unit accommodates the alternator. The complete assembly is enclosed in a fairing in the form of a conventional "nose bullet", and is mounted on the engine adjacent to the constant speed drive attachment flange. A controlled flow of engine compressor air, at elevated temperatures is directed to the nose bullet for anti-icing purposes.

UNCLASSIFIED



The constant speed unit converts a variable input speeds of between 2100 R. P. M. and 6000 R. P. M. , to a constant 8000 R. P. M. output, with a 1% steady state variation, and up to 5% transient condition variation.

UNCLASSIFIED

#### Constant Speed Drive Lubrication System

The oil supply required to operate and lubricate the fluid drive sections of the constant speed unit, and to cool the alternator, is tapped off a section of the main engine oil circuit. The pressurization of the engine supplied oil is provided by an integral pump within the constant speed unit. The scavenge oil is returned to the engine circuit, having first passed through an oil-to-air and oil-to-fuel heat exchanger system, by means of an integral pump.

The integrated oil system of the engine and alternator/constant speed unit has been designed to ensure that the engine oil supply and return temperature does not exceed 300°F.

The oil services, to and from the alternator and constant speed drive unit, are carried through the hollow faired struts of the air intake frame assembly.

#### Accessories Gearbox Installation

The engine accessories gearbox, mounted on the lower section of the front frame, is driven by a bevel gear drive from the forward end of the high pressure compressor rotor, and conveyed through a vertical



shaft, to the lower centre line of the front frame. The various engine accessories are mounted on the forward and rear sections of this gearbox. From the centre drive attachment flange, in the forward face of this gearbox, provision is made for the aircraft accessories power take-off. A drive on the rear face of the gearbox is provided for an air turbine starter unit.

An angled gearbox is mounted on the accessory drive pad. A drive shaft connects this gearbox to a similar gearbox, which forms part of the main accessories power take-off gearbox unit. The connecting drive shaft has universal joints at both ends which combined with end-float provides the necessary flexibility between the engine and gearbox. To facilitate engine removal, the main gearbox drive-shafts are provided with quick disconnect couplings. Shear sections are also provided to protect the engine gearbox in the event of main accessory unit failure.

The main gearboxes driven as described on the previous page are centrally located side by side in the equipment bay between the engine bay inner side walls. Each gearbox carries four output drives, two facing aft for driving the hydraulic pumps supplying power for the flying controls, and one on the forward face driving a constant pressure hydraulic pump for the utility services. A vertical drive is fitted to the top face of the gearbox to provide power to the collector tank fuel booster pump.



The vertical drive shaft is connected to a small gearbox mounted on the underside of the wing. This gearbox carries an output shaft driving forward to a second gearbox attached to the underside of the collector tank, and drives the centrifugal fuel booster pump mounted therein. Since the drive shaft between the two gearboxes is approximately 5 feet long, a steady bearing has been placed at the mid-point.

All the shaft joints in the sub-system are sufficiently flexible to accommodate deflections within the airframe.

A disconnect joint is provided in the vertical drive shaft from the main accessories gearbox to facilitate removal and installation of shaft and/or gearbox.

The lower part of each main gearbox casting is used as the accessories gearbox oil reservoir, each holding one gallon of oil. Provision for pressure filling, and checking each oil level by sight glass is made.

Both main accessory gearboxes are mounted on a removable panel, which attaches to the fuselage structure.

Access for hydraulic pump removal, gearbox servicing, and inspection is obtained through two centrally positioned access doors, forward and rearward respectively, of the main gearboxes.



### Accessories Gearbox and Drives Lubrication System

The right and left hand accessories gearbox and drives are each lubricated by a separate sealed pressure system, independent of the engine oil system. The system is provided with spur gear pumps which scavenge the mixed oil and air. A combined centrifuge and de-aerator tank is incorporated in the system to separate oil and air prior to cooling and re-circulating.

### Oil Cooling

Oil is cooled by an oil-to-air heat exchanger and then by an oil-to-fuel heat exchanger. The oil-to-air heat exchanger is positioned in the engine intake airstream adjacent and below the engine intake adaptor ring. The oil-to-fuel heat exchanger is positioned forward and between the engines in the centre equipment bay.

### Oil Feed

The cooled oil from the heat exchangers is passed through a filter and circulated to the accessories gearbox drive gears, the main accessory gearbox, the fuel booster pump, and the top corner gearbox. Oil from the outlet side of the filter circuit is also fed to the power take-off gearbox assemblies.

Bulkhead connectors are provided to allow oil lines to pass through the engine nacelle duct and fuselage structure.



### Air System

An air supply, of approximately 5 to 7 p. s. i. is tapped off the main engine compressor bleed system, and is piped to the propellers gearbox, power take-off gearboxes, and the constant speed drive unit. Cavitation conditions at altitude and thereby obviated.

UNCLASSIFIED

2990-149-1

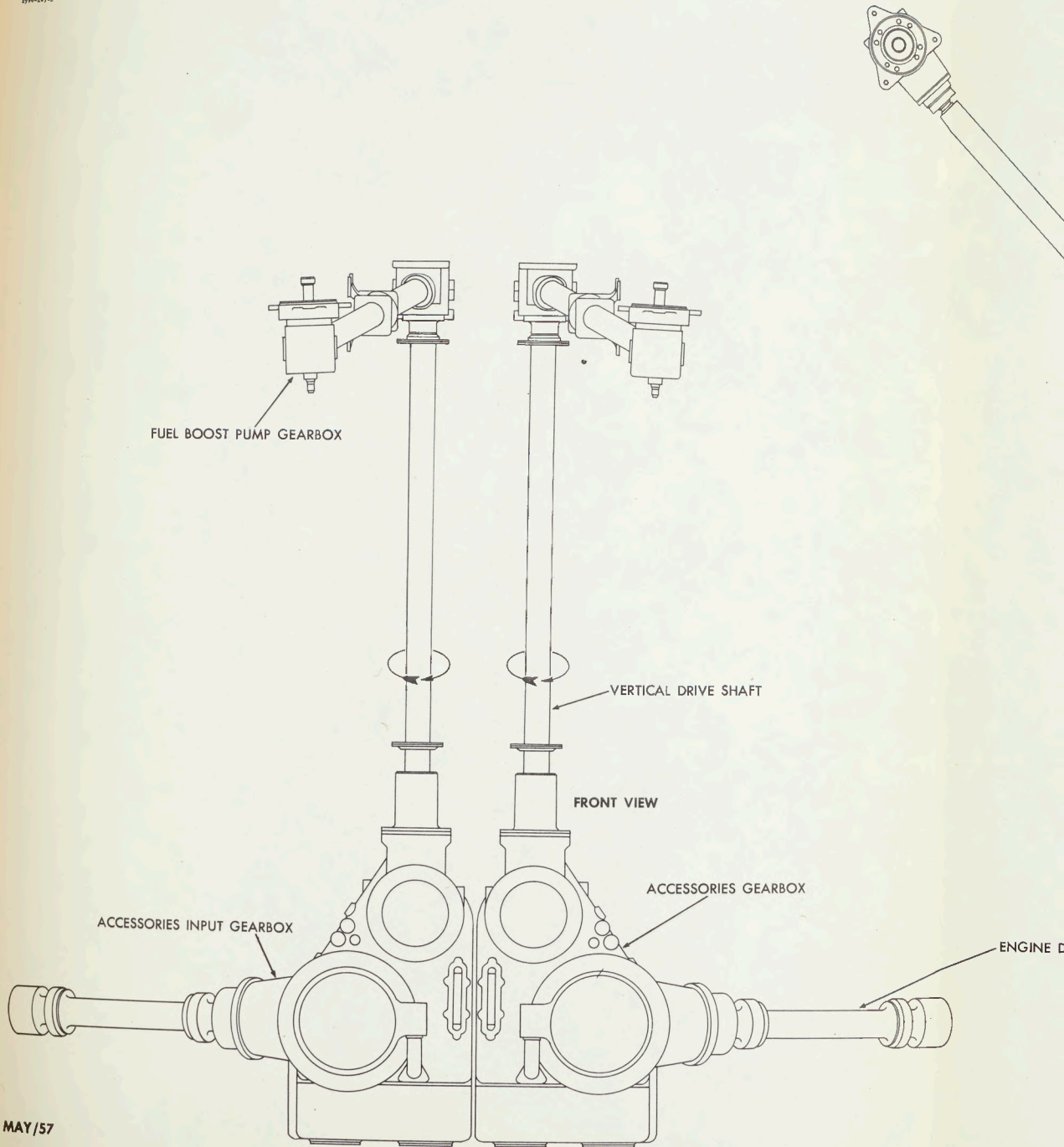

MAY/57

FIG. 5 ACCESSORIES GEARBOX



UNCLASSIFIED

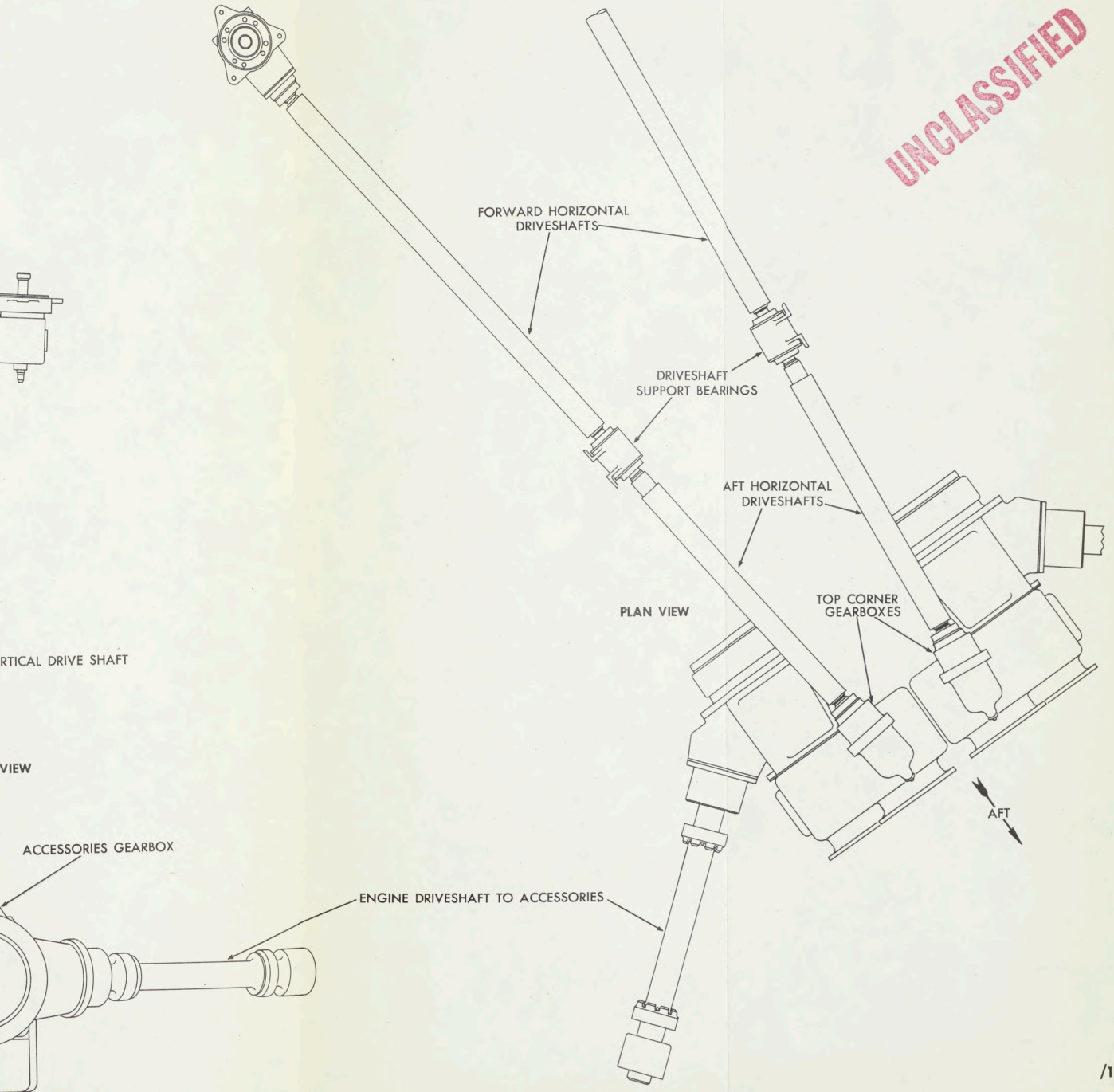
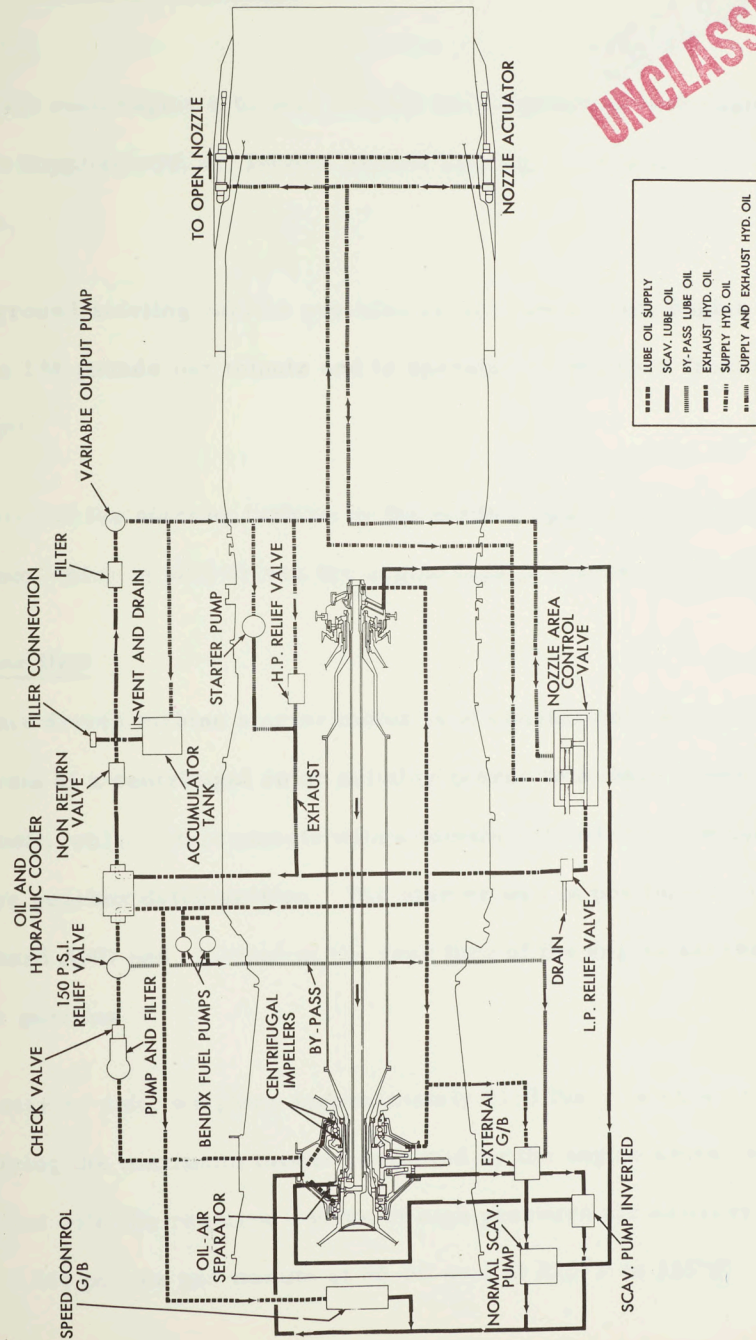

FIG. 5 ACCESSORIES GEARBOX



UNCLASSIFIED

2521-109-1



MAY/57

FIG. 6 SCHEMATIC OIL AND HYDRAULIC SYSTEMS

/1

**UNCLASSIFIED**

## 6. ENGINE STARTER SYSTEM

### General

To start each engine a turbine starter unit is fitted to each engine and is supplied with air from a ground starting vehicle through air hoses.

The ground starting vehicle provides an air flow to each engine at 112 to 148 pounds per minute and is operated by switches from the cockpit.

Rotation of the starting turbine by the airflow applies torque to a gearbox which in turn drives the engine high pressure compressor.

### Starter Unit

The air driven turbine starter motor is of conventional design, and consists of a centrifugal rotor suitably geared to a main power take-off shaft, which interconnects with a female splined fitting within the engine gearbox drive section. The starter unit is positioned on a standard AND pad, located at the rear face of the engine accessories drive gearbox.

The starter unit, weighing approximately 21.5 lbs., is capable of supplying the maximum torque permitted by the engine drive, when supplied with the required source of high pressure air delivery of 112 to 148 pounds per minute at 50-60 psia at 225°F to 325°F.

Access to the starter unit, located within the fireproof engine accessories compartment, is obtained through a removable access panel, and also through the aircraft main service doors on the underside of the fuselage. There are smaller doors to permit the attachment on an air hose to the starter inlet connection of each engine. The smaller doors are designed to close automatically, as the hose connection at the starter is disconnected.

#### Automatic Coupling

A "Wiggins", lanyard coupling, is used to give an automatic and instantaneous break-away between the aircraft and ground power supply vehicle, during "scramble" operations.

When the aircraft commences to taxi away from the starting point, the lanyard, which is attached to a fixed point on the ground, triggers a spring in the air hose coupling which instantly ejects the coupling from the starter connect unit. As soon as the coupling clears the aperture the door will close and lock.

#### Operation

The starter embodies a single pole, double throw, centrifugal switch, which actuates when the engine high pressure compressor speed of approximately 2000 R. P. M. is reached. Provision is made for a standard electrical fitting on the starter housing to connect with the aircraft electrical circuit, in conjunction with the electrically actuated air inlet valve for pneumatic services.

The aircraft electrical circuit on the Arrow 2, provides an automatic starting sequence as described below, and assumes that ground electrical and pneumatic services are connected as previously described.

The starting cycle is initiated immediately the power lever is placed from the "OFF" to the "GROUND IDLE" position, and the starter switch selected to "START".

This action starts the following mechanical and electrical sequence of operations automatically:

- (a) Selection of the switch to "START", immediately energizes the appropriate ignition circuit, opens the air valve in the ground starter vehicle, and air pressure becomes available to the starter motor.
- (b) After light-up has occurred and the high pressure compressor speed reaches approximately 2000 RPM the centrifugal switch within the starter motor shuts off the ignition, also closes the air supply valve in the starter vehicle.

In order to carry out a motoring run without the ignition circuit energized, the starting switch is selected to the "MOTOR" position, which opens the air supply valve. It is, however, necessary to hold the switch in this position up to the maximum time permissible, and then release in order to close the air valve.

Starting time will be almost entirely dependent upon the following factors:



UNCLASSIFIED

- (a) The amount of torque supplied by the particular starter.
- (b) Serviceability of ignition equipment.
- (c) Ambient temperature conditions.
- (d) Accessory loading.

The engine should "light-up" within 20 seconds from the time that the engine start switch is operated. This 20 second time interval is an arbitrary value, established primarily to preclude personnel "grinding" away with the starter indefinitely on a temperamental engine. Experience will establish a recommended time limitation for the Arrow 2 installation.

#### Lubrication

A threaded screw type plug is provided and placed in an accessible position on the starter body in order that the lubricant can be replenished, and its level determined.

The starter unit uses lubricating oil to Specification MIL-L-7808.

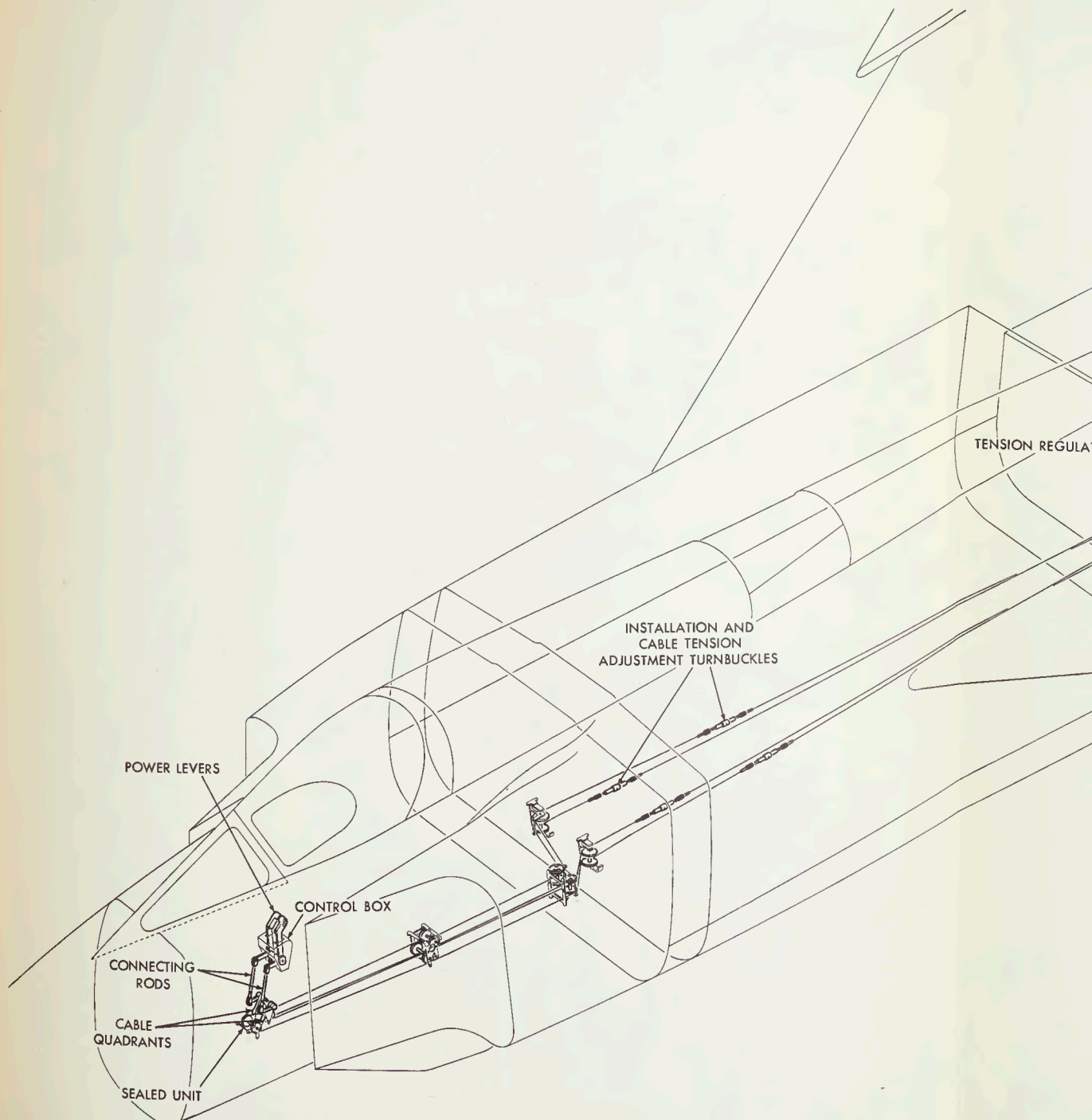

MAY/57

FIG. 7 ARROW 2 ENGINE CONTROLS - SCHEMATIC (PR



UNCLASSIFIED

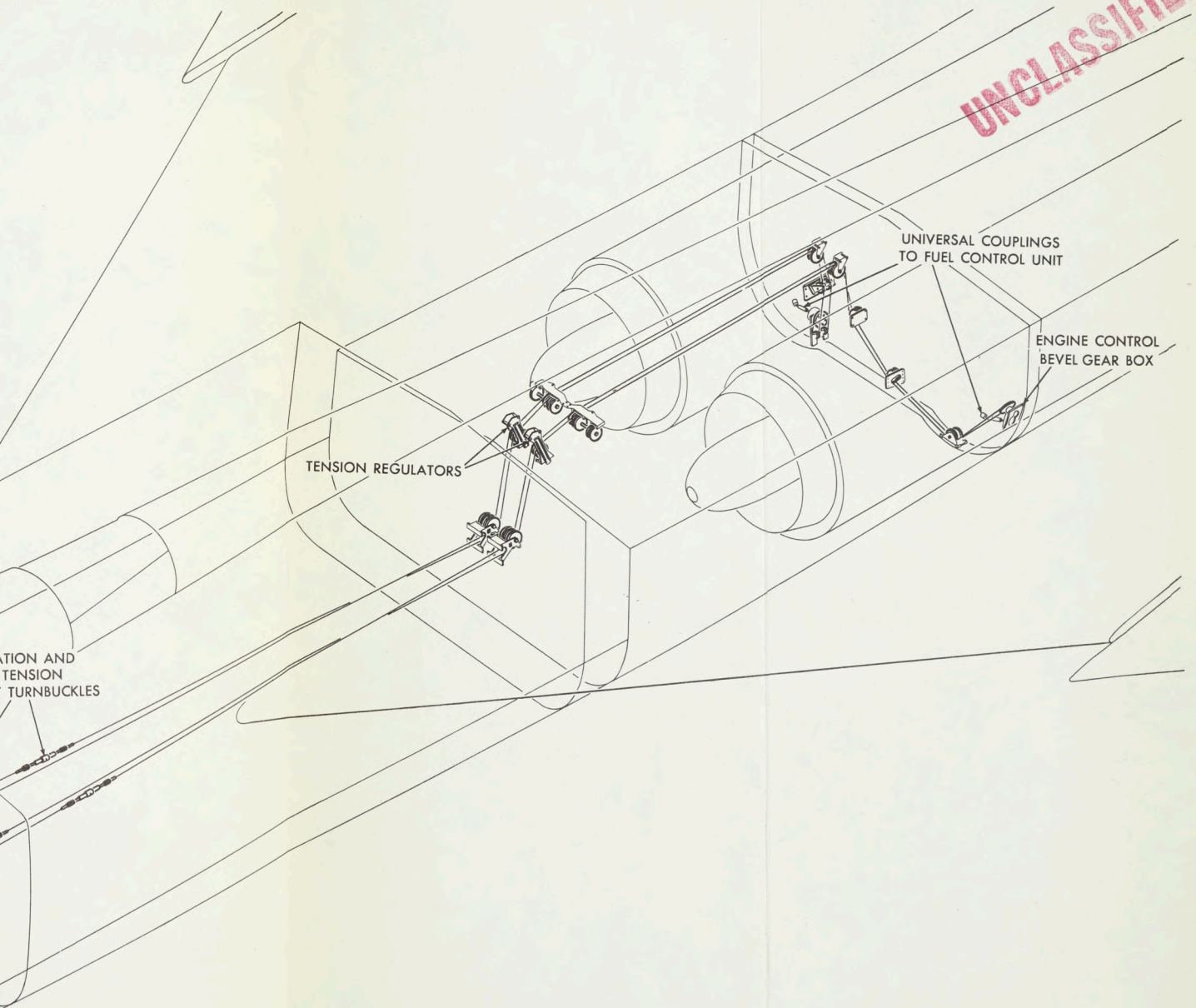

ARROW 2 ENGINE CONTROLS - SCHEMATIC (PROVISIONAL)



UNCLASSIFIED

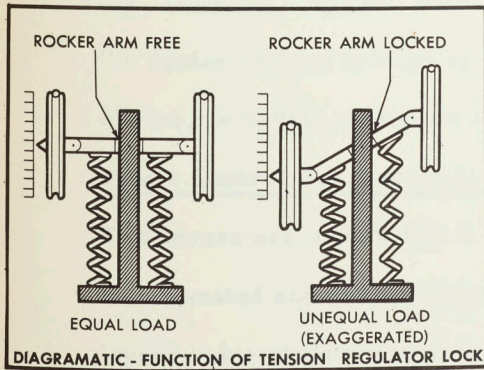
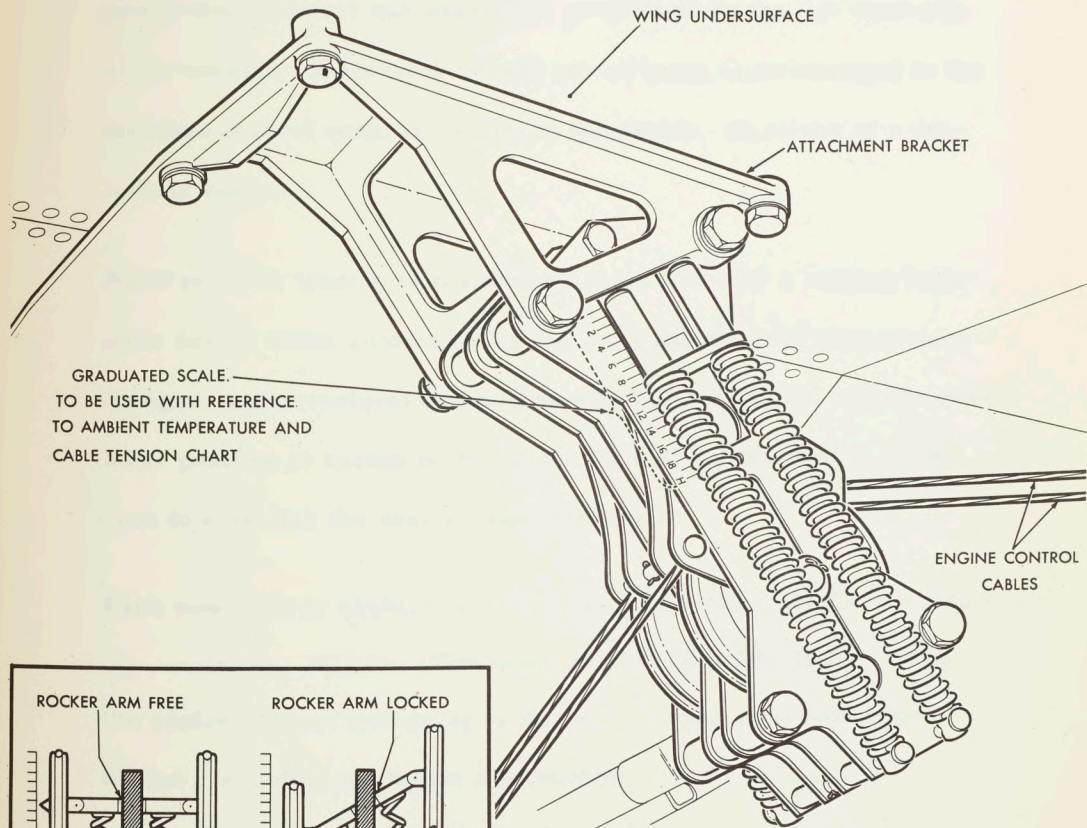

FIG. 8 CONTROL CABLE TENSION REGULATOR



UNCLASSIFIED

## 7. ENGINE POWER CONTROL SYSTEM

### General

Power is selected manually by the pilot through a conventional twin power lever control box assembly, positioned on the left hand side of the cockpit. Movement of each power lever is transmitted to the fuel flow control quadrant shaft, at the engine, by means of a continuous cable.

Positive cable tension is maintained at all times by a tension regulator device which automatically corrects for ambient temperature changes, and structural deflections within the fuselage. As the power lever position is varied by the pilot, the fuel control unit is called upon to establish the desired engine thrust.

Each power lever enables positive selection to be made for the following conditions: "OFF", "GROUND IDLE", "FLIGHT IDLE", also the desired thrust ratings up to the military and maximum conditions, including maximum afterburner.

### Power Control Box Assembly & Control Run

Two levers are mounted on a common shaft with friction loading incorporated and are contained within the control box housing. The levers transmit lever movement, through adjustable rods, to a sealed bell-crank unit located between the upper and lower surfaces of the cockpit floor. This latter design feature ensures sealing of the cockpit in the bell-crank area, under maximum pressurization conditions.



The control quadrant is divided into the following sections, which cover a total range of movement from zero to  $60^{\circ}$  on the control box giving a range from zero to  $110^{\circ}$  at fuel flow control unit shaft indicator.

- (a) "OFF" is selected by moving the power levers fully rearward against the stop. The power lever is retained in the "OFF" position by a spring load mechanism. No adjustment is provided at this position, except at the engine fuel control unit.
- (b) "GROUND IDLE" is a positive detent position a few degrees forward from the "OFF" position; giving an engine speed of 2000 R. P. M. ( $N_1$ ) lever movement from "OFF" to "IDLE", will open the high pressure fuel cock in the flow control unit and schedule the required "IDLE" flow.
- (c) "FLIGHT IDLE" is selected by moving the levers forward from the ground idle position to a mechanical detent to give an engine speed of 2500 R. P. M. ( $N_1$ ). To select a power lever position above "FLIGHT IDLE" a force of approximately 10 pounds will have to be exerted to over-ride the flight idle detent.
- (d) "MILITARY AND MAXIMUM" (Non Afterburning/Afterburning)  
A progressive forward movement over the remaining 75% of the full range, will select the following conditions:
  - (a) Up to "Military Thrust Rating", without afterburning.
  - (b) "Military Thrust" plus progressively increased afterburner



thrust up to "Maximum" rating with full afterburning.

Positional control of each power lever is confined within the afterburner range by a swivel type latch, spring loaded and located within the control box housing. This permits afterburner "Light Up" at a position on the engine control shaft quadrant of approximately 93 degrees, and positions the afterburner shut-down point at 78 degrees. In consequence supplementary afterburner thrust can be modulated from maximum down to the point of afterburner cut-out.

At the military thrust rating position of the power lever a swivel type latch incorporating two segments is fitted to the control box. A forward movement of the power lever beyond the military position will require a deliberate movement and an exerted force of 10 to 13 pounds applied to the lever to override the latch segment and to reach the "AFTERBURNER ON" position. The military rating position is therefore a 'latch' stopped position. When the supplementary afterburner thrust is required, the 10 to 13 pounds is applied to the lever and the lever moves into the afterburner range. With afterburner 'ON' thus selected, the thrust and power lever position can be increased to "AFTERBURNER MAX." which is the maximum rating permissible and at the power lever full travel position at 60°.

Operating the lever to a retarded position from "AFTERBURNER ON" to "AFTERBURNER OFF" operates the swivel latch in a similar



manner to that described above, and with the same force applied requirements. The swivel latch by which the lever is confined within the afterburner range, automatically resets and assumes a position ready for subsequent power lever settings.

#### Throttle Box Assembly and Control Run

Motion is transmitted through the cockpit floor by a connecting rod and then to cables attached to the lower fulcrum bellcrank levers at Station 152. The twin cables are guided by a series of pulleys that lead the cables to the engine compartment where each transmits motion from its respective cockpit power control lever to the respective engine fuel control unit. The engine control cables that pass through the armament bay are guided and protected also by fairleads fitted to the armament bay roof.

The cables are joined and adjusted for length and tension by conventional turnbuckles, located at positions below the armament bay roof at Stations 268 and 359. The end of each cable has a swaged ball end fitting at the point of attachment to the sealed quadrant unit bellcrank. The cables terminate at the engine nacelle gearbox assembly, to which is attached a universal jointed connecting rod and quick-connect coupling. This attachment provides the flexible coupling between the nacelle gearbox and the engine fuel flow control unit shaft.

#### Cable Tension Regulator Unit

Cable tension regulators are incorporated in each engine control



system in order to automatically maintain adequate cable tension and synchronization of movement between each cockpit lever and fuel flow control shaft position, under the following conditions of operation:

- (a) Aircraft structural deflections in the longitudinal axis.
- (b) Ambient temperature changes affecting structural materials.
- (c) Accumulation of minor tolerance build-up due to progressive wear on pulley assemblies and cable elongation.

Each cable tension regulator consists of a frame assembly embodying two pulley wheels, which are held within the frame by a rigid shaft moving longitudinally in guide slots, and held in constant tension by springs.

The mechanism permits each pulley wheel to move either up or down, within the regulator body, governed by a pre-set spring load. A graduated scale on the face of the mechanism assists in correctly calibrating each control during installation and subsequent maintenance inspection.

The scale is referenced to a chart which determines setting on the scale for the ambient temperature and shows the amount of tension desired. This unit will compensate tension by permitting the pulley wheels to move within their guide slots up to a maximum of 2.5 inches travel.

A locking device is incorporated between the two pulley wheels,

preventing individual movement within the compensation range due to any sudden loading change occurring on either cable. This is simply effected by uneven tension occurring between the guide assemblies, causing subsequent mis-alignment in travel and restriction of movement within the particular guide. This arrangement ensures that the control position selected is maintained within limits.

#### Gearbox and Coupling

Connection and transmission of movement from the cable assembly to the engine fuel flow control unit is through a small gearbox drive unit on both left and right hand installations immediately opposite the engine fuel control unit. Connection is by a short drive shaft embodying a universal ball joint at each end, one end of which is permanently attached to either gearbox.

The opposite end of the shaft has a "quick" release disconnect type coupling, which interlocks with an associated fitting attached to the quadrant shaft of the engine flow control unit. A spring tensioned steel tongue locks the slotted "quick" disconnect nut.

The gearbox units for each engine are charged with high melting point grease to specification MIL-G-3278 prior to installation, and at the appropriate inspection periods.

UNCLASSIFIED



AVRO AIRCRAFT LIMITED

2734-105-1

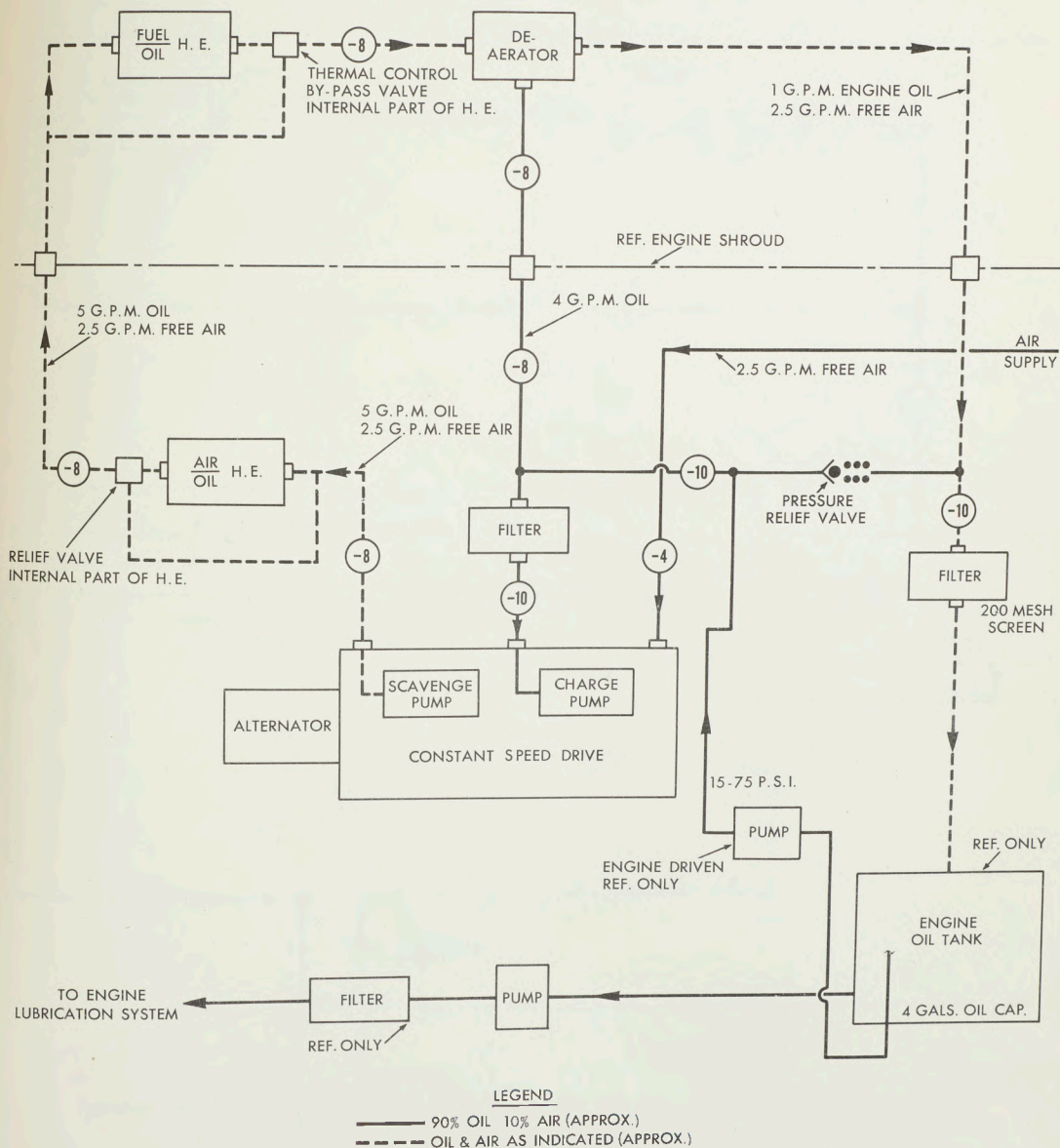

/1

ARROW 2 CONSTANT SPEED DRIVE INTEGRATED OIL SYSTEM



AVRO AIRCRAFT LIMITED

2735-105-1

FLOWS SHOWN ARE AT MAXIMUM ENGINE R.P.M. AND  
MAXIMUM OPERATING FLUID TEMPERATURE IN U.S. G.P.M.

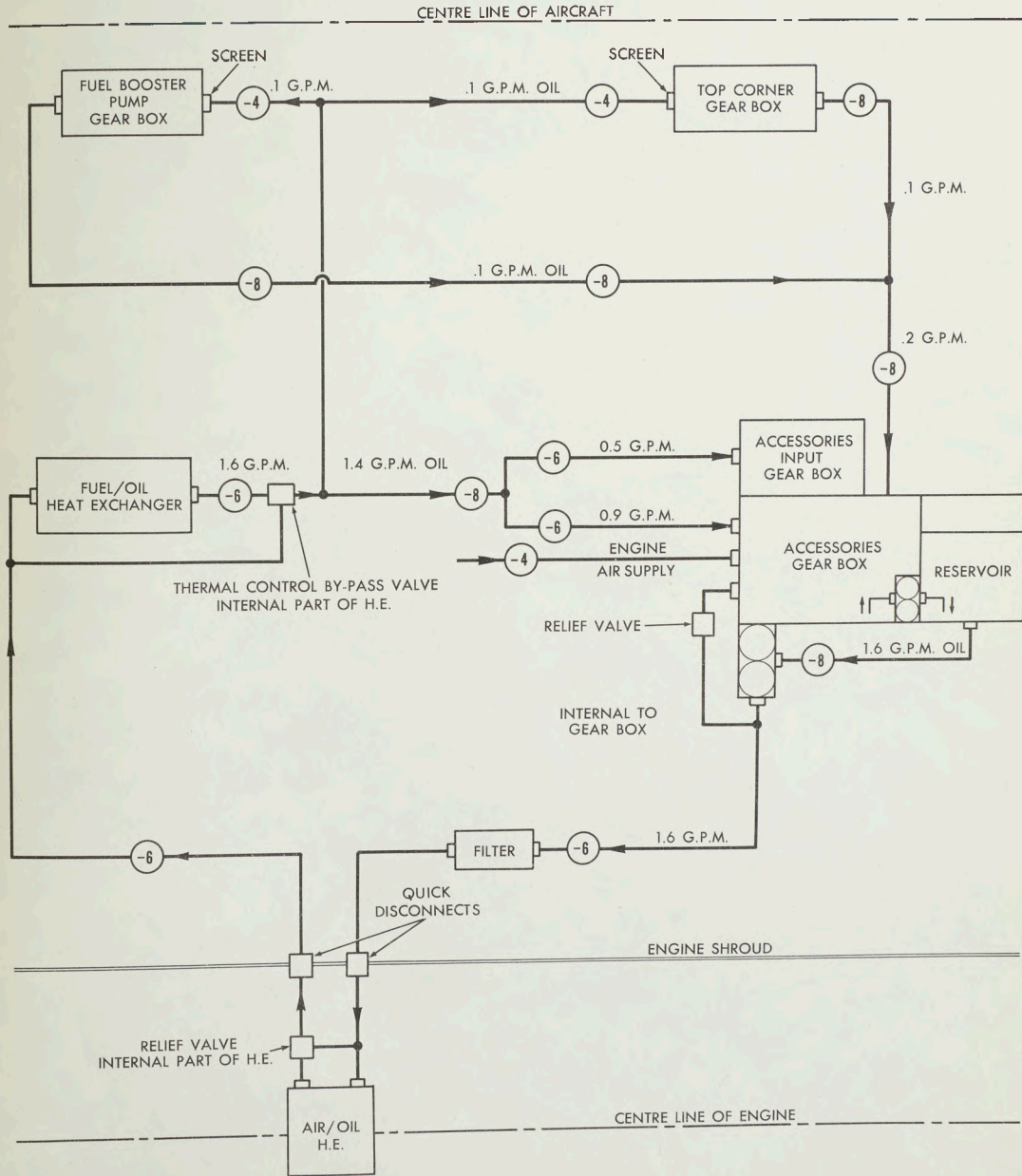

ARROW 2 ACCESSORIES GEAR BOX OIL COOLING SYSTEM

