

QCA
Auro
CF105
P-Stab.-
137-Iss.2

UNCLASSIFIED P/Stability/137
Classification cancelled / Changed to UNCLASS
By authority of CF-105 AVS
Date DAMPING SYSTEM DEVELOPMENT Sept
Signature [Signature] March 1957
S. Kwiatkowski
Unit Rank / Appointment

FILE IN VAULT
NRC DISM
J. H. PARKIN
BRANCH
MAY 11 1995
ANNEXE
J. H. PARKIN
CNRC - ICIST

ANALYZED

15855696



A V ROE CANADA LIMITED
MALTON - ONTARIO

TECHNICAL DEPARTMENT (Aircraft)

AIRCRAFT CF-105

REPORT No. P/Stability/137

FILE NO.

NO. OF SHEETS: 38

TITLE:

CONFIDENTIAL

CF-105

DAMPING SYSTEM DEVELOPMENT.

Classification cancelled/changed to ISSUE 2, ABS
by authority of AVPS (date) 27 Sept 56
Signature P. Kelly Rank DS 5

UNCLASSIFIED

PREPARED BY S. Kriatkovski ^{SE} DATE June 1957

CHECKED BY _____ DATE _____

SUPERVISED BY _____ DATE _____

APPROVED BY J. Chamberlain DATE June 1957

ISSUE NO.	REVISION NO.	REVISED BY	APPROVED BY	DATE	REMARKS

CONFIDENTIAL

CONFIDENTIAL

This Report Is A Non-Contractual
Document Intended For Internal Circulation

It presents a brief account of the development of
the damping system, it's functional description,
Status of work as of March 1st, 1957, proposed
test programs and associated analytical work.



AVRO AIRCRAFT LIMITED
MALTON - ONTARIO

TECHNICAL DEPARTMENT

REPORT NO P/Stability/137

SHEET NO 1

AIRCRAFT:

C-105

UNCLASSIFIED

PREPARED BY

DATE

S. Kwiatkowski

March/57

CHECKED BY

DATE

CONTENTS.

	<u>Page</u>
1. Introduction	1
2. General Requirements	5
3. Functional Description - Normal Damper	7
3.1 Pitch Axis	
3.2 Roll Axis	
3.3 Yaw Axis	
4. Functional Description - Emergency Damper	17
5. Status of Work as of March 1st, 1957	19
6. Test Program	21
7. Associated Programs	23
8. Appendix	25
9. Block Diagrams	

ADDITIONS - 25th JUNE 1957.

3. Rudder Monitor	18a
"G" Limiter	18c
5. Status of Work - June 25th, 1957	20a



AVRO AIRCRAFT LIMITED
MALTON ONTARIO

TECHNICAL DEPARTMENT

REPORT NO. P/Stability/137

SHEET NO. 1

AIRCRAFT:

CF-105

PREPARED BY

DATE

S. Kwiatkowski

March 1957

CHECKED BY

DATE

UNCLASSIFIED
CONFIDENTIAL

CF-105

DAMPING SYSTEM DEVELOPMENT

1. INTRODUCTION

The necessity of automatic improvement of flight characteristics of the C-105 was clearly indicated by early estimates and Wind Tunnel Tests carried out in September 1953. Due to a large range of speed and altitudes it has been found impossible to rely only on natural damping of the airplane to provide an adequate weapon launching platform, at high altitudes (60000 ft) and at the same time maintain reasonable performance. In this situation it is evident that the aircraft will not be operational in case of failure of the electronic damping system equipment. In particular, a deficiency in weathercock stability and yaw is usually experienced in supersonic designs, since it is very difficult to make the vertical fin sufficiently large and effective. Because of this, the decision was made in the early stage of design to increase the scope of electronic equipment to include stability augmentation, thus permitting marginal aerodynamic design. Reliability is achieved by complete duplication of vital parts of the damping system. The scope of the damping system was extended further to include desired feel characteristics through the adoption of control stick steering system. In such a system feel is controlled electronically and cumbersome artificial feel devices are not needed. Such a system is also particularly well suited for integration with automatic modes (fire control, automatic navigation).

Under these broad outlines the work started in 1954 and two proposals from M-H and Hughes Aircraft Co. were submitted namely:

- a. "Honeywell's E-10 integrated flight control system for the A.V. Roe Canada C-105 - 8th, September 1954."



AVRO AIRCRAFT LIMITED
MALTON - ONTARIO

TECHNICAL DEPARTMENT

REPORT NO. P/stability/137

SHEET NO. 2

AIRCRAFT:

C-105

UNCLASSIFIED

PREPARED BY

DATE

S. Kwiatkowski

March 1957

CHECKED BY

DATE

INTRODUCTION (Continued)

- b. Hughes Aircraft "An Electronic System for the C-105 Interceptor" - 23, December 1954.

At Avro main efforts during 1954 were expended in finalizing the aircraft configuration and testing and estimating the aerodynamic properties required for the design of the damping system. Flying control system was laid out and specifications for hardware items were prepared. Also an analog computer was ordered and received in part and a limited amount of work in the dynamic analysis field was carried out. The Hughes Aircraft Co. received a letter of intent to proceed with the development of the manual mode damping system on November 29, 1954 to the extent of \$ 30000. Consequently a proposal was submitted in February 1955. A series of negotiations followed and analytical work was carried out on both sides resulting in revised requirement submitted to Hughes in November 1955. More analog equipment was acquired by Avro permitting more extensive analysis and the writing of specifications for some flying control hardware. The progress of work was hampered by the lack of final aerodynamic supersonic data and changes introduced due to configuration modifications. Furthermore the analog equipment was still inadequate to carry out full simulation and Hughes were proceeding rather slowly due to some contractual problems. Finally in April 1956 upon being informed that they were not to undertake the development of the weapon system the Hughes Aircraft Co. stopped work on damping system by mutual agreement. The final report was issued in September 1956. In the meantime work has been transferred to Minneapolis-Honeywell in June 1956. The system proposed by Hughes was transmitted to M-H but unfortunately the results could not be applied directly to M-H work. The Hughes proposal included circuitry and mechanisation techniques not compatible with M-H experience in this field, and substantial changes were required. Furthermore as work progressed the anticipated aerodynamic coupling problems came to light through an advanced five degree of freedom simulation using supersonic wind tunnel data obtained at Langley Field in September 1956. Further changes of damper configuration and hardware components had to be made.



AVRO AIRCRAFT LIMITED
MALTON - ONTARIO

TECHNICAL DEPARTMENT

REPORT NO. P/Stability/137

SHEET NO. 3

AIRCRAFT:

C-105

PREPARED BY

DATE

S. Kwiatkowski

March 1957

CHECKED BY

DATE

CONFIDENTIAL

INTRODUCTION (Continued)

Important consideration during this period was low speed damper configuration. At first the idea of a separate low speed mode was followed, but a complicated system resulted. Eventually the normal damper was modified in order to cover low speed range. The system was finalized in a series of meetings during January 1957. At these meetings an important change was introduced regarding the basic sensor for stability augmentation. The results of the development of the $\alpha - \beta$ vane indicated that to achieve satisfactory results a further development program would be necessary. A suitable accelerometer however was available. Contributing factor was inability to sense total pressure with required accuracy from location other than nose boom which was not possible in conjunction with $\alpha - \beta$ vane. A further difficulty was the weather-cocking of a vane into a crosswind on the ground and at low air speeds. This prevented the vane being used in the low speed configuration. Accordingly the use of a yaw vane was abandoned in favor of side accelerometers in both the normal and emergency yaw systems.

There remains a fair amount of detail work to be done especially in the field of dynamic analysis in conjunction mainly with

- a. maximum rates of roll available
- b. g limiting
- c. rudder monitor (arrangement)

The scheduling functions have to be finally approved and mechanised and the whole system should be simulated and checked under different flight conditions. To achieve this a rather extensive analog computer set-up is required for which equipment was ordered but not yet delivered. A five and six degree of freedom simulation is necessary with as much as possible of real hardware fed to the computer. The following facilities will be used.



AVRO AIRCRAFT LIMITED
MALTON, ONTARIO

TECHNICAL DEPARTMENT

REPORT No. P/Stability/137

SHEET NO. 4

AIRCRAFT:

C-105

CONFIDENTIAL

PREPARED BY

DATE

S. Kwiatkowski

March 1957

CHECKED BY

DATE

INTRODUCTION (Continued)

a. Analog Computer

Delivery of the bulk of ordered equipment is expected during May 1957.

b. Cockpit Rig

This Rig should be delivered to the Stability and Control Section during March 1957 for preliminary testing. Further rig improvements will be necessary to complete the program and it is estimated that this work will be completed by December 1957.

c. Damping System Simulator

To be delivered in March 1957 by Minneapolis-Honeywell.

d. B-1 Rig

Flying controls of all three axes will be available for testing in Nov. - Dec. 1957.



AVRO AIRCRAFT LIMITED
MALTON - ONTARIO

TECHNICAL DEPARTMENT

REPORT No. P/Stability/137

SHEET No. 5

AIRCRAFT:

C-105

PREPARED BY

DATE

S. Kwiatkowski

March 1957

CHECKED BY

DATE

UNCLASSIFIED

2. GENERAL REQUIREMENTS

2.1 Normal Damping System

- 2.1.1 To damp short period oscillations about all three axes. To meet U.S.A.F. Spec. MIL 8785.
- 2.1.2 To damp longitudinal long period oscillations.
- 2.1.3 To provide spiral stability, such that rate of divergence is less than double amplitude in twenty seconds.
- 2.1.4 To provide stability augmentation in yaw such that 50% of the fin limit load is not exceeded.
- 2.1.5 To provide a means of manual emergency control compatible with the normal system in which flight commands are obtained from an electrical control stick or automatic modes.
- 2.1.6 To provide response to commands compatible with requirements of fire control.
- 2.1.7 To provide acceptable feel characteristics resulting in stick force per 'g' and stick force per unit of rate of roll essentially constant within the speed and altitude range, with exception of low speed.
- 2.1.8 To provide positional feel in all three axes in landing and take-off configuration.
- 2.1.9 To provide acceptable trimming characteristics.
- 2.1.10 To safeguard the aeroplane against manoeuvres resulting in prohibitive load factors. (normal acceleration, transverse acceleration, rate of roll).



AVRO AIRCRAFT LIMITED
MALTON - ONTARIO

TECHNICAL DEPARTMENT

REPORT No. P/Stability/137

SHEET No. 6

AIRCRAFT

C-105

UNCLCONFIDENTIAL

PREPARED BY

DATE

S. Kwiatkowski

March 1957

CHECKED BY

DATE

GENERAL REQUIREMENTS (Continued)

- 2.1.11 To minimize sideslip in manoeuvres (turn co-ordination).
- 2.1.12 To provide for uncoordinated manoeuvres at low speed (e.g. landing with sideslip).
- 2.1.13 To provide satisfactory feel characteristics in the yaw axis during sideslip at low speed.

2.2 Emergency Mode

- 2.2.1 Emergency mode to be complete duplication of the part of the normal system providing stability augmentation in yaw.
- 2.2.2 Emergency mode to provide items described under 2.1.4, 2.1.10, 2.1.11, 2.1.12.
- 2.2.3 Switching
- 2.2.4 Switching from one mode of operation to another should not result in sudden changes in the level of control forces in any axis.
- 2.2.5 Provisions to be made for automatic change-over from normal to emergency mode in case of failure of any component causing dangerous build-up of load factors.

AVRO AIRCRAFT LIMITED
MALTON ONTARIO

TECHNICAL DEPARTMENT

REPORT NO. P/Stability/137

SHEET NO. 7

AIRCRAFT:

C-105

PREPARED BY

DATE

S. Kwiatkowski

March 1957

CHECKED BY

DATE

UNCLASSIFIED
CONFIDENTIAL3. FUNCTIONAL DESCRIPTION - NORMAL DAMPER3.1 Pitch Axis

3.1.1 The block diagram of pitch axis is shown on Figure 1.

3.1.2 There are three basic inputs in the pitch axis, namely: (stick force) (electrical output of the stick force transducer), normal acceleration (from accelerometer located 22 ft. forward of c.g.) and pitch rate (from pitch rate gyro). Principle of operation is as follows: Stick force is compared with normal acceleration and the error signal drives parallel servo until both signals are equalized. This results in essentially constant stick force per 'g'. Pitch rate provides short period damping and normal acceleration phugoid damping. Suitable trimming units, switches and faders for low speed operation are provided. Also a 'g' limiter is included.

3.1.3 Pitch Rate

Pitch rate has a gain schedule based on compressible dynamic pressure (q_c) and is fed into the differential servos through a high pass filter while effective proportional signal is fed into the parallel servo. Such an arrangement avoids differential servo saturation under high steady state normal load factors, thus proper damping is assured under all conditions.

3.1.4 Normal acceleration and stick force error signal

This error signal is fed through a q_c gain schedule into the differential servo and also through another gain schedule (q_c and altitude) into the integrator in front of the parallel servo. This arrangement minimizes undesirable stick shaking in gusty air associated with normal acceleration feedback, while providing phugoid damping.



AVRO AIRCRAFT LIMITED
MALTON ONTARIO

TECHNICAL DEPARTMENT

REPORT NO. P/Stability/137

SHEET NO. 8

AIRCRAFT:

C-105

UNCONFIDENTIAL

PREPARED BY

DATE

S. Kwiatkowski

March 1957

CHECKED BY

DATE

FUNCTIONAL DESCRIPTION - NORMAL DAMPER (Continued)

3.1.5 Trimming Manual

With this arrangement, no trimming is necessary for level flight apart from minor corrections due to interference, stray voltages etc. To trim into a manoeuvre pilot's button operates a motor which introduces a signal into the comparator, and thus trims into any desired load factor.

3.1.6 Trimming - Automatic

In order to provide desirable feel effects in cases of failure of the normal damper the automatic trim is added. It operates as follows:

a. With pilot exerting force at the stick

Trim motor is actuated by the pressure pick-up in the parallel servo in such a manner that servo load is transmitted fully to the feel spring. Thus on disengagement of the parallel servo there is no change in stick force level. If stick force is released, aircraft will be out of trim and has to be retrimmed manually. This arrangement has an advantage in the fact that servo operates with small loads thus permitting optimum performance and also in case of main control valve tending to jam the trimmer spring helps to overpower the increased forces.

An interrupter is provided in the trimmer motor circuit to adapt it for continuous operations.

b. With no force on the stick:

Trim motor is actuated in the same manner as above but stops whenever an incremental .5 'g' is exceeded in any direction. Thus on disengagement aircraft returns to within 1/2 'g' of level flight. A separate accelerometer is utilized for this purpose.



AVRO AIRCRAFT LIMITED
MALTON ONTARIO

TECHNICAL DEPARTMENT

REPORT No. P/Stability/137

SHEET No. 9

AIRCRAFT:

C-105

PREPARED BY

DATE

S. Kwiatkowski

March 1957

CHECKED BY

DATE

CONFIDENTIAL
UNCLASSIFIED

FUNCTIONAL DESCRIPTION - NORMAL DAMPER (Continued)

3.1.7 Pressure Trim

Pressure trim is provided in the parallel servo to avoid engagement when pressures in the servo are not equalized. This assures smooth engagement free of undesirable stick movements.

3.1.8 Command Limits

The output of the stick force transducer is limited to a value adjustable between 4 and 6 'g'. It will be a fixed value on production aircraft. Also provisions were made to vary stick force per 'g' for development purposes.

3.1.9 'G' Limiting *

A 'g' limiter is provided to disengage the systems in case of malfunction of any of the components. It operates from two normal accelerometers (one forward and one aft of the c.g. of the aircraft) and elevator position pick-off. It is necessary to combine these signals in an amplifier rather than use a simple switch arrangement to obtain enough anticipation and assure proper functioning of the limiter under all flight conditions. This type of 'g' limiter was developed by M-H for another aeroplane and is being tailored to our specifications. Rudder monitor signal is also connected to the 'g' limiter to disengage the normal mode whenever rudder axis fails.

* For up to date description see Page 18c

The disengagement is obtained by a contact on the parallel servo which releases the pressure and another contact which recenters the differential servo. The differential servo has an additional sensor which permits immediate recentering only if it is going to reduce the resulting load factor, otherwise the differential servo is centered by normal damper action and then disengaged.



AVRO AIRCRAFT LIMITED
MALTON - ONTARIO

TECHNICAL DEPARTMENT

REPORT No. P/Stability/137

SHEET No. 10

AIRCRAFT:

C-105

PREPARED BY

DATE

S. Kwiatkowski

March 1957

CHECKED BY

DATE

CONFIDENTIAL

UNCLASSIFIED

FUNCTIONAL DESCRIPTION - NORMAL DAMPER (Continued)

3.1.10 Low Speed Operation

It is undesirable to maintain the constant stick force per 'g' characteristics at approach speed since this will result in over-sensitive control. A desired feature is a proportional feel. This is achieved by an arrangement of switches and faders which operate automatically with undercarriage selector switch. When undercarriage down is selected the system operates as follows:

Normal acceleration input into the differential servo is faded out and pitch rate proportional signal introduced through bypassing the high-pass filter. This provides good short period damping. Normal inputs into the parallel servo are cut-off and the proportional signal introduced into the junction box of the parallel servo by running up the fader in that line. Trimmer button is connected directly to the integrator (see block diagram).

Upon selection of undercarriage up, the system reverts to normal.

3.1.11 Pre-engage Switches

Pre-engage circuits are provided to energise the components and assure smooth engagement.



AVRO AIRCRAFT LIMITED
MALTON ONTARIO

TECHNICAL DEPARTMENT

REPORT NO. P/Stability/137

SHEET NO. 11

AIRCRAFT:

C-105

PREPARED BY

DATE

S. Kwiatkowski

March 1957

CHECKED BY

DATE

CONFIDENTIAL

UNCLASSIFIED

FUNCTIONAL DESCRIPTION - NORMAL DAMPER (Continued)

3.2 Roll Axis

3.2.1 Roll axis diagram is shown on Figure 2.

3.2.2 There are two basic inputs in the roll axis: stick force (electrical output of the stick force transducer) and roll rate (gyro output). Principle of operation is similar to pitch axis. Stick force is compared to roll rate and the error signal drives the servos. This results in essentially constant stick force per unit of rate of roll. Suitable trimming units and switches for low speed operation are included as well as a rate of roll limiter. In addition, for safety reasons, a command limiter scheduled on transverse acceleration is included.

3.2.3 Roll Rate and Stick Force Error Signal

This error signal is fed through a q_c gain schedule into both parallel and differential servos. This results in optimum conditions from the point of view of response to command signals and damping of the "dutch roll" mode.

3.2.4 Trimming - Manual

Manual trim is provided in the form of electrical input into the comparator, through a motor operated by the pilot's button.

Automatic trim is not included in the roll axis.

3.2.5 Pressure Trim

Pressure trim is provided - see 3.1.7.

AVRO AIRCRAFT LIMITED
MALTON ONTARIO

TECHNICAL DEPARTMENT

REPORT No. P/Stability/137

SHEET No. 12

AIRCRAFT:

C-105

PREPARED BY

DATE

S. Kwiatkowski

March 1957

CHECKED BY

DATE

UNCLASSIFIED
CONFIDENTIALFUNCTIONAL DESCRIPTION - NORMAL DAMPER (Continued)

3.2.6 Command Limits

Command limiter is provided in the stick force transducer at $120^\circ/\text{sec.}$ of roll rate. In addition, a limiter scheduled with transverse acceleration is present. This limits the command at some conditions to a value (below $120^\circ/\text{sec.}$) which will not result in excessive fin loads. It specifically applies at high dynamic pressures and at low supersonic speeds at high altitudes. At the latter conditions the limiter action will be noticed in rolls exceeding approx. 180° of roll angle, while up to this angle maximum rates of roll can be realised. Stick force per unit rate of roll is essentially constant so that maximum rate of roll ($120^\circ/\text{sec.}$) corresponds to full aileron force (20 lb.).

3.2.7 Roll Rate Limiter

Provides protection against system malfunction. Operates from wing tip mounted accelerometer, and has an input from rudder monitor to disengage normal mode when a failure occurs. Disengagement is achieved by disconnecting parallel servo and recentering of differential servos.

3.2.8 Low Speed Operation

In order to obtain proportional feel at low speed a set of switches is incorporated operating automatically with undercarriage selector switch. When undercarriage down is selected, the system operates as follows:

A proportional signal with constant gain K_p is introduced into the parallel servo and the integrator is disconnected. Error signal remains in the differential servos providing damping of the "dutch roll" mode.



AVRO AIRCRAFT LIMITED
MALTON, ONTARIO

TECHNICAL DEPARTMENT

AIRCRAFT

C-105

CONFIDENTIAL

REPORT No. P/Stability/137

SHEET No. 13

PREPARED BY

DATE

S. Kwiatkowski

March 1957

CHECKED BY

DATE

FUNCTIONAL DESCRIPTION - NORMAL DAMPER (Continued)

- 3.2.9 Provisions for symmetrical deflections of ailerons. Performance analysis shows that a considerable reduction in trim drag can be achieved by symmetrical deflection of ailerons at altitudes in excess of 45,000 ft. at supersonic speeds. This is achieved by splitting the quadrant through which commands are delivered to each aileron. The relationship of the two halves to the command system are then governed by a jack which is controlled by an altitude switch. This changes the neutral setting of the ailerons by the desired amount.



AVRO AIRCRAFT LIMITED
MALTON - ONTARIO

TECHNICAL DEPARTMENT

REPORT NO. P/Stability/137

SHEET NO. 14

AIRCRAFT:

C-105

CONFIDENTIAL

PREPARED BY

DATE

S. Kwiatkowski

March 1957

CHECKED BY

DATE

3.3 Yaw Axis

3.3.1 The block diagram of normal yaw axis is shown in the upper half of Figure 3.

3.3.2 There are four basic inputs in the normal yaw axis, namely: transverse acceleration (from accelerometer located approx. 13 ft. forward of aircraft c.g.) yaw rate (gyro output), aileron position (from aileron position pick-off) and the product of pitch rate and aileron position. The principle of operation is as follows:-

Transverse acceleration provides stability augmentation, yaw rate assists in damping of the dutch roll, high-passed aileron position controls sideslip in rolls entered from level flight, while the product of pitch rate and aileron position offsets inertial cross-coupling effects in rolling pull-outs. With such a system, uncoordinated manoeuvres are possible to a rather limited extent and, therefore, a switch was added to provide for intentional sideslipping at low speed. Rudder monitor provides automatic switch over to emergency loop in case of malfunction.

3.3.3 Yaw Rate

Yaw rate has a qc gain schedule and is fed into the differential servo through a high pass filter. It contributes to damping especially at high altitudes by causing the rudder to oppose yaw rates.

3.3.4 Aileron Position

Aileron position has a qc schedule and is fed into the differential servo through the same high pass filter, thus steady state aileron will not produce a signal in this channel. This is important since steady state aileron may be required in level flight to balance asymmetric moments.



AIRCRAFT

C-105

PREPARED BY

DATE

S. Kwiatkowski

March 1957

CHECKED BY

DATE

3.3.5 Transverse Acceleration

Accelerometer output has a q_c schedule and is fed directly into the summing point in front of the differential servo. Its effect is similar to that of a sideslip angle feedback in this that it will tend to minimize sideslip under all conditions. This can easily be demonstrated since the accelerometer registers total aerodynamic force acting on the airframe rather than acceleration. The main component of this force is sideforce due to sideslip angle. Therefore, sideslip minimization will be provided also under steady state conditions where transverse acceleration of the airframe is not present.

3.3.6 Product of pitch rate and aileron position.

The product of these two variables is obtained in the damper and fed through a q_c schedule into the rudder differential servo.

The inertial cross-coupling effects on low aspect ratio airplanes are such that weathercock stability in yaw is effectively reduced in proportion to the product of pitch and roll rates causing excessive build-up of sideslip in rolling pull-outs. To offset this effect the product of pitch rate and aileron angle was introduced. Aileron angle is used instead of the roll rate since more anticipation is obtained in this manner and it is more convenient for scheduling.

3.3.7 Trimming

Since there is no parallel servo in the rudder axis electrical trimming within the circuit is not required. Conventional trim provisions are incorporated within rudder feel unit.



AVRO AIRCRAFT LIMITED
MALTON - ONTARIO

TECHNICAL DEPARTMENT

REPORT NO. P/Stability/137

SHEET No. 16

AIRCRAFT:

PREPARED BY

DATE

S. Kwiatkowski

March 1957

CHECKED BY

DATE

CONFIDENTIAL

3.3.8 Rudder Monitor *

* For up to date description see Pages 18a and 18b

This unit provides protection against malfunction of the system by switching over to emergency whenever transverse acceleration or sideslip approaches structural integrity limits. This switching mechanism operates on all three axes, e.g. whenever normal mode in the rudder axis fails, the monitor will switch not only rudder axis to emergency but the remaining two as well. It has two inputs, namely: transverse acceleration and sideslip angle. When acceleration at the sensor approaches .4g (transverse), switching occurs. At low speeds, however, a small acceleration may correspond to a rather high sideslip angle. Since the aircraft has undesirable characteristics above angle of sideslip of approximately 12° - 14° , switching is provided whenever angle of sideslip exceeds 10° .

At present difficulties arise in finalizing the rudder monitor configuration, since all conditions will not be met by system described above. Certain modifications may be required.

3.3.9 Low Speed Operation

A switch operated by the undercarriage down selector introduces a configuration change which allows the pilot to sideslip intentionally, e.g. for crosswind landing. This is achieved by high-passing most of the transverse acceleration signal while a small part is fed directly. Such configuration results in well damped "dutch roll" mode while rudder moves in natural direction at high sideslip angles at low speed. Clean configuration exhibits a tendency for very small or opposite rudder angles required for landing in high crosswinds, producing a rather "unnatural" feel for the pilot. This condition is known to exist in similar configurations and did result in limitations of the landing speeds. The system described above produces an acceptable characteristic of rudder to sideslip angle ratio at low speeds.



AVRO AIRCRAFT LIMITED
MALTON ONTARIO

TECHNICAL DEPARTMENT

REPORT NO. P/Stability/137

SHEET NO. 17

AIRCRAFT:

C-105

CONFIDENTIAL
UNCLASSIFIED

PREPARED BY

DATE

S. Kwiatkowski

March 1957

CHECKED BY

DATE

4. FUNCTIONAL DESCRIPTION - EMERGENCY MODE

4.1 Pitch Axis

All servos and stick force transducer are disconnected hence there are no electrical signals with exception of trim unit. Mechanical connections are provided to the main control valves. Proportional feel is provided together with conventional trim unit. Command and g limiters are of course inoperative and therefore, responsibility for not exceeding structural integrity limits in normal load factors rests with the pilot. In some conditions the aircraft is protected, however, by virtue of hinge moment and elevator deflection limitations.

4.2 Roll Axis

All servos and stick force transducers are disconnected. Mechanical connections are provided to main control valves. Proportional feel is provided together with conventional trim unit. Limiters are inoperative and pilot is responsible for not exceeding structural integrity limits in rate of roll. Since transverse acceleration fader is not operating in emergency mode the pilot should restrict his roll rate commands, especially in rolls entered at high normal accelerations.

4.3 Yaw Axis - Emergency

4.3.1 The block diagram of emergency mode is shown in the lower half of Figure 3.

4.3.2 There are three basic inputs into the emergency mode namely: transverse acceleration, yaw rate and aileron position. For simplicity reasons the product of pitch rate and aileron position is not included. This restricts somewhat the rates of roll that can be applied in pull-outs.

4.3.3 Inputs into the emergency mode operate on the same principle as these in the normal mode. For reliability reasons separate sensors are used.



AVRO AIRCRAFT LIMITED
MALTON - ONTARIO

TECHNICAL DEPARTMENT

REPORT No. P/Stability/137

SHEET No. 18

AIRCRAFT:

C-105

PREPARED BY

DATE

S. Kwiatkowski

March 1957

CHECKED BY

DATE

UNCLASSIFIED
CONFIDENTIAL

4.3.4 Rudder Feel and Trim Unit

Pedal force per unit rudder deflection is scheduled vs q_c in order to restrict the rudder application by the pilot. At high speeds a small rudder deflection may cause a prohibitive vertical fin load, therefore high pedal forces are associated with small deflections, in high speed regime. Pilot authority as limited by his maximum pedal force (assumed at 150 lb.) corresponds to approximately one fifth to one third of the total jack output at high speeds, and to full rudder deflection at low speeds.

Trim authority is proportional to and somewhat higher than pilots authority at high speeds, while full rudder can be trimmed at low speeds. This arrangement permits un-coordination of sideslip to a rather limited extent at high speeds and is sufficient to cope with assymetric power and other moments throughout the speed range.

4.3.5 Low Speed Operation

Operation identical with normal mode, see 3.3.9.



10 AIRCRAFT LIMITED
MALTON - ONTARIO

TECHNICAL DEPARTMENT

REPORT No. P/Stability/137

SHEET No. 18b

AIRCRAFT:

C-105

PREPARED BY

DATE

S. Kwiatkowski

June 1957

CHECKED BY

DATE

UNCONFIDENTIAL
CLASSIFIED

3.3.8 Rudder Monitor (Continued)

Accelerometers alone will not produce desired functions at low speeds since a small acceleration may correspond to a rather high sideslip angle. Since the aircraft has undesirable characteristics above angle of sideslip of approx. 12-14° additional switch is provided whenever angle of sideslip exceeds 10°.



10 AIRCRAFT LIMITED
WALTON, ONTARIO

TECHNICAL DEPARTMENT

REPORT No. P/Stability/137

SHEET No. 18c

AIRCRAFT:

C-105

PREPARED BY

DATE

S. Kwiatkowski

June '57

CHECKED BY

DATE

CONFIDENTIAL

UNCLASSIFIED

3.1.9 "G" Limiter

A "g" limiter is provided to disengage the system in case of malfunction of any of the components. It operates from two accelerometers (one forward and one aft from the c.g. of the aircraft) and two servo positions pick-offs (parallel and differential). It is necessary to combine these signals in an amplifier through filtering networks to obtain enough anticipation and assure proper functioning of the limiter under all flight conditions. A differential servo pick-off was added to provide protection against differential servo failure which may produce unstable oscillations under some flight conditions. A separate pick-off is provided on each differential servo. Parallel servo pick-off protects against servo runaway type of failure.

The "g" limiter will automatically disengage the normal pitch axis at such level of normal acceleration that resulting overshoot will not exceed structural limits of the aircraft in all flight conditions. Rudder monitor signal is also connected to the "g" limiter to disengage the normal mode whenever rudder axis fail.

The disengagement is obtained by a contact on the parallel servo which releases the pressure and another contact which recenters the differential servo. The differential servo will recenter immediately only if this action is going to reduce the resulting load factor, otherwise the differential servo is centered by normal damper action and then disengaged.

When the disengagement is completed the aircraft will be in the emergency mode of control and then the pilot is responsible for not exceeding structural limits of the airframe.



AVRO AIRCRAFT LIMITED
MALTON - ONTARIO

TECHNICAL DEPARTMENT

REPORT No. P/Stability/137

SHEET No. 19

AIRCRAFT:

C-105

CONFIDENTIAL

PREPARED BY

DATE

S. Kwiatkowski

March 1957

CHECKED BY

DATE

5. STATUS OF WORK AS OF MARCH 1st 1957

5.1 Block Diagrams

System block diagrams are firmly established as described in Sections 3 & 4 with possible exception of rudder monitor.

5.2 Gain Schedules

Gain schedules will be finalized by end of March, 1957. M-H proposal on these was just received and generally approved but some minor points have yet to be mutually agreed upon.

5.3 Rudder Monitor

A modification may be necessary but configuration described herein could be used. This problem should finally be resolved by the end of March 1957.

5.4 Dynamic Analysis

5.4.1 High Speed

The system was finalized in accordance with accepted practice by simulation of pitch axis in its two and three degrees of freedom, and combined roll and yaw axis in its three degrees of freedom. Spot checks only were carried out with combined (coupled) five degrees of freedom equations and only a limited number of non-linearities was introduced due to limitations of present analog equipment. It will therefore, be necessary to systematically re-evaluate finalized system performance using full coupled equations with all non-linear terms at least with five degrees of freedom with spot checks with six (forward speed) and seven (altitude).

46 flight conditions were selected to cover flight envelopes and all will have to be checked. Such simulation will yield numerical data of system performance, limitations, restrictions (if any) etc. In addition effects of asymmetric power, wing twist, open canopy etc. will be evaluated accurately. This simulation will include certain new inputs, e.g. recently modified servo performance characteristics (not yet



AVRO AIRCRAFT LIMITED
MALTON - ONTARIO

TECHNICAL DEPARTMENT

REPORT No. P/Stability/137

SHEET No. 20

AIRCRAFT:

C-105

UNCLASSIFIED

PREPARED BY

DATE

S. Kwiatkowski

March 1957

CHECKED BY

DATE

5.4.1 delivered by M-H), aerodynamic derivative changes obtained from Free Flight Models (analysis not completed yet) etc. Data obtained in this manner could later be used as a basis of comparison with flight test results and will speed up flight test analysis if a sufficiently large number of flight conditions is analyzed now.

This program is being held up at the moment by late delivery of additional analog equipment (first batch should have been delivered on January 15th). This is a major program and will be carried out intermittently up to flight test time.

5.4.2 Low Speed

A separate low speed full simulation is required in order to establish handling characteristics. Cockpit rig will be utilized for this purpose. This program will start as soon as cockpit rig is delivered (March 1957).



AIRCRAFT

C-105

UNCLASSIFIED
CONFIDENTIAL

PREPARED BY

DATE

S. Kwiatkowski

June 1957

CHECKED BY

DATE

STATUS OF WORK AS OF JUNE 25th 1957

5.1 Block Diagrams

All System block diagrams are firmly established, including modifications to the "g" limiter described on page 18c.

5.2 Gain Schedules

All gain schedules are finalized and agreed upon.

5.3 Rudder Monitor

A new configuration has been agreed upon. Detail description is shown on pages 18a and 18b.

5.4 Dynamic Analysis

5.4.1 High Speed

Preparations are being made for all-speed and all altitude simulator program. Additional analog equipment has been delivered. Other equipment has been ordered and should be delivered in time for the program to start at the end of September 1957.

5.4.2 Low Speed

Low speed simulation is completed and will be reported separately.

5.5 Damping Systems Simulator

Phase I completed in part. Further modifications are necessary to bring up to date the simulator configuration, to be compatible with the finalized version of the damper.



AVRO AIRCRAFT LIMITED
MALTON ONTARIO

TECHNICAL DEPARTMENT

REPORT NO. P/Stability/137

SHEET No. 21 1

AIRCRAFT:

C-105

CONFIDENTIAL

PREPARED BY

DATE

S. Kwiatkowski

March 1957

CHECKED BY

DATE

6. TEST PROGRAM

The test program will involve:-

6.1 Cockpit Rig

To provide answers to problems connected with feel and handling characteristics.

To familiarize the test pilots with the behaviour of the airplane.

To establish flyability regions under emergency conditions (clean airframe).

To develop instrumentation for production airplanes.

Development of full instrumentation to be incorporated in the cockpit rig will take approx. 6 months. Parallel servos have to be installed (not available yet), and hydraulic power source has to be provided. Installation of the rig for preliminary testing is held up because new laboratory area is not ready.

6.2 Damping System Simulator

To be delivered by M-H in March 1957. The rig is in fact a damper which is not flight worthy on which development work can be carried out in conjunction with analog computer, cockpit rig and B-1 rig. Since the design of this item had to be frozen some time before the damping system was finalized, it will require some modifications to bring it up to date. These tests will be mainly concerned with assessment of electrical hardware in the damping system. Performance characteristics of each item will be evaluated and its effect on the whole system and eventual modification suggested. Finally this simulator will be integrated with the cockpit rig and the B-1 rig in order to functionally prove the behaviour of the whole damping system including servos, control surfaces etc. Program of tests is described in Appendix A and B. At present a difficulty is experienced in providing on time a sufficient number of demodulation channels.



AVRO AIRCRAFT LIMITED
MALTON, ONTARIO

TECHNICAL DEPARTMENT

REPORT NO. P/Stability/137

SHEET NO. 22

AIRCRAFT:

C-105

CONFIDENTIAL

PREPARED BY

DATE

S. Kwiatkowski

March 1957

CHECKED BY

DATE

6.2 Damping System Simulator Cont'd.

Servo monitor equipment of the type required only recently appeared on the market and earlier delivery could not be obtained. Therefore, only a limited amount of testing can be carried out prior to May 1st, 1957.

6.3 B-1 Rig

B-1 Rig shall be required for tests of the damping system subject to other programs that are being carried out on it. It will be necessary to make runs in each of the three axis separately as soon as they become available. The combined three axis runs should be made during November - December 1957. The type of test required is described in Appendix C.

6.4 Flight Test

Flight test program and associated ground tests are under discussions now and will be issued in due course.



AVRO AIRCRAFT LIMITED
MALTON - ONTARIO

TECHNICAL DEPARTMENT

REPORT NO. P/Stability/137

SHEET No. 23

AIRCRAFT:

C-105

PREPARED BY

DATE

S. Kwiatkowski

March 1957

CHECKED BY

DATE

UNCONFIDENTIAL
UNCLASSIFIED

7. ASSOCIATED PROGRAMS

7.1 Aircraft 18107

Development of the fully powered control system on CF-100 aircraft was undertaken in order to obtain practical experience of this type of system. First part of the program consisted of development of control valves with suitable force characteristics. Difficulties were experienced in minimizing the forces appearing at the main control valve. Eventually a suitable configuration was developed, this was an important contribution to the development of the C-105 emergency mode.

Second part of the program consisted of development of a control stick steering mode utilizing the principle of normal acceleration feedback, similar to the C-105 system. Practical experience of such systems is necessary to obtain information on system behaviour from the point of view of trimming characteristics, threshold of components, dynamic performance etc. The system has been designed and manufactured and a series of tests remains to be done prior to flight test expected to take place in April 1957

Design difficulties experienced up to date were:-

- a) demodulator equipment
- b) lead lag network
- c) noise in electronic circuits

7.2 Autopilot

Although responsibility for autopilot design rests entirely with M-H, some work will be required at Avro to establish compatibility with the damping system. The autopilot system should be simulated and checked for stability and performance in order to assure full utilization of airframe capabilities. At present not enough information is available to proceed with this program.



AVRO AIRCRAFT LIMITED
MALTON ONTARIO

TECHNICAL DEPARTMENT

REPORT No P/Stability/137

SHEET No 24

AIRCRAFT:

C-105

PREPARED BY

DATE

S. Kwiatkowski

March 1957

CHECKED BY

DATE

UNCLASSIFIED
CONFIDENTIAL

7.3 Fire Control System

As in the case of autopilot compatibility with damping system has to be established. Studies of tactical manoeuvres will indicate the best methods of attack and break-away to achieve the best possible use of the airframe. On this basis fire control system can be mechanized. Additional studies of weapons available will be necessary.

A limited amount of tactical studies have been made up to date. This is a long range program and has to be carried out in parallel with R.C.A. work in this field. The scope of the program will be expanded when more information is available.



AVRO AIRCRAFT LIMITED
MALTON - ONTARIO

TECHNICAL DEPARTMENT

REPORT NO. P/Stability/137

SHEET NO. 25

AIRCRAFT

C-105

PREPARED BY

DATE

S. Kwiatkowski

March 1957

CHECKED BY

DATE

UNCLASSIFIED
CONFIDENTIAL

8. APPENDIX

A. Damper Simulator Program

C. A note on B-1 Rig Tests

APPENDIX A

Avro Aircraft Limited

CONFIDENTIAL

INTER-DEPARTMENTAL MEMORANDUM

Reference Number: 5702/02E/J

Date 21st, February 1957
To Mr. J.A. Chamberlin
From S. Kwiatkowski
Subject DAMPER SIMULATOR PROGRAM

The following is a general lay-out of test program for damper simulator. Details of each phase will be specified by Stability and Control Section at a later date.

Phase I - Functional Check

To assess the operation and performance characteristics of damper alone.

Procedure: D.C. inputs to be introduced into converter servos in each channel and inputs into the servo amplifiers recorded. Frequency response to be measured where required. If in any channel significant performance deterioration appears each component in turn will have to be examined for frequency response, threshold, hysteresis etc. Performance of converters and demodulators to be checked.

Simulator to be modified to conform with final block diagram of the damping system.

Phase II - Integration with Analog Computer

Damper Simulator to be connected to the analog computer representing five degree of freedom of the aircraft. Outputs of the damper simulator are to be demodulated and fed into the simulated servos on the computers. Performance at several flight conditions to be checked against previously obtained results.

Phase III - Tests with Cockpit Rig

The command signals into the damper simulator to be obtained from stick force transducers in the cockpit rig. Parallel servos in the cockpit to be driven by the damper simulator. Differential servos and five degree of freedom aerodynamics to be simulated by the computer. Schematic block diagrams is shown on Fig. 1.

UNCLASSIFIED
CONFIDENTIALPhase IV - Test With B-1 Rig

The command signals into the damper simulator to be obtained from stick force transducer in the cockpit rig. All servos on B-1 to be driven by damper simulator. Analog computer to simulate five degree of freedom aerodynamics. Schematic arrangement is shown on Fig. 2.

The specific program concerning B-1 rig will be established by Stability and Control Section at a later date. It will be required to run tests with each of the three control axes separately, as soon as they are available.

SK/g

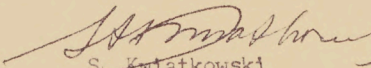

S. Kwiatkowski
Chief of Stability and Control

c.c. Messrs. W. Raymond
R. Carley
W. Taylor
J. Fennell
F. Brame
C. Marshall
J. Lynch

AIRCRAFT

C-105

PREPARED BY

DATE

S. Kwiatkowski

March 1957

CHECKED BY

DATE

UNCLASSIFIED
 CONFIDENTIAL

DAMPER SIMULATOR AND COCKPIT RIG TESTS

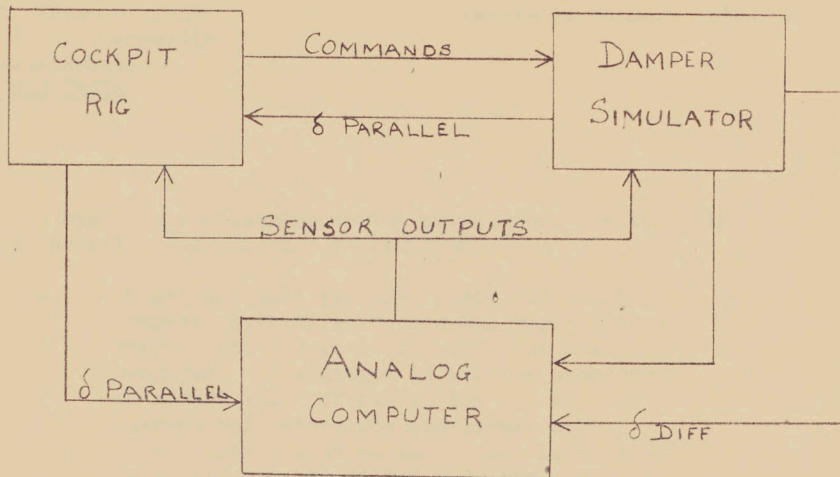

FIG. 1

B-1 RIG, COCKPIT RIG AND DAMPER SIMULATOR TEST

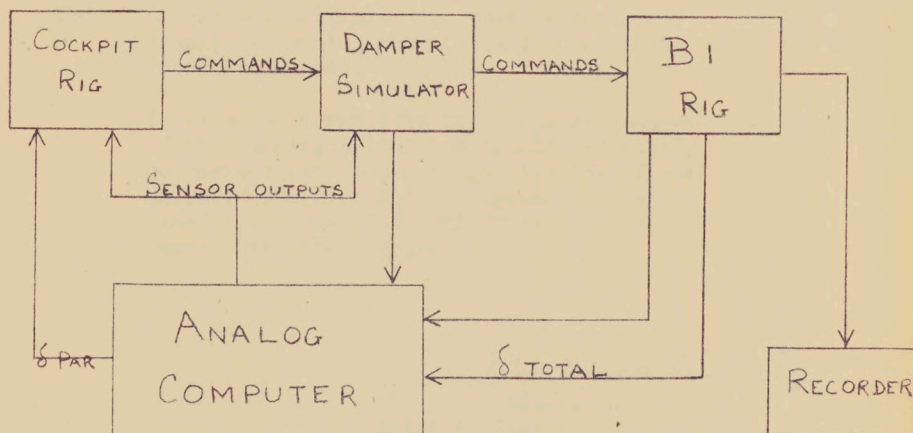

FIG. 2

APPENDIX C

Avro Aircraft Limited

INTER-DEPARTMENTAL MEMORANDUM

UNCONFIDENTIAL
CLASSIFIED

Date 21st, February 1957
To Mr. J. A. Chamberlin
From S. Kwiatkowski
Subject B-1 RIG TESTS

Reference Number: 5720/02E/J

To evaluate the damping system performance the following tests involving B-1 rig will be required.

- (a) Single and multiple axis tests with analog computer driving servos on B-1 rig. Control deflections are to be fed into the analog computer. In addition it will be necessary to record some outputs at the rig such as surface velocities and accelerations. Other signals such as individual servo outputs will have to be fed into the computer as required.

In this type of test some difficulties may arise since the rig operates on A.C. power.- Details of hook-up to be discussed with personnel in Stability and Control Section.

- (b) Single and multiple axis tests with damper simulator, analog computer and cockpit rig (where required).

These tests constitute the final assessment of the damping system and should definitely be carried out before flight testing of the damper. The proposed arrangement is outlined in my memo Ref 5702/02E/J on the Damper Simulator Program.

SK/g

S. Kwiatkowski
Chief of Stability and Control

cc Messrs W. Raymond
F. Brame
J. Ames
J. Lynch
S. Harper
J. Fennell

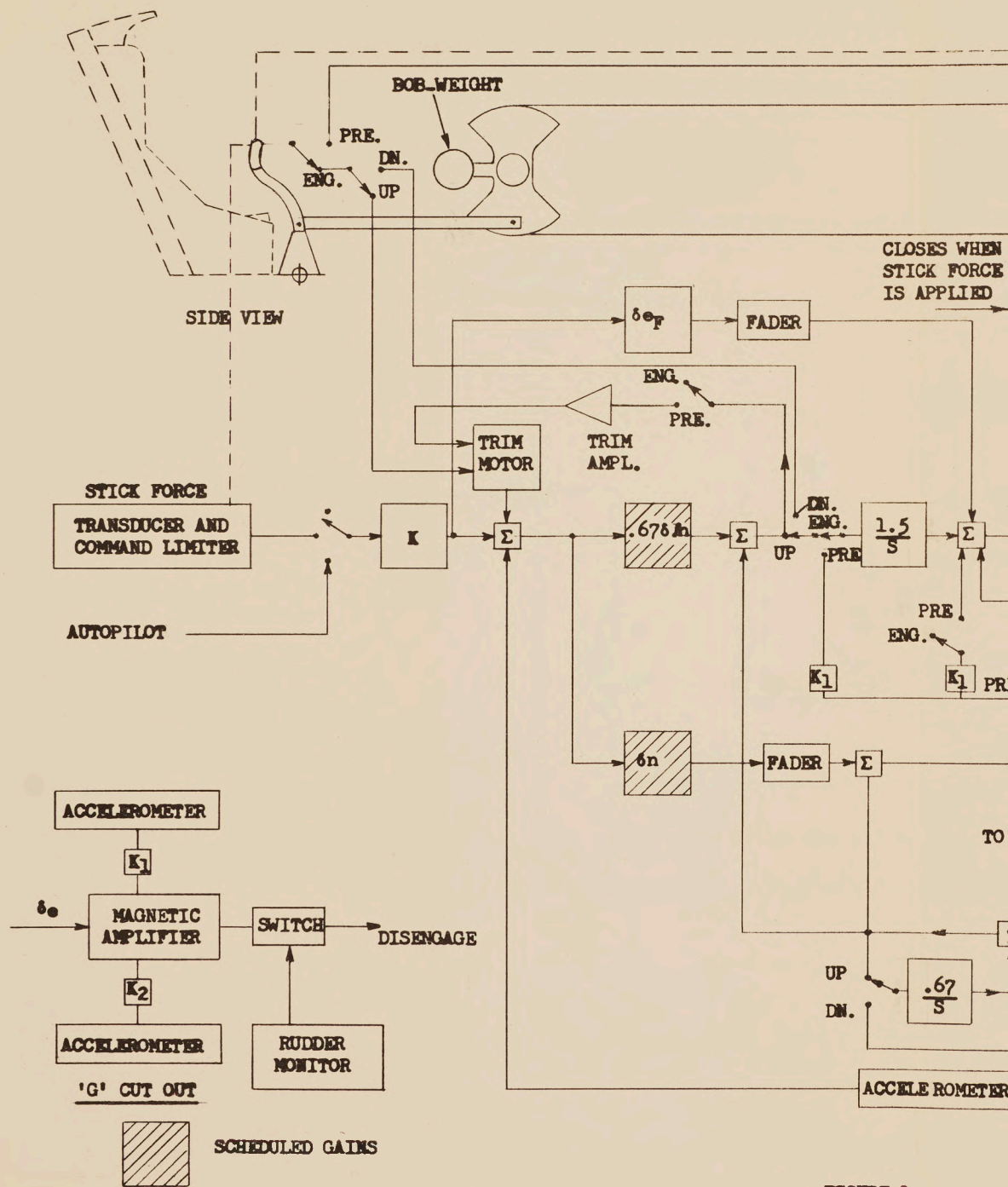

FIGURE 1

CF-105 PITCH DAMPER

UNCLASSIFIED
CONFIDENTIAL

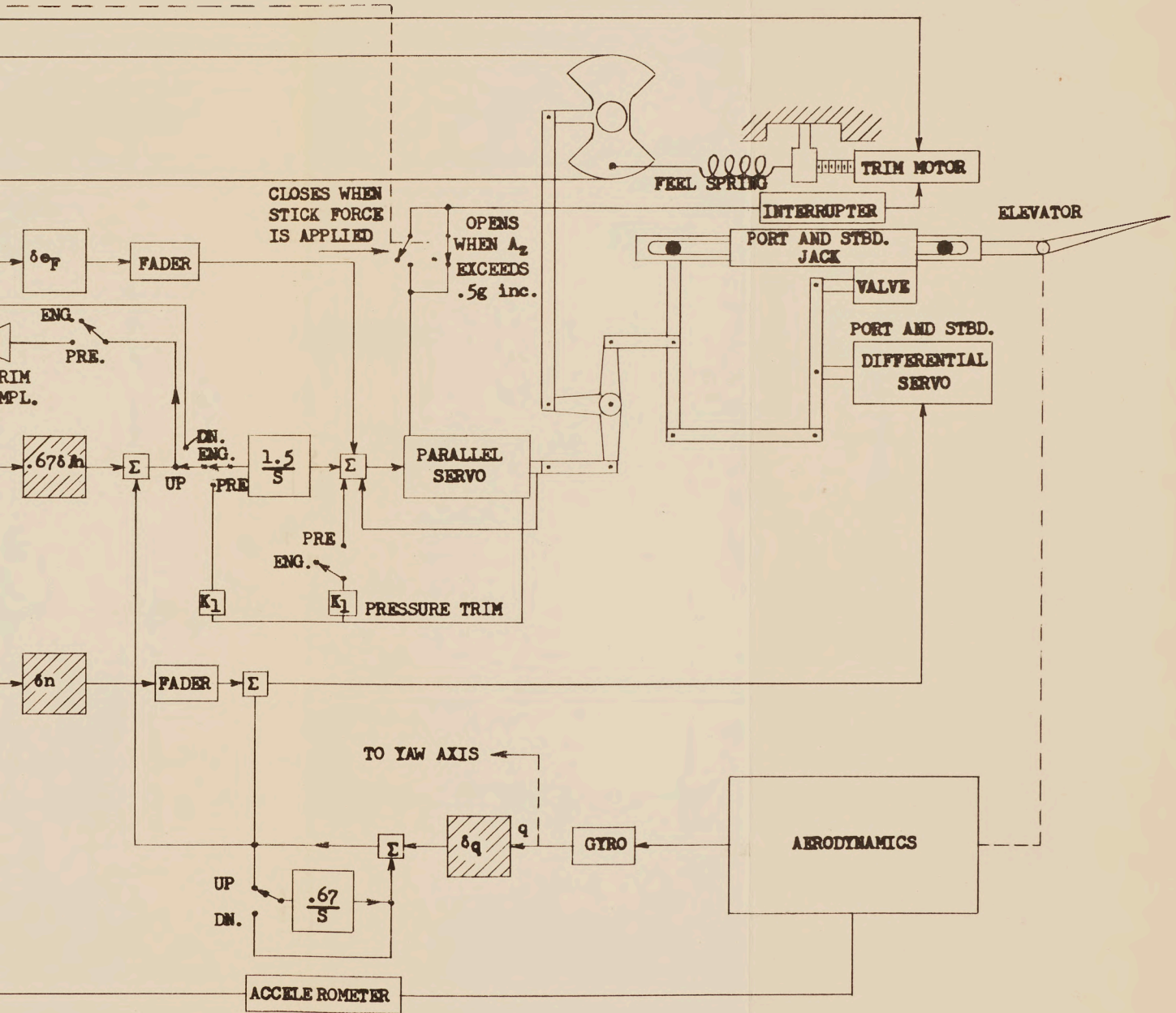

FIGURE 1

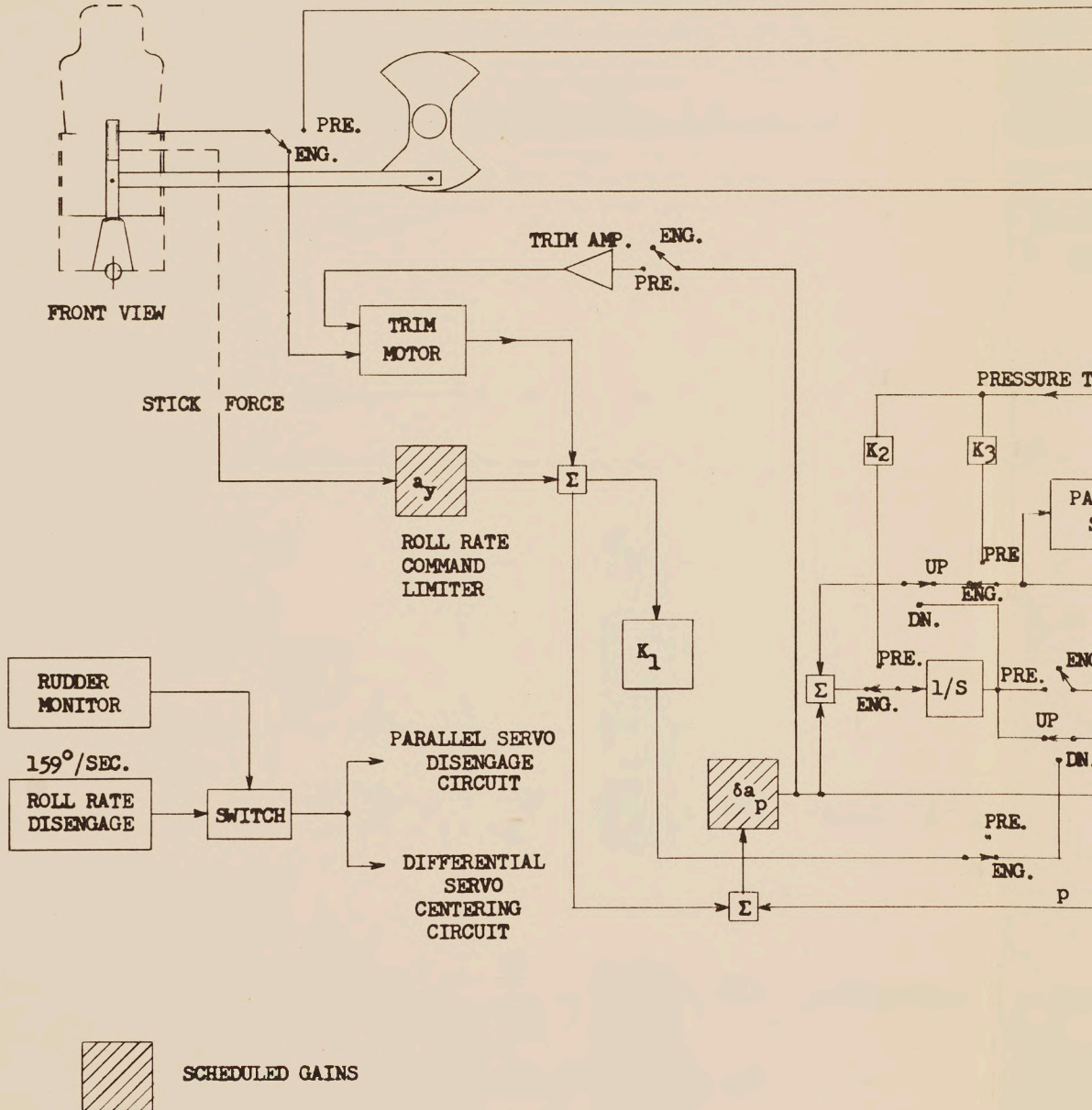

FIGURE 2

CF-105 ROLL DAMPER

UNCONFIDENTIAL

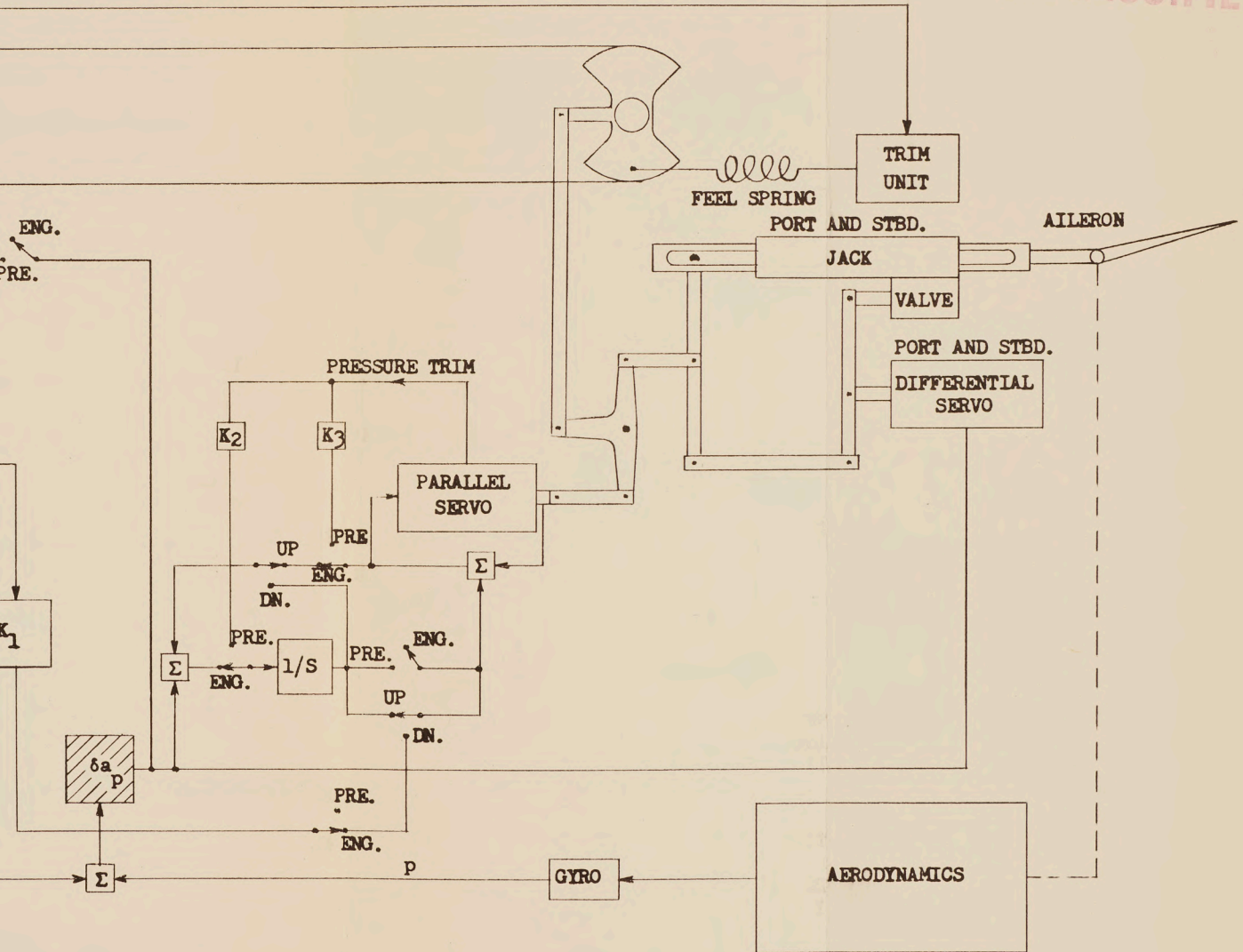

FIGURE 2

CF-105 YAW DAMPER

FROM PILOT'S
RUDDER TRIM
BUTTON

TOP VIEW



SCHEDULED GAINS

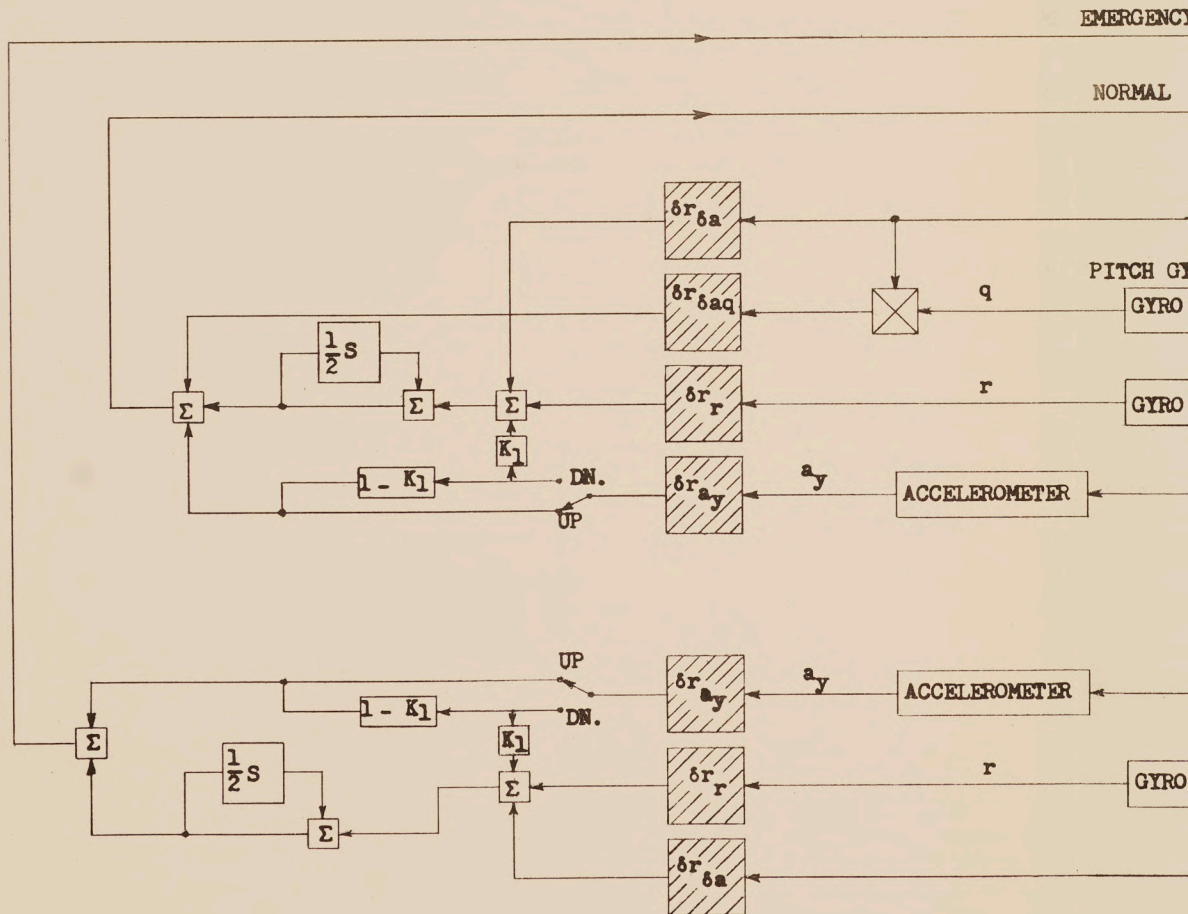

FIGURE 3

CF-105 YAW DAMPER

UNCLASSIFIED

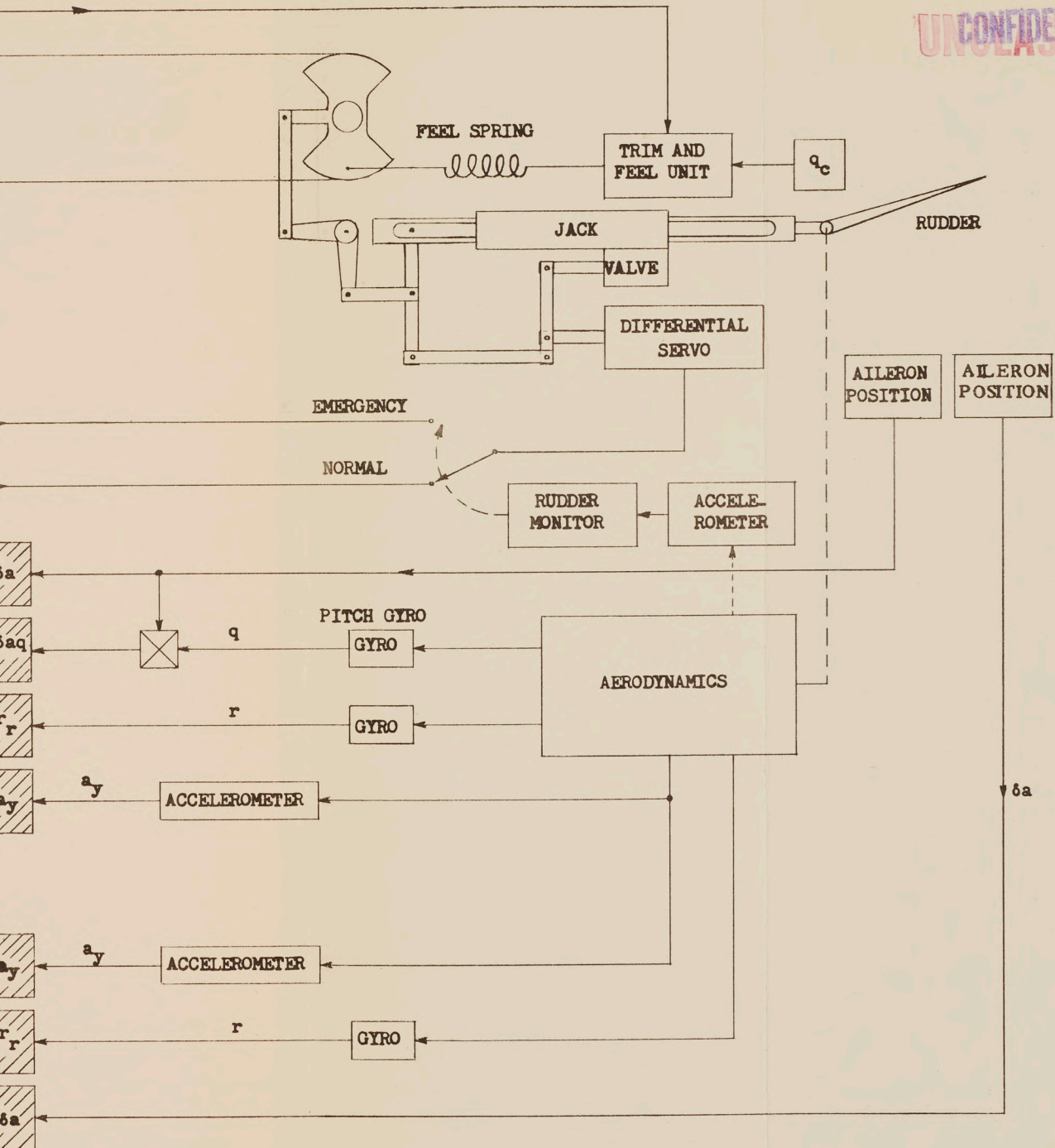
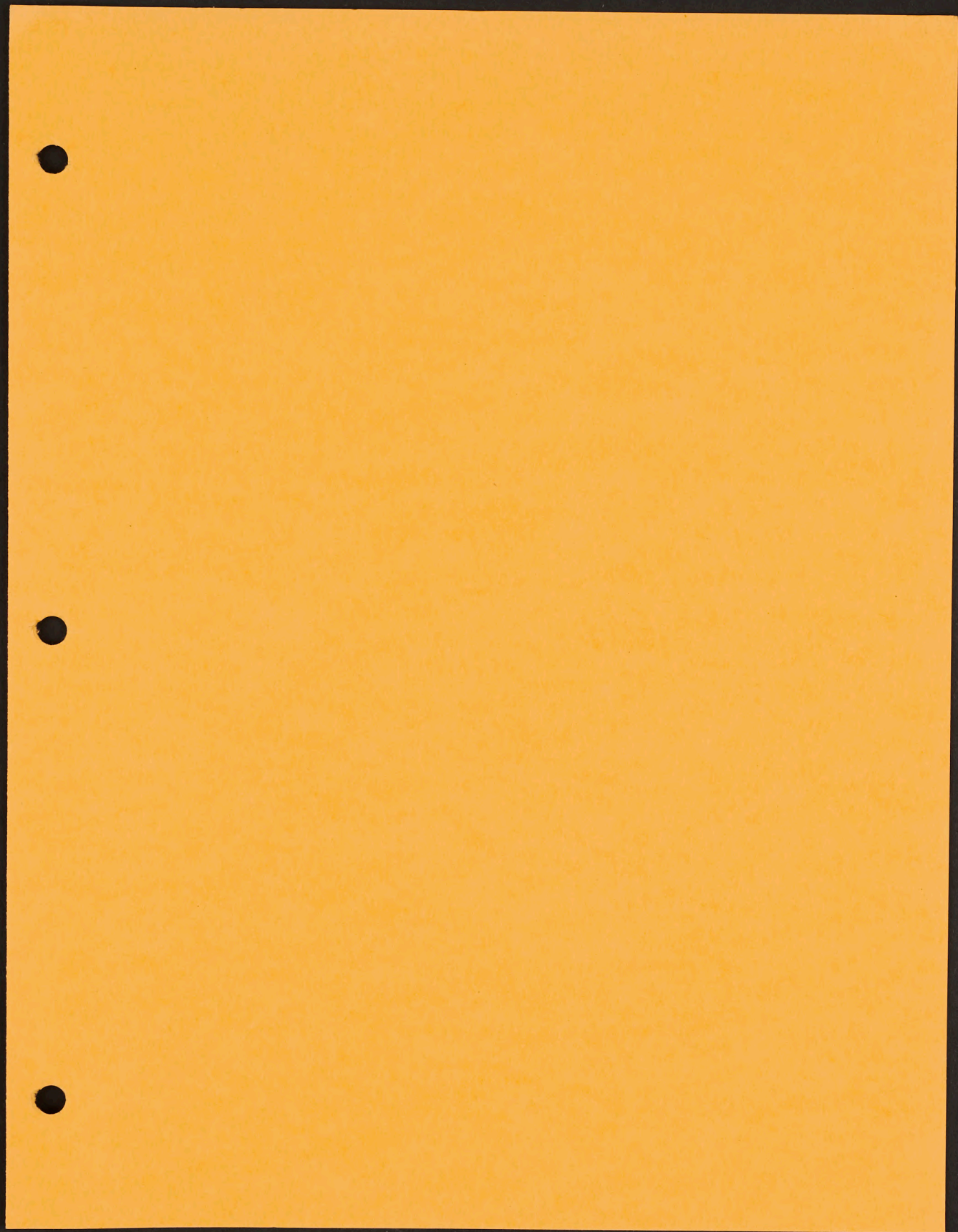

FIGURE 3



WILSON
JAN 1968
MADE IN U.S.A.