

QCX
Avro
CF105
70-MAINT
13/1
C2

OCTOBER 1957

UNCLASSIFIED
SECRET

**MAINTENANCE INSTRUCTION
ARROW DAMPER SYSTEM**

REPORT NO 70/MAINT 13/1

ENGINEERING DIVISION

UNLIMITED



AVRO AIRCRAFT LIMITED

FILE IN VAULT

NRC - CISTI
J. H. PARKIN
BRANCH

MAY 11 1995

ANNEXE
J. H. PARKIN
CNRC - ICIST



SECURITY CLASSIFICATION

UNCLASSIFIED

ARROW

MAINTENANCE INSTRUCTIONS

UNLIMITED

This report has been prepared to provide the necessary instructions and information to the maintenance personnel who are responsible for the correct and safe operation of the aircraft. The information contained herein, unless otherwise stated, is intended to be used as a guide only and does not constitute a contract. It is intended to maintain the project in the development phase and to be updated as necessary during the development process.

DAMPER SYSTEM

70 MAINT 13/1

21 Oct. 57

Prepared: *J. Gunnison*
For Maintenance and Reliability
Section

Approved: *G. R. Marshall*
For Technical Design Department

Approved: *[Signature]*
For Equipment Design Department

Authorized: *[Signature]*
Project Designer

UNCLASSIFIED

UNCLASSIFIED



National Research Council Canada Conseil national de recherches Canada

Canada Institute for Scientific and Technical Information
J.H. Parkin Branch

Institut canadien de l'information scientifique et technique
Annexe J.H.Perkin

Report No.: QCX Auro CF105 70-maint 13-1

Has been: Downgraded to: As per letter 1463 (AC) 95-0043

De-Classified

By: (Name)

(Dept)

Date: JAN 6 1966

B.J. Petzinger
Deputy Coordinator
Access to Information and Privacy

Signature



UNCLASSIFIED
SECRET

70/MAINT 13/1

UNLIMITED

FOREWORD

This report has been prepared to provide information regarding description and maintenance of the Arrow Damper System. It is intended that the report shall serve as an indoctrination document for persons concerned with this system.

The information contained herein, reflects maintenance design objectives as of the date of publication. It must be recognized that the Damper System is presently in the development phase and that significant changes may occur before the system is delivered to the field. It is intended to maintain the report as an effective document by revising as the development program continues and as more information becomes available.

It should be noted that the Automatic Flight Control, Automatic Ground Control Interception and Automatic Ground Control Approach Sub-system will not be installed in the Arrow I aircraft, although the tie-in between the Damper System and the above mentioned sub-system is covered in this report.



UNCLASSIFIED
SECRET

70/MAINT 13/1

TABLE OF CONTENTS

<u>Chapter</u>	<u>Para.</u>	<u>Subject</u>	<u>Page</u>
1		INTRODUCTION	1
2		DESCRIPTION	1
3		OPERATION	3
	3.1	Pitch Axis	3
	3.2	Roll Axis	12
	3.3	Yaw Axis	19
4		GROUND TEST EQUIPMENT	24
	4.1	Introduction	24
	4.2	Damper Test Set	25
	4.3	Damper Auxiliary Test Set	30
	4.4	Pitot - Static Test Set	32
	4.5	"G" Limiter Test Set	33
	4.6	Damper Test Stand	34
	4.7	Rate Table	36
5		FIRST LINE TESTING	37
	5.1	Test Equipment Required	37
	5.2	Preparation for Test	37
	5.3	Test Procedures	37
	5.4	Location of Faulty Components	47
6		SECOND LINE TESTING	62
	6.1	Damper Test Stand	62
	6.2	Rate Table	67
APPENDIX I		Damper and Associated Equipment List	70



SECRET

70/MAINT 13/1

LIST OF ILLUSTRATIONS

- FIGURE I Damper and Associated Equipment Location
- FIGURE 2 MH-64 Damper, Pitch Axis, Pre-engage, Gear Up or Down
- FIGURE 3 MH-64 Damper, Pitch Axis, Engage, Gear Down
- FIGURE 4 MH-64 Damper, Pitch Axis, Engage, Gear Up
- FIGURE 5 MH-64 Damper, Pitch Axis, (complete) Shown with Relay in Engage and Gear Up
- FIGURE 6 MH-64 Damper, Roll Axis, Pre-engage, Gear Up or Down
- FIGURE 7 MH-64 Damper, Roll Axis, Engage, Gear Down
- FIGURE 8 MH-64 Damper, Roll Axis, Engage, Gear Up
- FIGURE 9 MH-64 Damper, Roll Axis, (complete) Shown with Relay In Engage and Gear Up
- FIGURE 10 MH-64 Damper, Yaw Axis
- FIGURE 11 UG 6004A-1 Damper Test Set
- FIGURE 12 UG 6005A-1 Damper Auxiliary Test Set
- FIGURE 13 MB-1 Pitot-Static Test Set
- FIGURE 14 UG 6003A-1 Damper Test Stand
- FIGURE 15 UG 6002A-1 Rate Table
- FIGURE 16 Connection of Test Equipment to Aircraft



SECRET

70/MAINT 13/1

1. INTRODUCTION

- 1.1 Movement of the aircraft's ailerons, elevators and rudder is effected by hydraulic components which are normally controlled by electrical means. There is no provision for direct mechanical control. In the interests of safety, two independent flying control hydraulic systems are fitted.
- 1.2 There are three modes of control, the normal mode, the automatic flight mode, and the emergency mode.
- 1.3 In the normal mode, a damping system automatically stabilizes the aircraft in all three axes, and also co-ordinates rudder movement with movement of the ailerons and elevators. Control of the ailerons and elevators in this mode is by an electrical force transducer fitted in the control column.
- 1.4 In the automatic flight mode, the damping system is operative in the normal mode, but aileron and elevator position is controlled by an Automatic Flight Control Sub-system (AFCS). The AFCS allows the aircraft to be controlled from the ground for Automatic Ground Control Interception (AGCI) or for Automatic Ground Control Approach (AGGA). It also provides certain pilot assist functions by holding attitude, any set course and altitude or it may hold a set Mach number by varying the aircraft's pitch attitude. The AFCS also provides for automatic navigation by controlling the aircraft according to information fed into a dead reckoning computer by the navigator.
- 1.5 In the emergency mode, the hydraulic components for the ailerons and elevators are controlled mechanically. Yaw stabilization and rudder co-ordination are maintained by an emergency yaw damping system.
- 1.6 Pilot "feel" at the control column is provided by the damping system in the normal mode, and by mechanical means in the emergency mode.
- 1.7 A four-way push button on the control column allows for aileron and elevator trim. There are no trimmer tabs, trim being achieved by altering the position of the entire control surfaces. To reduce elevator trim drag at high altitudes, provision is made for an automatic up deflection of both ailerons.
- 1.8 If certain flight limitations are exceeded, the system automatically changes over to the emergency mode.

2. DESCRIPTION

- 2.1 Four distinct channels comprise the damping system; the pitch channel, which controls the elevators; the roll channel, which controls the ailerons; and the normal and emergency yaw channels, which control the rudder.



SECRET

70/MAINT 13/1

- 2.2 The switching controls for the damper system are located on a function selector panel fitted in the front cockpit LH console, and on the control column. Mounted on the function selector control panel are a POWER ON-OFF switch protected by a guard, an ENGAGE push switch for the normal mode and an EMERGENCY push-switch for engaging the emergency mode. Note that when the POWER ON-OFF switch is selected on, power is supplied to but does not engage the damper system and the AFCS. In addition, the normal mode of operation must be selected before the emergency mode of operation can be selected. Two push-switches are fitted in the control column handgrip. One switch, when operated, reverts the damper system to the emergency mode of operation, and the other switch when operated, disengages the AFCS but leaves the damper engaged. Three indicator lights fitted on the master warning system panel indicate, respectively, roll and/or pitch axis disengaged, emergency yaw damping system operative and all damping inoperative.

2756-105-1

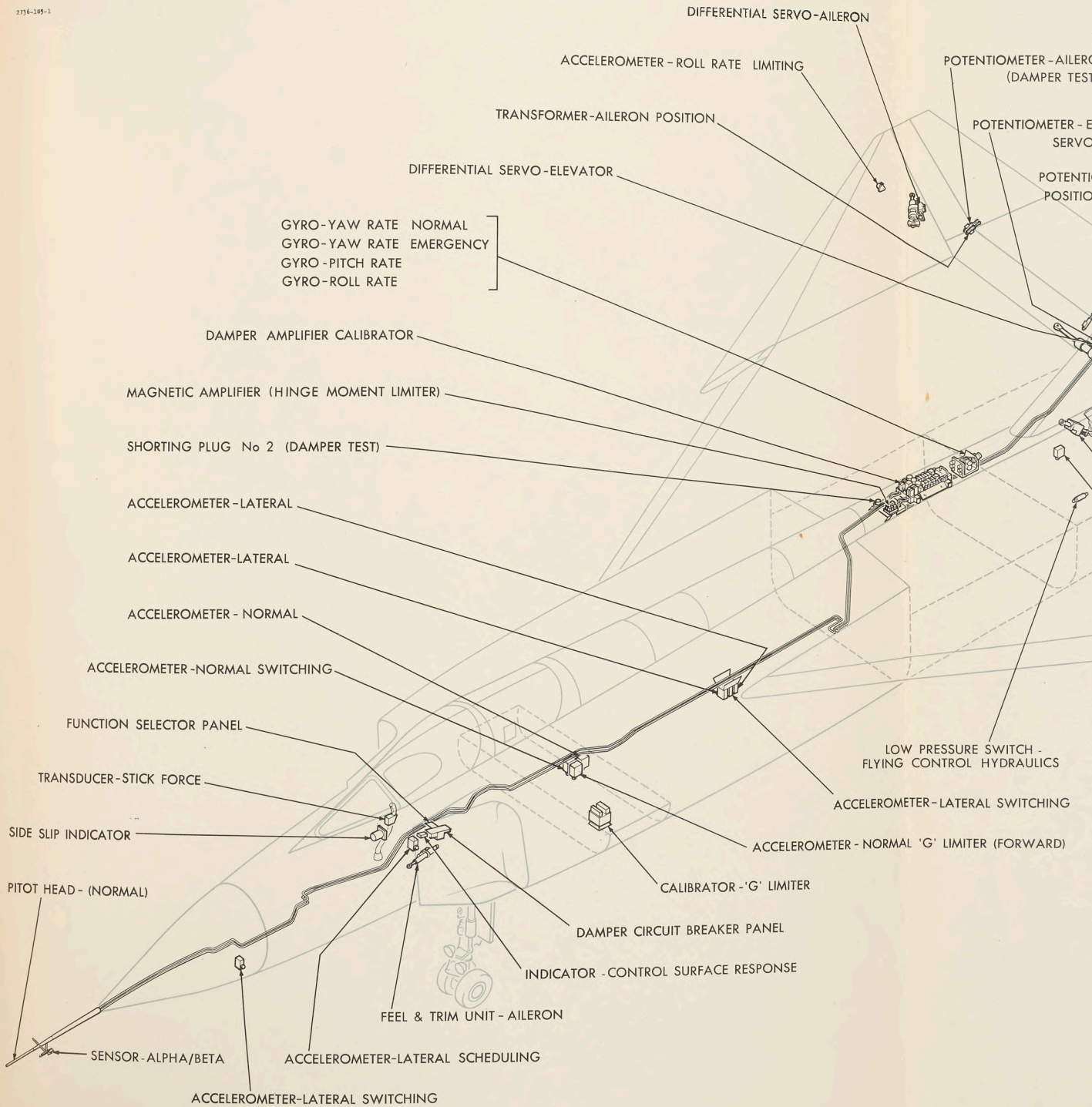

FIG. 1 DAMPER AND ASSOCIATED EQUIPMENT LOCATION

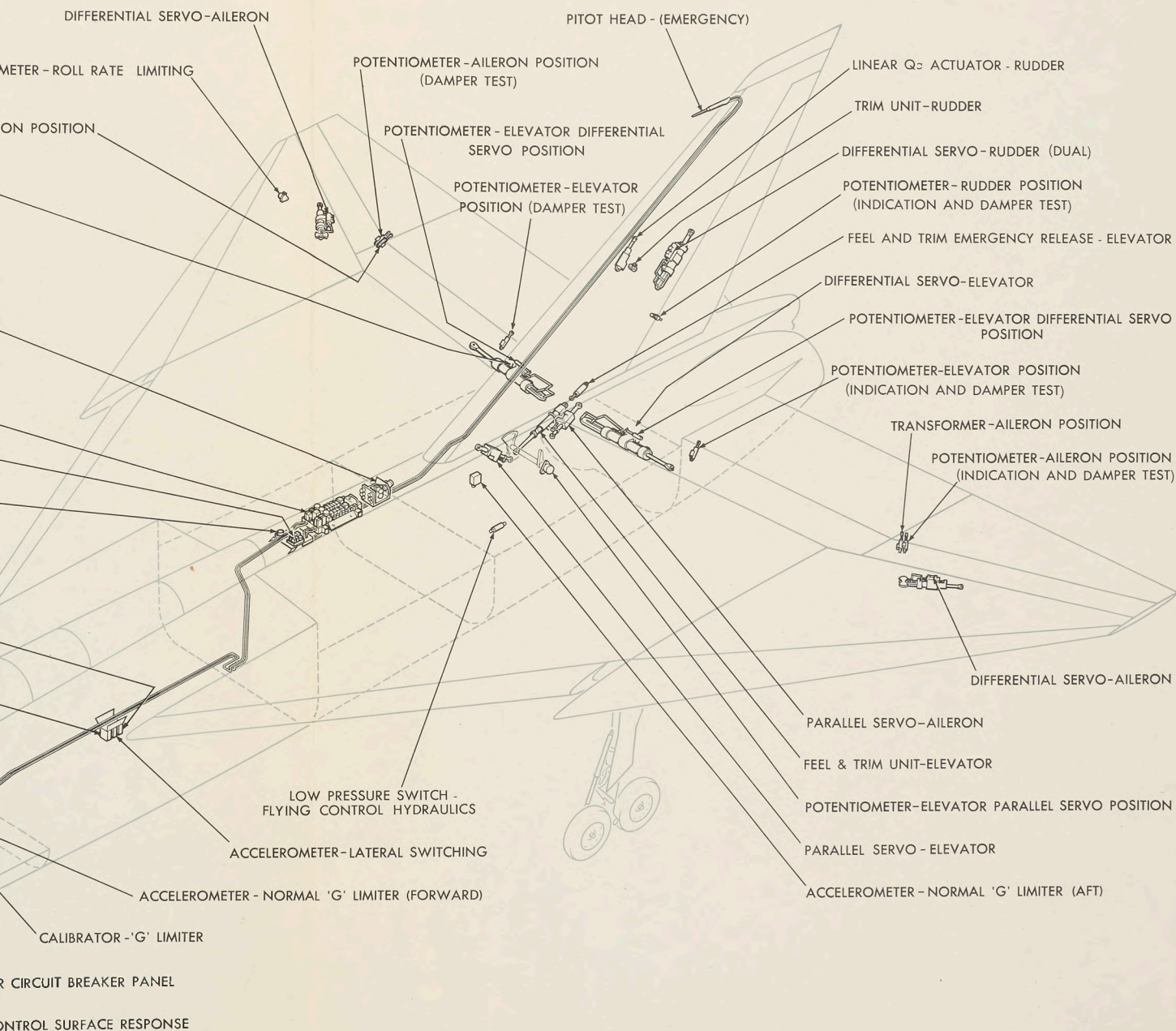

FIG. 1 DAMPER AND ASSOCIATED EQUIPMENT LOCATION



3. OPERATION

3.1 Pitch Axis (Figures 2,3,4 and 5)

Command Circuits

- 3.1.1 The pitch axis command circuits operate in response to command signals from the control column force transducer in the normal mode of operation or from the automatic flight control sub-system (AFCS) in the automatic mode of operation. On receiving such signals the command circuits actuate an electro-hydraulic parallel servo unit and two electro-hydraulic differential servo units and these in turn effect the appropriate positioning of the elevators. The operation of the command circuits is described in the following paragraphs.
- 3.1.2 Force exerted on the control column handgrip results in an output voltage from the force transducer which is fitted in the control column at the base of the handgrip. The magnitude of this voltage is directly proportional to the force exerted on the control column. The phasing of the voltage depends upon the direction of the motivating force relative to the neutral position of the control column, voltages produced by motion forward being 180° out of phase with voltages produced by motion aft. Note that changes in attitude are not commanded by movement of the control column but by the application of force on the handgrip which deflects the core of the force transducer. Movement of the control column, in effect, follows the positioning of the elevators by the command circuits, but the response of the system is so immediate that attitude changes appear to result from movement of the control column.
- 3.1.3 The output voltage from the transducer is approximately one volt for each six pounds of force exerted on the control column handgrip. The output of the transducer is restricted by means of adjustable mechanical stops which limit the maximum output from the amplifier to 6 volts.
- 3.1.4 The output from the transducer amplifier is supplied via a summing network as a command signal to an integrator unit the output voltage of which increases at a rate proportional to the strength of the command signal. The rate of increase of the integrator output is such as to prevent excessive rate of control surface movement. The integrator maintains its output even after the command signal is withdrawn, and until it is provided with a signal of opposite phase to reduce, cancel or reverse the output according to the strength of the new signal.



SECRET

70/MAINT 13/1

- 3.1.5 The output of the integrator is supplied through a summing network to a servo amplifier unit which amplifies the signal and determines its phase by means of a discriminator circuit.
- 3.1.6 From the servo amplifier the signal passes to the transfer valve of an electro-hydraulic parallel servo which controls the elevator movement in magnitude and direction in accordance with the strength and phase of the input signal. The parallel servo effects movement of the elevators via the elevator quadrant, and so a sympathetic movement of the control column takes place.
- 3.1.7 A self-balancing circuit is introduced from the parallel servo to the servo amplifier. Any movement of the parallel servo output rod produces a feed-back signal opposite in phase to the initiating signal and of a magnitude proportional to the extent of the movement of the parallel servo. This feed-back signal is applied to the summing point between the integrator and the servo amplifier, where it apposes and presently nullifies the integrator output and, consequently, output from the servo amplifier. When this nullifying effect occurs, movement of the parallel servo, and therefore of the elevators, ceases.
- 3.1.8 The system is designed, by the provision of a normal accelerometer and air data transducer components, to produce a given "g" loading in response to a given force applied to the control handgrip, independent of airspeed and altitude. The normal accelerometer provides an output signal of one volt per "g" of loading in the pitch axis. This signal is 180° out of phase with the command signal from the transducer, so that, when the aircraft commences a manoeuvre imposing a "g" loading, the resulting output of the normal accelerometer progressively nullifies the command signal. The command signal is also modified by the air data transducer components to compensate for changes in airspeed and altitude. Thus, since the transducer output signal is proportional to "g" loading, the force that must be applied to the control column handgrip to produce a manoeuvre of a given "g" will be constant, regardless of airspeed and altitude.
- 3.1.9 As described above, force exerted on the control column in a fore or aft motion relative to the neutral position will produce elevator movement in proportion to the applied force, and the elevator movement will cease when the integrator output is balanced by the feed-back signal from the parallel servo. Meanwhile the resultant "g" loading will have produced an accelerometer signal to nullify the signal from the transducer, and the system will remain balanced until a new command signal appears. If the force exerted on the control column handgrip is reduced to zero the signal from the accelerometer is no longer opposed by a signal from the transducer amplifier and therefore acts as a new command signal.



3.1.9 (continued)

Being of equal strength but of opposite phase to the original command signal, its appearance at the integrator input results in the cancelling of the integrator output. The feed-back signal from the parallel servo thereupon finds itself unopposed and returns the parallel servo and therefore the elevators and the control column to a position where the "g" loading is removed from the axis.

- 3.1.10 A slight time lag occurs between the receipt of a signal by the integrator and the subsequent output by the integrator of a signal to the servo amplifier. While this delay has a useful effect in preventing the transmission to the control column via the parallel servo of short-term corrective movements of the elevators (see Sub paras 3.1.12 through 3.1.16) it would also have the undesirable effect of delaying the response of the elevators to command signals but for the action of the differential servos. Command signals which are fed to the integrator are also fed to two differential servos connected into the elevator control linkages. These electro-hydraulic units operate the elevators immediately in response to the command signals. Elevator movement is then taken over by the parallel servo as output becomes available from the integrator. As the command signal circuit to the differential servos does not incorporate an integrator, the differential servos return to their original position as soon as the command signal is nullified by the action of the accelerometer. This allows them to return to their main task of damping uncontrolled movements about the pitch axis as described in sub paras 3.1.13 and 3.1.19.
- 3.1.11 The operation of the command circuits under command signals from the AFCS in the automatic mode of operation is identical with that in the normal mode. In the automatic mode the command signal from the AFCS substitutes for the signal from the transducer.
- 3.1.12 Selecting the landing gear down introduces certain changes in the command circuits. The main effects of such action are to interrupt the command circuit to the differential servos and to prevent the accelerometer output and the airspeed compensation from acting upon the command signal, which is supplied directly to the parallel servo amplifier, by-passing the integrator. These command circuit changes are effected by two fader units and result in elevator movement becoming directly proportional to control column movement without regard to airspeed and altitude. Other effects resulting from selecting the landing gear down are the re-routing of the position trim circuit through a point immediately preceding the integrator instead of through the trim motor (see sub paras 3.1.24 and 3.1.25), and the



SECRET

70/MAINT 13/1

3.1.12 (continued)

shorting out of the integrator in the pitch rate gyro circuit (see sub-para. 3.1.19)

Sensing Circuit

- 3.1.13 A pitch rate gyro is incorporated in the system as a sensing device to correct uncontrolled movement about the pitch axis. On detecting movement the gyro produces a signal which is proportional to the rate of pitch, rather than to aircraft displacement, so that comparatively quick corrective action can be achieved automatically before the displacement becomes significant.
- 3.1.14 The output signal from the gyro is supplied to the circuits of the differential and parallel servos to correct the uncontrolled movement and maintain stable flight.
- 3.1.15 In order to prevent signals from the pitch rate gyro from opposing command signals for pitch changes, an integrator is incorporated in the sensing circuit the function of which is to nullify output signals from the gyro resulting from steady state rates of rotation about the pitch axis.
- 3.1.16 Signals resulting from movement of the aircraft about its pitch axis at a rate of 4 cps or more are referred to as short term signals. Signals produced by movement of less than 4 cps are called long term signals. An operating time lag in the gyro circuit integrator prevents the nulling out of short term signals which are supplied only to the differential servos. It also permits long term signals to appear in the parallel servo circuit, thus initiating corrective movements of the servos. Movement of the parallel servo produces sympathetic movement of the control column via the mechanical linkage of the elevator quadrant so that the balance of the command circuit is maintained. Corrections applied by the differential servos, however, do not produce movement of the control column, the mechanical linkage of the hydraulic jack acting to prevent such an effect.
- 3.1.17 Short term signals resulting from movements exceeding 4 cps about the pitch axis effect the operation of the differential servos only. These signals are not supervised by the gyro circuit integrator because of its operating time lag, and, for the same reason, they do not affect the parallel servo. Thus short term signals are effectively blocked out of the parallel servo circuit where they would produce undesirable control reactions. The differential servos are positioned continuously by the short term signals to correct short term movements automatically and maintain stable flight.



SECRET

70/MAINT 13/1

- 3.1.18 When a corrective movement is initiated and the aircraft commences to return to its original attitude, the signal produced by the gyro will be of the opposite phase. In the case of short term movement, the differential servos will then be moved in the opposite direction, positioning the elevators to limit the correction. In the case of long term movements, the signal cancels the output of the parallel servo integrator, thus permitting the servo feedback signal to operate the amplifier and return the elevators to the neutral position.
- 3.1.19 When the landing gear is selected down and the command circuits are operative as described in sub para 3.1.12, the gyro circuit integrator is shorted out. In this condition steady state pitch rate signals, in addition to long term and short term signals, are supplied to the differential servos. This action aids stability in the pitch axis at low airspeeds.

Trim Circuits

- 3.1.20 Three trim circuits are incorporated in the pitch axis damper channel, via. an acceleration trim circuit, a pressure trim circuit and an artificial feel circuit.

Acceleration Trim Circuit

- 3.1.21 The acceleration trim circuit can be used to trim the aircraft into a "g" manoeuvre. The circuit is controlled by the trim switch on the control column handgrip. Operating the trim switch provides a power supply to a motor-positioned potentiometer incorporated in the trim unit. The voltage picked off this potentiometer is supplied to the summing point of signals from the normal accelerometer and signals from the force transducer or the AFCS. The trim signal operates in the command circuits in the same way as does a command signal.
- 3.1.22 When the trim switch is operated, the movement of the aircraft about the pitch axis produces signals from the rate gyro and the normal accelerometer. The signal from the pitch rate gyro being a steady state signal is nullified by the filter integrator. Note that, due to the inability of the parallel servo integrator to follow, short term signals continue to be provided by the pitch rate gyro to the differential servos only. The output of the normal accelerometer nullifies the trim signal with the same results as when a command signal is nullified. Until the trim switch is again operated, transducer signals will add to or subtract from the standing signal from the trim potentiometer to effect further movement of the elevators.



- 3.1.23 When the pitch axis damper channel is disengaged, the trim switch will govern the feel and trim unit of the artificial feel circuit instead of the position trim circuit. See sub para 3.1.33.
- 3.1.24 When the landing gear is selected down, the power supply from the trim switch is supplied directly to the parallel servo integrator. This prevents the normal accelerometer and the airspeed compensation from acting on the trim signal, these functions being by-passed in the command signal circuits.
- 3.1.25 The output of the integrator is supplied to the summing point of command signals from the force transducer and the parallel servo feed-back circuit. The trim signal will effect movement of the parallel servo until the circuit is balanced by the feed-back signal. Subsequent command signals will then add to or subtract from the standing trim signal to effect further movement of the elevators.

Pressure Trim Circuit

- 3.1.26 The pressure trim circuit is operative automatically when the pitch axis channel of the damper system is disengaged. The function of the circuit is to simulate command signals relative to the position of the elevators. These signals are supplied to the input of the integrator. By this means, when the system is re-engaged, the output of the integrator will correspond with the position of the control column thus ensuring smooth re-engagement.
- 3.1.27 The operation of the circuit is such that during emergency mode operation, the normal feed-back signal produced through movement of the output rod of the parallel servo will continue to be applied to the summing point preceding the servo amplifier. This signal will effect the operation of the amplifier and in turn the transfer valve of the parallel servo. Note that in the emergency mode of operation, action by the transfer valve does not influence the output rod, which is not subjected to hydraulic pressure during emergency mode operation. The operation of the transfer valve results in a pressure differential between the two hydraulic metered supply lines. This action moves a pressure sensing ram which is connected to the core of a trim transformer. The signal from the trim transformer is supplied to the integrator which provides an output signal to nullify the feed-back signal. Due to the inherent time lag of the integrator a portion of the trim transformer signal by-passes the integrator to speed response. See also Disengage Circuits, sub para 3.1.38.



SECRET

70/MAINT 13/1

- 3.1.28 Incorporated in the trim circuit feed-back transformer assembly are two switches. One switch completes the supply circuit to the feel and trim unit of the artificial feed circuit (see sub para 3.1.31.) The other switch functions to prevent the channel engaging if the elevators are moving.

Artificial Feel Circuit

- 3.1.29 The purpose of the artificial feel circuit is to prevent a sudden change in feel at the control column if the pitch axis damper channel dis-engages.
- 3.1.30 The artificial feel circuit consists of an artificial feel and trim unit which comprises an electrically operated actuator and a spring. Operating the actuator increases or decreases the load on the spring dependent upon the direction of rotation of the actuator. One end of the unit is attached to the aircraft structure. The other end is attached to the elevator quadrant, adjacent to the point of attachment of the parallel servo.
- 3.1.31 Exerting a force on the control column handgrip closes a switch which completes a circuit from the actuator to the parallel servo. When the parallel servo operates to execute the command signal the trim actuator receives a power supply. This action increases or decreases the loading of the spring according to the position of the quadrant. If the pitch axis damper suddenly reverts to emergency, the trim unit ensures that the load required on the quadrant by the cables from the control column balances the load that was being imposed on the quadrant by the parallel servo.
- 3.1.32 An additional switch is fitted in parallel with the control column switch to serve as a safety precaution against overstressing the airframe should an automatic mode failure occur. This second switch opens when the normal acceleration exceeds ± 0.5 "g" from straight and level flight condition of the 1 "g". Therefore "g" in excess of this figure applied by the automatic mode is against the feel spring. Consequently, if an automatic mode failure or disengagement occurs the feed spring re-asserts itself and reduces the "g" loading imposed by the elevators to ± 0.5 "g" or less of 1 "g" flight.
- 3.1.33 The feel and trim unit serves also to trim the elevators via movement of the elevator quadrant when the damper channel is disengaged. The actuator in this condition is controlled by the control column trim actuation switch which is transferred automatically, from the acceleration trim motor to the trim actuator upon disengagement of the damper channel.



- 3.1.34 In the event of a seizure in the feel and trim unit, movement of the elevator quadrant would not be possible. To meet this contingency, a release circuit is incorporated in the feel and trim unit linkage to the quadrant. The circuit comprises a control switch fitted in the front cockpit and a solenoid, the plunger of which is attached to a link pin in the feel and trim linkage to the quadrant. Operating the switch energizes the solenoid which extracts the link pin. This action permits the feel and trim unit to pivot freely with movement of the quadrant.

Disengage Circuits

- 3.1.35 The pitch axis disengage circuit operates automatically if the normal acceleration exceeds 5.0 - 5.5 "g". The circuit is controlled by an electronic "g" limiter which, when operated, completes supply circuits to the differential servos centering circuit and the parallel servo disengage circuit. Note that the power supply to the damper system components is uninterrupted in the emergency mode.
- 3.1.36 The pitch axis disengage circuit also operates if the yaw axis monitor acts due to excessive skid, side slip or transverse acceleration.
- 3.1.37 Operation of the disengage circuits reverts the channel to the pre-engage condition and illuminates the R-P AXIS indicator light on the master warning panel. In the pre-engage condition the pressure trim circuit is operative, and the acceleration trim actuation switch is transferred to the trim actuator of the feel trim circuit.
- 3.1.38 When the channel is in the pre-engage condition the output of the force transducer, the normal accelerometer and the pitch rate gyro is routed to the trim unit to ensure smooth re-engagement. A trim unit amplifier, fitted in the circuit immediately preceding the trim unit, discriminates upon the phase of the applied signals to effect the proper direction of rotation of the motor driven potentiometer of the trim unit. The effect of this provision is such that any unbalanced signals appearing in the command circuit initiate the operation of the trim unit and are balanced out by the resulting output signal from the trim unit. This ensures that the channel will be re-engaged into a balanced circuit and as described in sub-paras 3.1.26 and 3.1.27, in agreement with the prevailing position of the elevators. But for this provision, an unbalanced signal, resulting for example from failure of the gyro circuit integrator to nullify a pitch rate signal, would produce unexpected and undesirable movement of the elevators.



SECRET

70/MAINT 13/1

- 3.1.39 Note that if an unbalanced signal is being nulled by the trim unit when re-engagement occurs, the effect is equivalent to introducing an out-of-trim condition on the axis. This is due to the standing trim signal at the summing point of signals from the force transducer and normal accelerometer. In this condition, to regain level flight with the control column in neutral, the trim actuation switch must be operated to cancel the trim signal.





2785-105-1

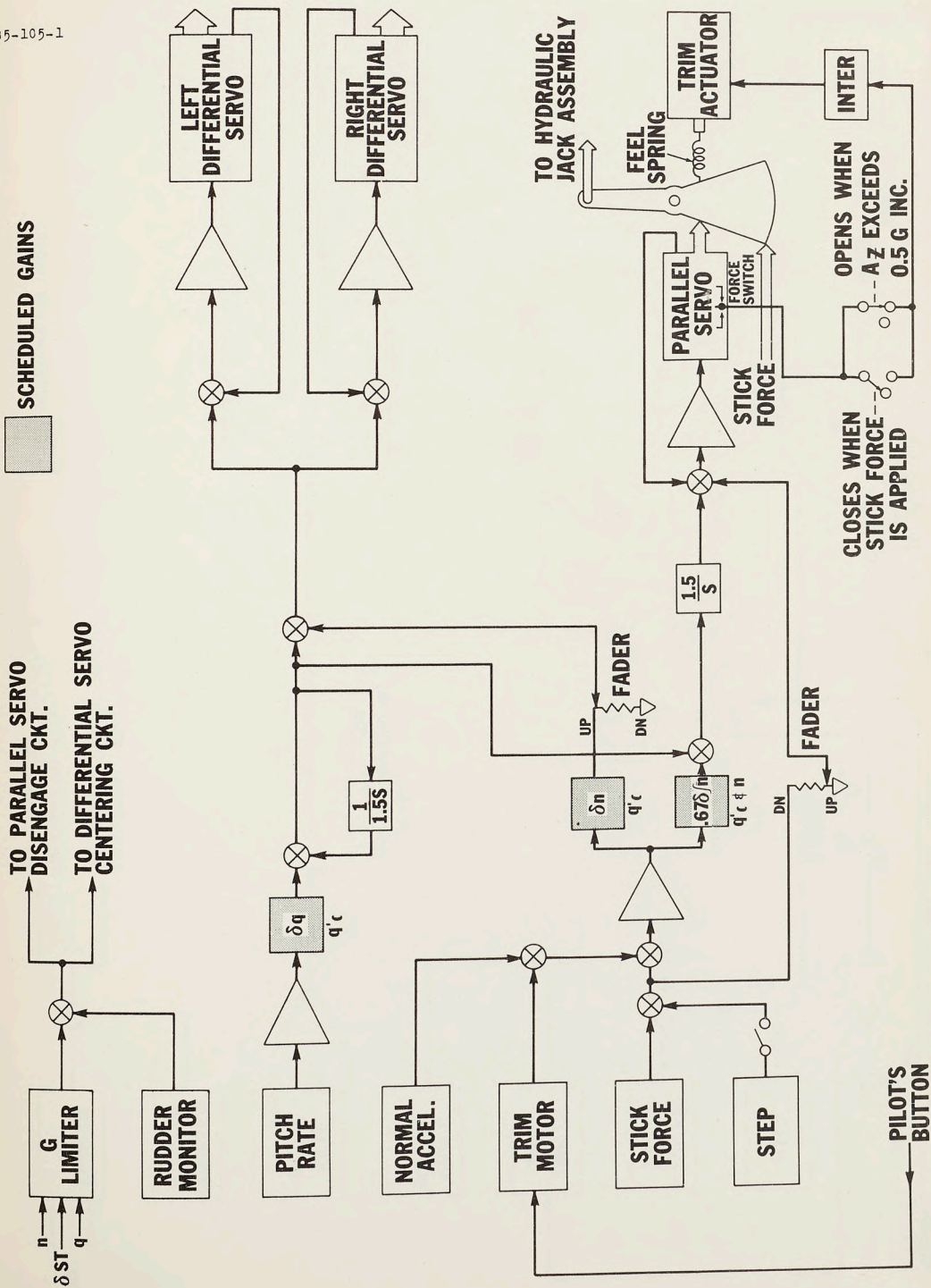

FIG. 4 MH-64 DAMPER, PITCH AXIS, ENGAGE, GEAR UP



2782-105-1

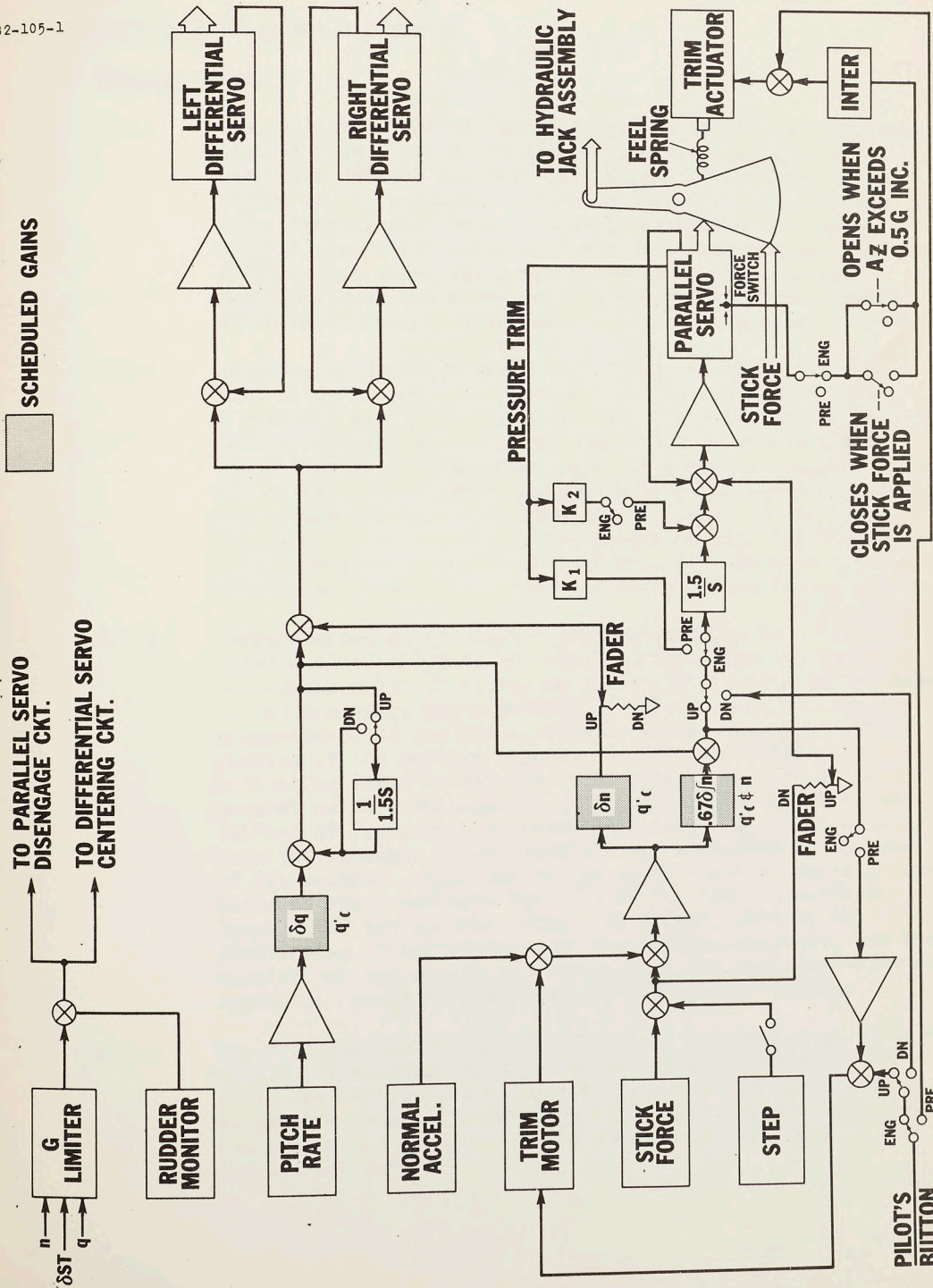

FIG. 5 MH-64 DAMPER, PITCH AXIS, (COMPLETE) SHOWN WITH RELAYS IN ENGAGE AND GEAR UP



3.2 Roll Axis (Figure 6,7,8 and 9)

Command Circuits

- 3.2.1 The roll axis command circuits operate in response to command signals from a force transducer in the normal mode of operation or from the Automatic Flight Control Sub-system (AFCS) in the automatic mode of operation. On receiving such signals, the command circuits actuate an electro-hydraulic parallel servo unit and two electro-hydraulic differential servo units which effect the appropriate positioning of the ailerons. The operation of the command circuits is described in the following paragraphs.
- 3.2.2 In order to reduce elevator trim drag at high altitude, both ailerons are deflected up when the aircraft reaches a pressure altitude of 45,000 feet. This is done by an actuator fitted on the aileron quadrant in such a manner that it drives the quadrant segments apart. The actuator is controlled by a pressure switch adjusted to close and complete the actuator supply circuit at 45,000 feet. To provide an operating differential, the switch is adjusted to re-open at 42,000 feet. The operation of this circuit does not affect the positioning of the ailerons by the damper system.
- 3.2.3 Force exerted on the control column handgrip in a left or right motion, produces an output voltage from the force transducer which is fitted in the control column at the base of the handgrip. The magnitude of this voltage is directly proportional to the force exerted on the handgrip. The phasing of the voltage depends upon the direction of the motivating force relative to the neutral position of the control column, voltages resulting from left motion being 180° out of phase with voltages resulting from right motion. Note that changes in attitude are not commanded by movement of the control column but by the application of force on the handgrip which deflects the core of the force transducer. Movement of the control column, in effect, follows the positioning of the ailerons by the command circuits, but the response of the system is so immediate that attitude changes appear to result from movement of the control column.
- 3.2.4 The roll rate produced is proportional to the output voltage from the transducer, 0.05 volt producing 1°/sec. rate of roll. The maximum output of the transducer is limited by means of mechanical stops to 6 volt, with a force of 20 lb. exerted on the handgrip, which produces a roll rate of 120 degrees per second.



SECRET

70/MAINT 13/1

- 3.2.5 The resulting output from the transducer is supplied via a summing network as a command signal to an integrator unit the output voltage of which increases at a rate directly proportional to the strength of the command signal. The rate of increase of the integrator output is such as to prevent excessive control surface movement. The integrator maintains its output even after the command signal is withdrawn, and until it is provided with a signal of opposite phase to reduce, cancel or reverse the output according to the strength of the new signal.
- 3.2.6 The output of the integrator is supplied through a summing network to a servo amplifier unit. This unit, in addition to its function of amplifying signals, incorporates a discriminator circuit to determine the phasing of the applied signal.
- 3.2.7 From the servo amplifier the signal passes to the transfer valve of an electro-hydraulic parallel servo which controls the aileron movement in magnitude and direction in accordance with the strength and phase of the input signal. The parallel servo effects movement of the ailerons via the aileron quadrant, and so a sympathetic movement of the control column takes place.
- 3.2.8 A self-balancing or feed-back circuit is introduced from the parallel servo to the servo amplifier. Any movement of the parallel servo output rod produces a feed-back signal opposite in phase to the initiating signal and of a magnitude proportional to the extent of the movement of the parallel servo. This feed-back signal is applied to the summing point between the integrator and the servo amplifier, where it opposes and presently nullifies the integrator output and, consequently, output from the servo amplifier. When this nullifying effect occurs, movement of the parallel servo, and therefore of the ailerons, ceases.
- 3.2.9 The system is designed, by the provision of a roll rate gyro and air data transducer components, to produce a given rate of roll in response to a given force and degree of movement applied to the control column handgrip independent of airspeed and altitude. The roll rate gyro provides an output signal of 0.05 volt per unit rate of roll. This signal is 180° out of phase with the command signal. The gyro signal and command signals are also modified by the air data transducer components to compensate for changes in airspeed and altitude. The compensation function is preset to result in a decrease of gain at the extremes of low and high airspeeds and is constant for all other airspeeds. This action aids stability in the roll axis by limiting over-control of the ailerons.



3.2.9 (continued)

Thus, since the transducer output signal is proportional to the applied force and the roll rate gyro output signal is proportional to rate of roll, the force that must be applied to the control column handgrip to produce a manoeuvre of a given roll rate will be constant, except at high and low airspeeds when the force to produce a given rate of roll is increased.

3.2.10

As described above, force exerted on the handgrip in a left or right motion relative to the neutral position will produce aileron movement in proportion to the applied force, and the aileron movement will cease when the integrator output is balanced by the feed-back signal from the parallel servo. Meanwhile the resultant roll rate will have produced a roll rate gyro signal to nullify the signal from the transducer, and the system will remain balanced until a new command signal appears. If the force exerted on the handgrip is reduced to zero, the signal from the roll rate gyro is no longer opposed by a signal from the transducer amplifier and therefore acts as a new command signal. Being of equal strength but of opposite phase to the original command signal, its appearance at the integrator input results in the cancelling of the original signal there and, consequently, in the cessation of integrator output. The feed-back signal from the parallel servo thereupon finds itself unopposed and returns the parallel servo and therefore the ailerons and the control column to a position where the roll rate is zero.

3.2.11

A slight time lag occurs between the receipt of a signal by the integrator and the subsequent output by the integrator of a signal to the servo amplifier. While this delay has a useful effect in preventing the transmission to the control column via the parallel servo of short-term corrective movements of the ailerons (see sub paras 3.2.16 and 3.2.17), it would also have the undesirable effect of delaying the response of the ailerons to command signals but for the action of the differential servos. Command signals which are fed to the integrator are also fed to two differential servos connected into the aileron control linkage. These electro-hydraulic units operate the ailerons immediately in response to the command signals. Aileron movement is then taken over by the parallel servo as output becomes available from the integrator. As the command signal circuit to the differential servos does not incorporate an integrator, the differential servos return to their original position as soon as the command signal is nullified by the action of the roll rate gyro.



3.2.11 (continued)

This allows them to return to their main task of damping uncontrolled movements about the roll axis as described in sub paras. 3.2.14 through 3.2.18.

3.2.12 The operation of the command circuits under command signals from the AFCS in the automatic mode of operation is identical with that in the normal mode. In the automatic mode the command signal from the AFCS substitutes for the signal from the transducer.

3.2.13 Selecting the landing gear down introduces certain changes in the command circuit. One effect of this action is to prevent the roll rate gyro signal and the airspeed compensation from acting upon the command signal. In this condition, the command signal is supplied directly to the parallel servo amplifier. Consequently, movement of the ailerons is directly proportional to control column force regardless of airspeed.

Sensing Circuit

3.2.14 In addition to its function in the command circuit, the roll rate gyro functions as a sensing device to detect uncontrolled movement about the roll axis. Since the gyro output signal is proportional to rate of roll rather than to aircraft displacement, comparatively greater control of the ailerons can be achieved automatically before the displacement becomes significant.

3.2.15 The output signal from the gyro is supplied to the circuits of the parallel and differential servos to correct uncontrolled movement and maintain stable flight.

3.2.16 Signals from the rate gyro resulting from movement exceeding 4 cps about the axis are defined as short term signals and effect the operation only of the differential servos. The short term signals are effectively blocked out of the parallel servos circuit due to the operating time lag of the parallel servo integrator. The differential servos are positioned continuously by the short term signals to suit stability requirements. Corrective movements of the differential servos will not effect movement of the control column.

3.2.17 Long term signals resulting from movement of less than 4 cps about the axis are supplied to the differential servos and the parallel servo. The corrective movement of the parallel servo will effect a movement of control column via the mechanical linkage of the aileron quadrant. This action ensures that the balance of the command circuit is maintained.



- 3.2.18 When a corrective movement is initiated and the aircraft commences to return to its original attitude, the signal produced by the gyro will be of the opposite phase. In the case of short term movement, the differential servos will then be moved in the opposite direction, positioning the ailerons to limit the correction. In the case of long term movements, the signal cancels the output of the integrator, thus permitting the servo feed-back signals to operate through the amplifier and return the ailerons to their original position.

Trim Circuits

- 3.2.19 Two trim circuits are incorporated in the roll axis damper channel, via a roll rate trim circuit and a pressure trim circuit. When the channel is in the pre-engage condition, the emergency trim actuator is operative in place of the roll rate trim.

Roll Rate Trim Circuit

- 3.2.20 When the roll axis damper channel is engaged the roll rate trim circuit is used to trim the aircraft by deflecting the ailerons. The circuit is controlled by the trim switch on the control column handgrip. Operating the trim switch drives a motor-positioned potentiometer incorporated in the trim unit. The voltage picked off this potentiometer is supplied to the summing point of signals from the rate gyro and signals from the force transducer or the AFCS. The trim signal operates in the command circuits in the same way as does a command signal.
- 3.2.21 When the trim switch is operated, the movement of the aircraft about the roll axis produces a signal from the roll rate gyro. This signal nullifies the trim signal with the same results as when a command signal is nullified. Until the trim switch is again operated, transducer signals will add to or subtract from the standing signal from the trim potentiometer to effect further movement of the ailerons.
- 3.2.22 When the roll axis channel is disengaged, the trim switch will govern a trim unit instead of the roll rate trim circuit.
- 3.2.23 The trim unit serves to trim the ailerons via movement of the aileron quadrant. The unit comprises an electrical actuator and a spring. One end of the unit is attached to the aircraft structure. The other end is attached to the aileron quadrant. When the trim switch is operated the trim actuator increases or decreases the loading on the spring so effecting movement of the aileron quadrant.

Pressure Trim Circuit

- 3.2.24 The pressure trim circuit is operative automatically when the roll axis channel of the damper system is disengaged. The function of the circuit is to simulate command signals relative to the position of the ailerons. These signals are supplied to the input of the integrator. By this means, when the system is re-engaged, the output of the integrator will correspond with the position of the control column and will ensure smooth re-engagement.
- 3.2.25 The operation of the circuit is such that during emergency mode operation, the normal feed-back signal produced through movement of the output rod of the parallel servo will continue to be applied to the summing point preceding the servo amplifier. This signal will effect the operation of the amplifier and in turn the transfer valve of the parallel servo. Note that in the emergency mode of operation, action by the transfer valve does not influence the output rod, which is not subjected to hydraulic pressure during emergency mode operation. The operation of the transfer valve results in a pressure differential between the two hydraulic metered supply lines. This action moves a pressure sensing ram which is connected to the core of a trim transformer. The signal from the trim transformer is supplied to the integrator which provides an output signal to null the feed-back signal. Due to the inherent time lag of the integrator a portion of the trim transformer signal by-passes the integrator to speed control response. See also Disengage Circuits sub paras 3.2.28 and 2.3.29.

Disengage Circuits

- 3.2.26 The roll axis channel disengage circuits operate automatically if the roll rate exceeds 159 degrees per second. The circuits are controlled by a roll rate disengage accelerometer which at the predetermined roll rate limit completes supply circuits to the differential servos centering circuit and the parallel servo disengage circuit. Note that the power supply to the damper system components is uninterrupted in the emergency mode.
- 3.2.27 The roll axis disengage circuit will also operate if the yaw axis monitor operates due to excessive skid, side slip, or transverse acceleration.
- 3.2.28 Operation of the disengage circuits reverts the channel to the pre-engage condition and illuminates the R-P AXIS indicator light on the master warning panel. In the pre-engage condition, the pressure trim circuit is operative and the roll rate trim actuation switch is transferred to the aileron trim circuit.



SECRET

70/MAINT 13/1

- 3.2.29 When the channel is in the pre-engage condition the output of the force transducer and the roll rate gyro is routed to the trim unit to ensure smooth re-engagement. A trim circuit amplifier, fitted in the circuit immediately preceding the trim unit, discriminates upon the phasing of the applied signals to effect the proper direction of rotation of the motor-driven potentiometer of the trim unit. The effect of this provision is such that any unbalanced signals appearing in the command circuit initiate the operation of the trim unit and are balanced out by the resulting output signal from the trim unit. This ensures that the channel will be re-engaged into a balanced circuit and, as described in sub paras 3.2.24 and 3.2.25 in agreement with the prevailing position of the ailerons. But for this provision, an unbalanced signal, resulting, for example, from failure of the gyro to nullify a roll rate signal, would produce unexpected and undesirable movement of the ailerons.
- 3.2.30 Note that if an unbalanced signal is being nulled by the trim unit when re-engagement occurs, the effect is equivalent to introducing an out-of-trim condition on the axis. This is due to the trim signal standing at the summing point of signals from the force transducer and normal accelerometer. In this condition, to regain level flight with the control column in neutral, the trim actuation switch must be operated.

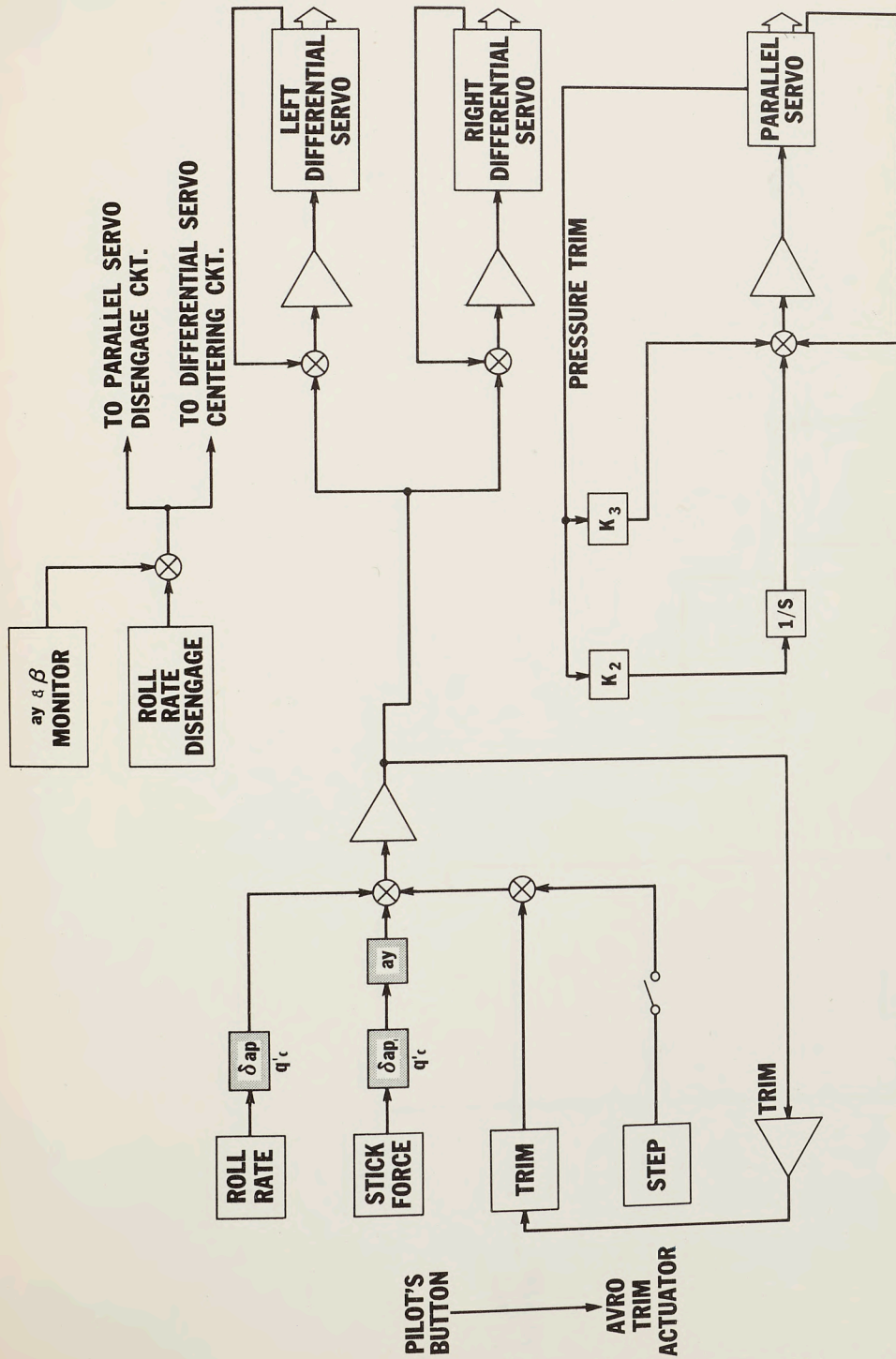

FIG. 6 MH-64 DAMPER, ROLL AXIS, PRE-ENGAGE, GEAR UP OR DOWN



2786-105-1

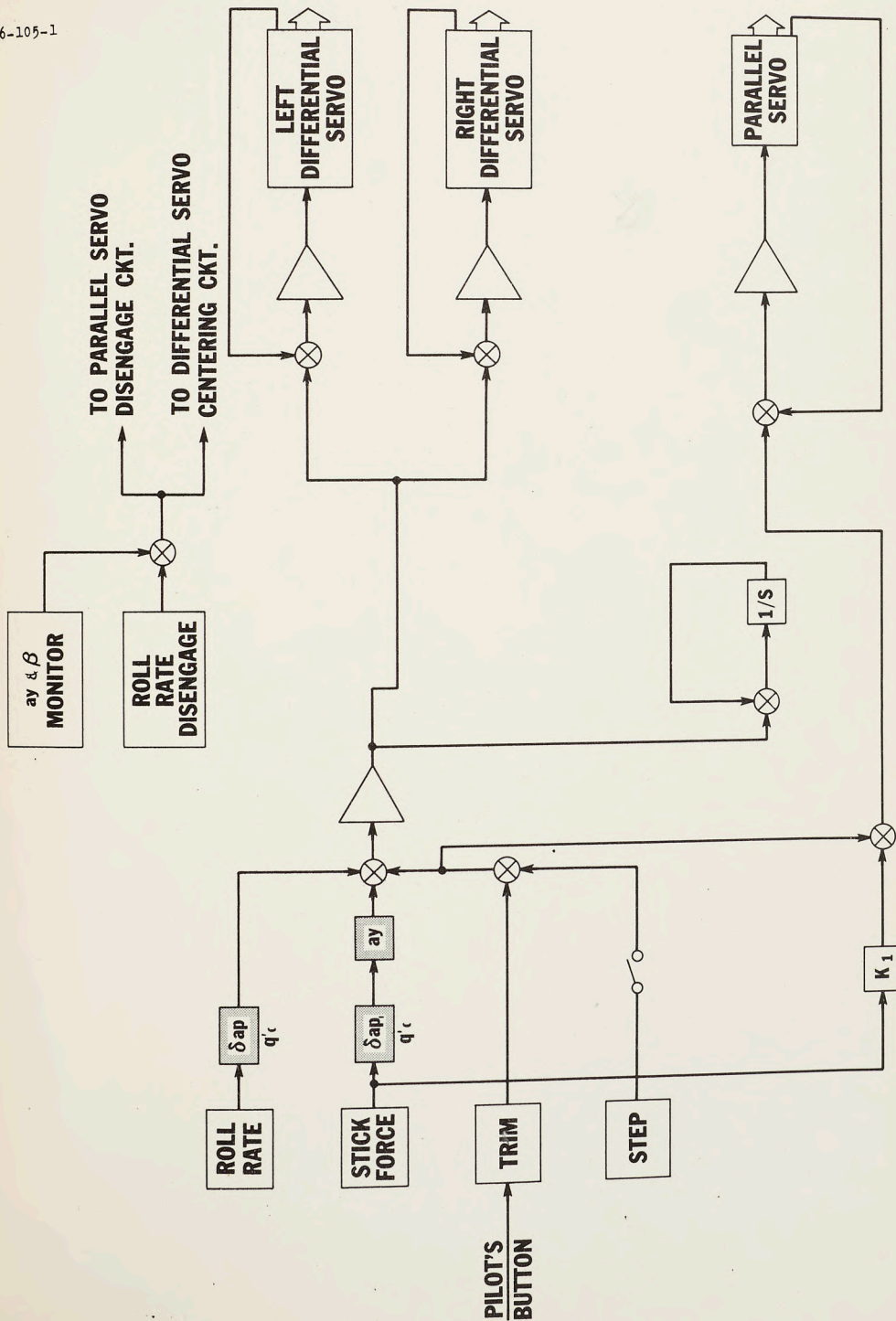

FIG. 7 MH-64 DAMPER, ROLL AXIS, ENGAGE, GEAR DOWN



2786-105-1

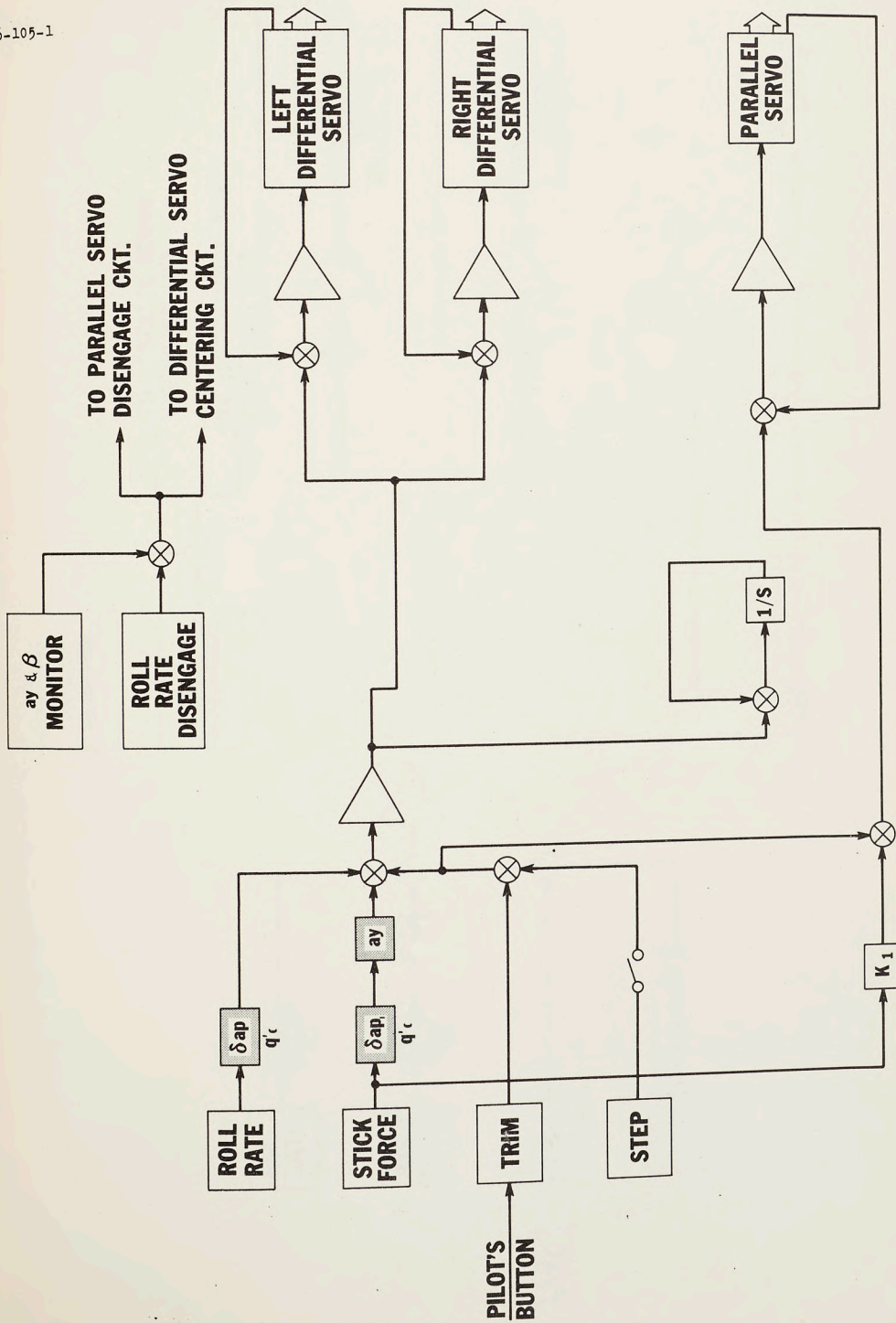

FIG. 7 MH-64 DAMPER, ROLL AXIS, ENGAGE, GEAR DOWN



2778-105-1

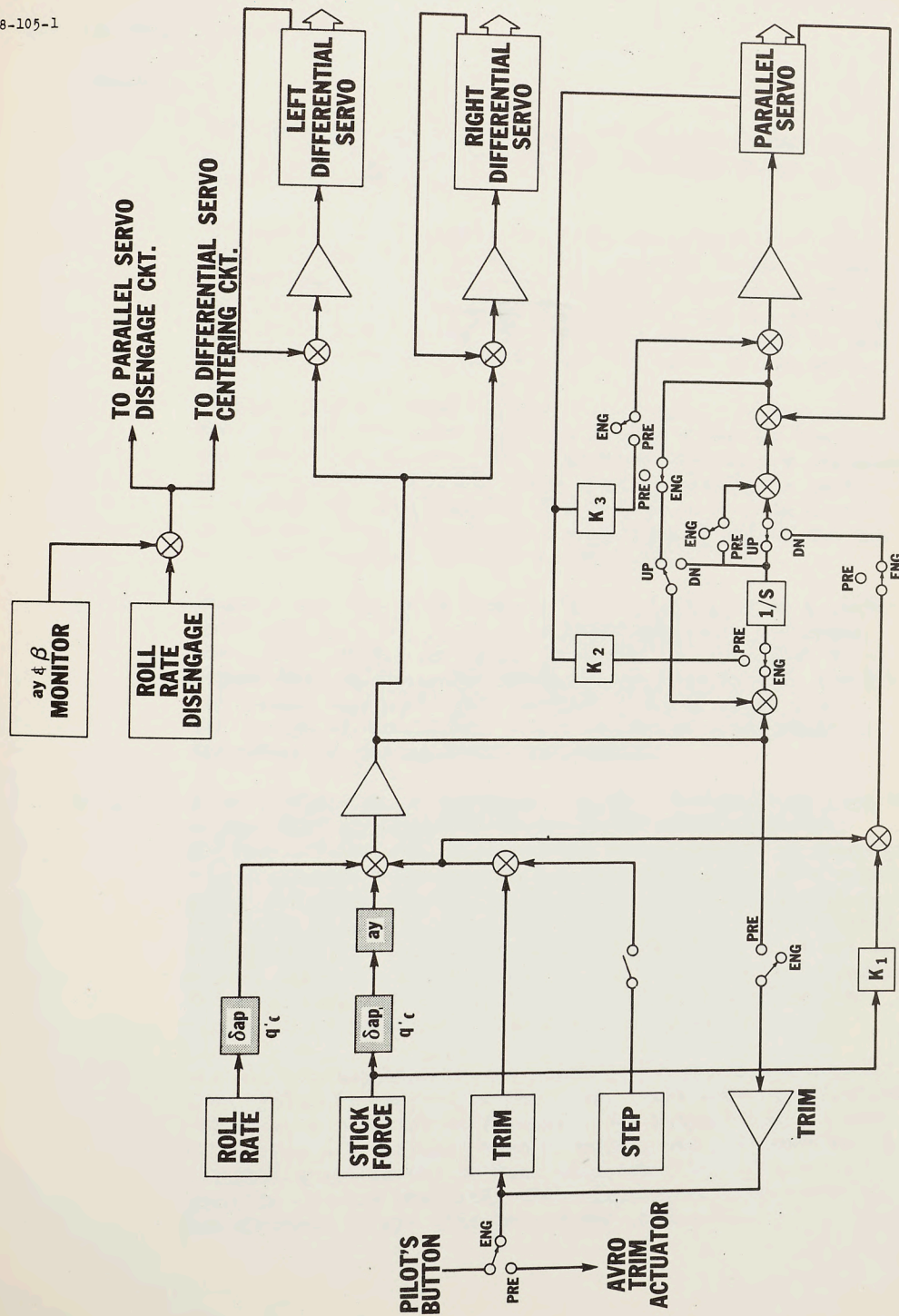

FIG. 9 MH-64 DAMPER, ROLL AXIS, (COMPLETE) SHOWN WITH RELAYS IN ENGAGE AND GEAR UP



3.3 Yaw Axis (Figure 10)

General

- 3.3.1 The yaw axis channel of the damper system corrects yawing motion and provides for co-ordinated rudder movement in manoeuvres as necessary.
- 3.3.2 The channel incorporates two independent systems. One system is operative in the normal mode of damper system operation. The other system is operative only in the event of the normal system disengaging, i.e. in emergency mode operation. Except that a circuit is deleted in the emergency mode, both systems are identical in operation.
- 3.3.3 No independent command signals are supplied to the yaw axis channel in either the normal mode system or the emergency mode system. The motivating signals are provided by sensing devices which operate automatically in particular attitudes of the aircraft. These signals are, in most instances, consolidated at various summing points and the resultant supplied to a servo amplifier.
- 3.3.4 Signals applied to the amplifier are amplified to a usable level and the phasing discriminated against a reference. The output of the amplifier initiates the operation of a rudder dual differential servo valve which in turn operates the rudder hydraulic jack control valve to cause the deflection of the rudder in the direction appropriate to the phase of the amplifier unit input.
- 3.3.5 A self balancing or feed-back circuit is introduced from the rudder dual differential servo to the servo amplifier. Movement of the dual differential servo results in feed-back signal proportional to such movement, appearing at a summing point preceding the amplifier input. When this signal nulls the input signal to the servo amplifier, the servo circuit is balanced and further movement of the rudder does not take place. Upon the input signal to the amplifier being cancelled, the feed-back signal operates the amplifier causing the rudder to be returned to its original position.
- 3.3.6 Signals are supplied by the sensing devices in the normal mode system in respect of yaw rate, transverse acceleration, and aileron position differential by, respectively, a yaw rate gyro, a transverse accelerometer, and a transducer. A signal which is the product of pitch rate and aileron position is also provided. All signals are compensated for airspeed by air data transducer components.



- 3.3.7 The yaw rate and aileron position signals are supervised by an integrator unit whose action is similar to that of the pitch rate axis sensing circuit integrator in that it has no effect on signals of short duration but nullifies steady signals. The integrator also supervises partially the transverse accelerometer signals when the landing gear is selected down.

Yaw Rate

- 3.3.8 The yaw rate signal produced by the yaw rate gyro is of a magnitude and phase appropriate to the rate and direction of yawing motion. Since the gyro signal is proportional to rate of yaw rather than to displacement of the aircraft, comparatively quick corrective action by the rudder can be achieved before the displacement becomes significant. If, in straight and level flight or during turning movements, the yaw rate signal is the result of transient yawing motion, it is applied through the various summing points to the servo amplifier to effect a corrective movement of the rudder. As the aircraft returns to its original attitude, yaw rate signals of the opposite phase are produced which cause the deflection of the rudder in the opposite direction to prevent overshoot. Steady state yaw rate signals will cause an initial deflection of the rudder but, due to the action of the integrator the rudder will be returned to its original position by the feedback signal.

Aileron Position

- 3.3.9 An aileron position signal is produced when the ailerons are moved to commence a turn or to maintain stability. The position of the ailerons is translated by a transducer into an electrical signal, the magnitude and phase of which is dependent on the degree and direction of aileron movement. Note that, as the transducer signal is hi-passed by the filter integrator, the low rate simultaneous up deflection of the ailerons at high altitude will not result in a signal from the transducer. See also sub. para. 3.2.2. The transducer signal is applied through the various summing points to the servo amplifier to effect the deflection of the rudder in the direction appropriate to turn the aircraft and overcome adverse yawing moment resulting from aileron movement.
- 3.3.10 If the aileron position transducer signal is the result of a commanded continuous rolling manoeuvre or of an applied aileron trim the signal will be, in effect, a steady state signal. Therefore, as with a steady state yaw rate signal, the integrator action will cause the rudder to be returned to its original position after the initial deflection or short term co-ordination.



3.3.10 (continued)

Transducer signals resulting from the positioning of the ailerons by the sensing circuit will continually position the rudder to provide co-ordination as required by the corrective movements of the ailerons. As the signals normally originated by the sensing circuit are of relatively short duration, they will not be nulled due to the operating time lag of the integrator.

Transverse Acceleration

3.3.11 Slip or skid in any flight attitude results in a signal originated by the transverse accelerometer being supplied to the servo amplifier to produce a corrective movement of the rudder. As the sideslip motion is eliminated by the applied correction, the output of the transverse accelerometer correspondingly decreases so permitting the servo feed-back signal to decrease the deflection of the rudder.

3.3.12 When the landing gear is selected down, certain circuit changes are effected to by-pass the major portion of the transverse accelerometer signal to the summing point of the yaw rate and aileron position signals. This action subjects the accelerometer signal to supervision by the integrator which nullifies the signal. By this means, the pilot can introduce sideslip without opposition from the yaw axis channel as the yaw rate signals resulting from intentional sideslip will also be attenuated by the integrator. The portion of the accelerometer signal which is not by-passed tends to maintain stability in the axis.

Ailerons Position - Pitch Rate

3.3.13 The simultaneous command of a large rate of roll and degree of pitch would introduce an adverse yawing moment. The signal which is the product of aileron position and pitch rate is utilized in the yaw axis to counteract this condition.

The magnitude of this signal is directly proportional to the aileron position commanded and degree of pitch rate. The signal supplements the short term rudder co-ordination signal, so increasing the deflection of the rudder in relation to the attitudes commanded. As this signal is not supervised by the integrator rudder deflection is applied until the command signals are cancelled.

3.3.14 With the exception of the combined aileron position and pitch rate signal input, the emergency mode system is identical with that of the normal mode system. The changeover from the normal mode to the emergency mode is effected by the push-switch on the control column handgrip or the operation of a rudder monitor which initiates the operation of certain



3.3.14 (continued)

electrical circuits of the rudder dual differential servo and results in the illumination of the roll and/or pitch axis disengage indicator light on the master warning panel. The operation of the emergency yaw damper system is indicated by the illumination of the yaw emergency damper operative indicator, also located on the master warning panel.

- 3.3.15 Note that when the rudder monitor is operated, the pitch axis and roll axis damper circuits are also disengaged. See the Pitch Axis and the Roll Axis Disengage Circuits.

Rudder Monitor

- 3.3.16 The rudder monitor circuit includes a sideslip switch i.e. the beta vane in the nose boom and two transverse accelerometers which are located 13 feet and 40 feet, respectively, forward of the aircraft's centre of gravity. The sideslip switch is set to open and interrupt the normal mode system supply if the sideslip angle exceeds ten degrees. This function is primarily for low airspeeds in which condition a small acceleration may correspond to a large angle of sideslip.

- 3.3.17 The action of the accelerometers is such that one detects direction of sideslip and the other yawing acceleration. If yawing acceleration is sensed which tends to reduce sideslip the changeover circuit will operate at a transverse acceleration value of approximately ± 0.6 "g" at the centre of gravity. Conversely, if the yawing acceleration is such that it tends to increase sideslip the changeover circuit will operate at the relatively lower transverse acceleration values of ± 0.2 "g". This configuration is necessary due to the fact that in co-ordinated manoeuvres relatively large values of transverse and yawing accelerations are required for which the monitor must make provision.

Rudder Feel, Trim and Hinge Moment Limitation

- 3.3.18 A trim circuit is provided to permit the rudder to be trimmed to compensate for steady state yawing motion resulting from asymmetric flight or other causes. The circuit is controlled by a trim switch located in the front cockpit and consists of an actuator fitted as an integral component of the rudder rear quadrant assembly. Operating the trim switch results in the actuator moving the linkage of the rudder hydraulic jack control valve. The movement of the rudder by the trim circuit effects the positioning of the rudder bar.



SECRET

70/MAINT 13/1

3.3.19 In addition to the trim actuator, the rudder rear quadrant assembly incorporates a rudder feel and hinge moment limitation system. This system functions automatically and its action is to decrease the rudder movement for a given force on the rudder bar in proportion to increasing dynamic pressures. This is done to counteract the increased sensitivity of the rudder at high dynamic pressures.



2779-105-1

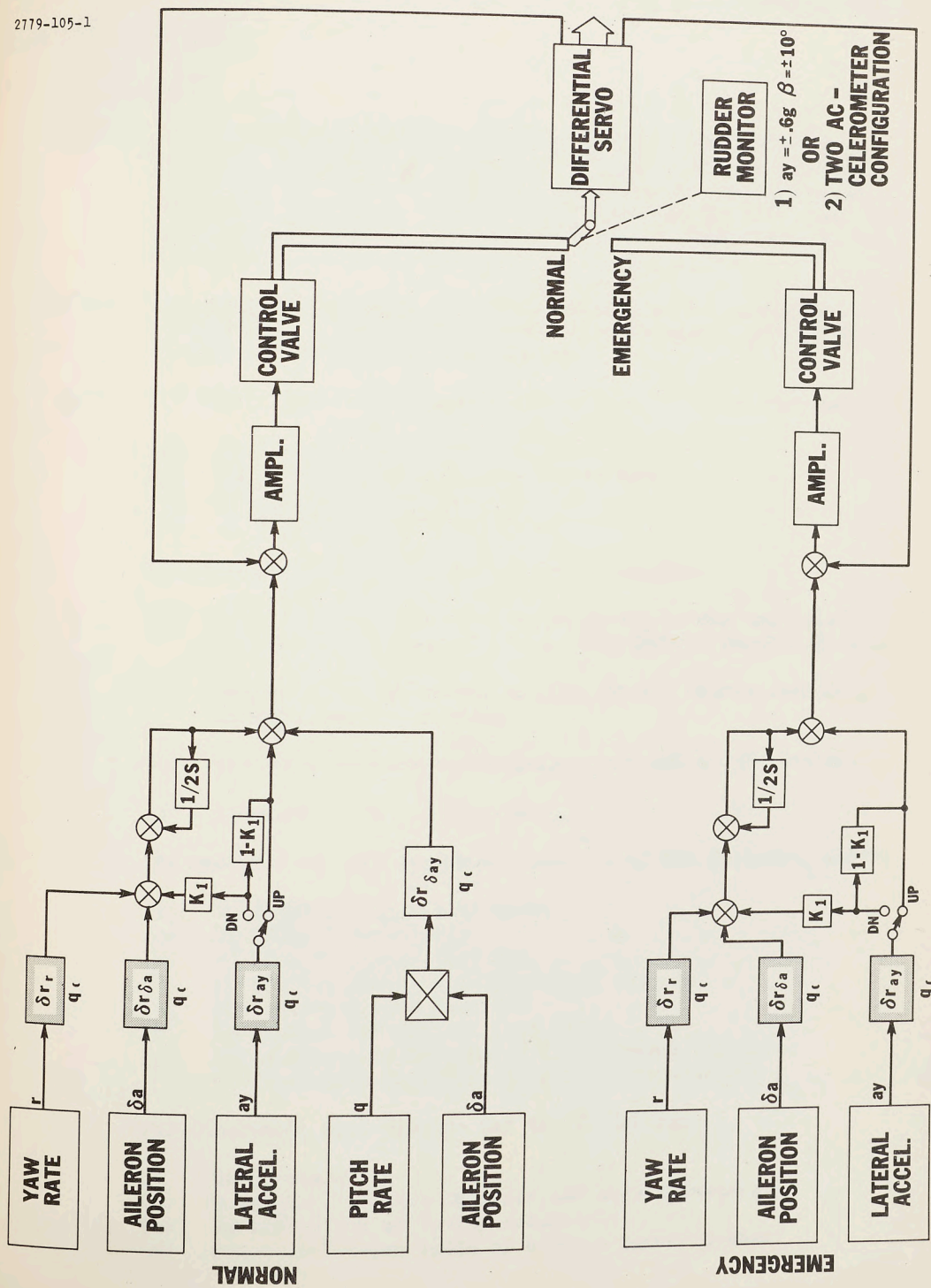

FIG. 10 MH-64 DAMPER, YAW AXIS



4. GROUND TEST EQUIPMENT

4.1 Introduction

4.1.1 The Ground Test Equipment described in this report is the equipment that will be used for the flight test phase of the Damper System program. The equipment has been designed with consideration for its ultimate employment by the RCAF with possible modification and simplification as found required during the flight test phase of the Damper System.

4.1.2 Two types of equipment are used, the first line equipment for primary inspection and the second line equipment that is used to service faulty Damper components.

4.1.3 The first line test equipment consists of the following units:

- (a) UG 6004A-1 Damper Test Set
- (b) UG 6005A-1 Damper Auxiliary Test Set
- (c) MB-1 Pitot-Static Test Set
- (d) UG 6006A-1 "G" Limiter Test Set

This equipment will provide for the following:

- (a) Quantitative "go-no-go" tests on the Damper Amplifier Calibrator, Hydraulic System, and Control Surface Linkage.
- (b) Quantitative tests on the Pitot-Static System including sensors and transducers.
- (c) Qualitative tests on the rate gyros and accelerometers.
- (d) Location of faulty components.

4.1.4 The second line test equipment consists of the following units:

- (a) UG 6003A-1 Damper Test Stand
- (b) UG 6002A-1 Rate Table
- (c) UG 6004A-1 Damper Test Set
- (d) UG 6005A-1 Damper Auxiliary Test Set
- (e) MB-1 Pitot-Static Test Set
- (f) UG 6006A-1 "G" Limiter Test Set
- (g) Servo Hydraulic Test Stand (Requirement for this piece of Test Equipment is being investigated)

This equipment will provide for the following:

- (a) Calibration
- (b) Quantitative tests on gyros and accelerometers.
- (c) Verification of faulty components.
- (d) Pre-installation tests of a whole Damper System



4.2 UG 6004A-1 DAMPER TEST SET

4.2.1 Description

- 4.2.1.1 The UG 6004A-1 Damper Test Set performs "go-no-go" tests on the Damper Amplifier Calibrator, hydraulics, and control surface linkage. When used in conjunction with the MB-1 Pitot-Static Test Set it permits quantitative tests to be performed on the air data sensors and transducers as well.
- 4.2.1.2 The UG 6004A-1 Damper Test Set consists of a source of step and pulsed 400 cycle voltage, Damper Amplifier Calibrator Test Selectors A & B and a bridge circuit for measuring control surface deflection. When the Test Selectors A & B are rotated to the desired position a signal of the proper amplitude and duration is applied to the portion of the Damper bridge selected. A voltage is simultaneously applied to the "qc" scheduler setting the system gain to the desired value. This will cause the control surface to deflect to some pre-determined angle which will be measured by the bridge circuit. One arm of the bridge circuit is a surface position potentiometer whose wiper is mechanically connected to the control surface and whose output voltage is therefore proportional to the surface deflection. The other arm of the bridge is a voltage divider whose output is a voltage corresponding to the desired surface deflection. The voltages from the two arms of the bridge are applied to the SURFACE INDICATOR which indicates the difference between these voltages.
- 4.2.1.3 Selected resistors in series with the SURFACE INDICATOR change the sensitivity such that the coloured area at the centre of the indicator marked "Good" always represents the allowable limits of system performance.
- 4.2.1.4 The UG 6004A-1 Damper Test Set will be of the portable "fly-away" type and capable of being carried by one man. It will have the approximate dimensions:

Length	- 20 inches
Width	- 18 inches
Height	- 8 inches
Weight	- 40 lbs.

4.2.2 Operation

The operation of the UG 6004A-1 Damper Test Set will be explained with reference to Figure 11.



- 4.2.2.1 The sensors are disconnected by removing two connectors from the Damper Amplifier Calibrator and connecting in their place two connectors from the Damper Test Set.
- 4.2.2.2 As the TEST SELECTORS A and B are rotated, pre-selected voltages are applied to each of the Damper Amplifier Calibrator inputs in turn causing control surface deflection. The output of the surface position potentiometer is compared with the voltage from the voltage divider and the difference appears on the SURFACE INDICATOR as a "Good" or "Bad" indication.
- 4.2.2.3 Circuits whose input signals are high-passed are checked in two steps: first as a gain, and secondly as a high-pass signal. In order to test the gain, the output of the high-pass circuit must be zeroed. This is done by allowing the high-pass unit to run until its output is zero when no input is applied to the bridge. The input to the high-pass amplifier is then grounded. The gain of the circuit is then checked as described above and if this is satisfactory, the input signal is maintained and the second step undertaken. The high-pass amplifier is connected to the Damper circuit for one second causing its motor to run applying a voltage to the Damper that cancels a portion of the original step input signal. The amount of cancellation will depend upon the gain of the high-pass amplifier and will appear as a reduction in the surface deflection. A new bucking voltage will be applied to the SURFACE INDICATOR allowing the operation of the high-pass to be read as a "Good" or "Bad" deflection on the SURFACE INDICATOR.
- 4.2.2.4 Integrators are tested by running them for one second with no other signals being applied to the Damper bridge. Satisfactory operation of the integrator will result in a "Good" indication on the SURFACE INDICATOR.
- 4.2.2.5 Schedulers are tested automatically during the series of tests described above. The input to the scheduler must be varied for each input signal in order that the resulting surface deflection remain constant.
- 4.2.2.6 Additional controls on the UG 6004A-1 Damper Test Set are as follows:
- (a) DIRECTION SWITCH - Tests on the Damper are normally performed with the control surface deflecting in one direction only. If the operator desires to check the symmetry of the control surface deflection he may do this by switching the DIRECTION Switch to the "negative" position.



4.2.2.6 (continued)

This reverses the phase of the input signal causing the control surface to deflect in the opposite direction. The bucking voltage applied to the SURFACE INDICATOR is also reversed, so that the control surface deviation indication is still valid.

- (b) ZERO LEFT & RIGHT TRIM CONTROLS - These two controls can be operated when the TEST SELECTORS A and B are selected to the SL (Streamline) position. They permit the technician to zero his SURFACE INDICATOR even if the control surface is not perfectly streamlined. Two controls are used because the two elevators and two ailerons operate independently and it is not likely that their motion will track exactly.
- (c) TEST SELECTOR A - This control applies a signal to each of the inputs to the pitch and roll axis of the Damper bridge as it is rotated through successive positions. Each position of the switch is marked by a symbol representing the particular sensor that this input replaces. These same symbols will appear on all schematic and block diagrams furnished with the test equipment giving the technician a clear reference to that portion of the Damper bridge he is testing.
- (d) TEST SELECTOR B - This control operates in exactly the same manner as TEST SELECTOR A. No inputs will be supplied to yaw axis, however, unless TEST SELECTOR A is in the TO B position for TEST SELECTORS A & B are interlocked to prevent simultaneous inputs to the two axes. When TEST SELECTOR B is selected to the AFCS position it will be possible to use the Damper Test Set with the AFCS Test Set to test the AFCS equipment. TEST SELECTOR A & B positions are as follows:

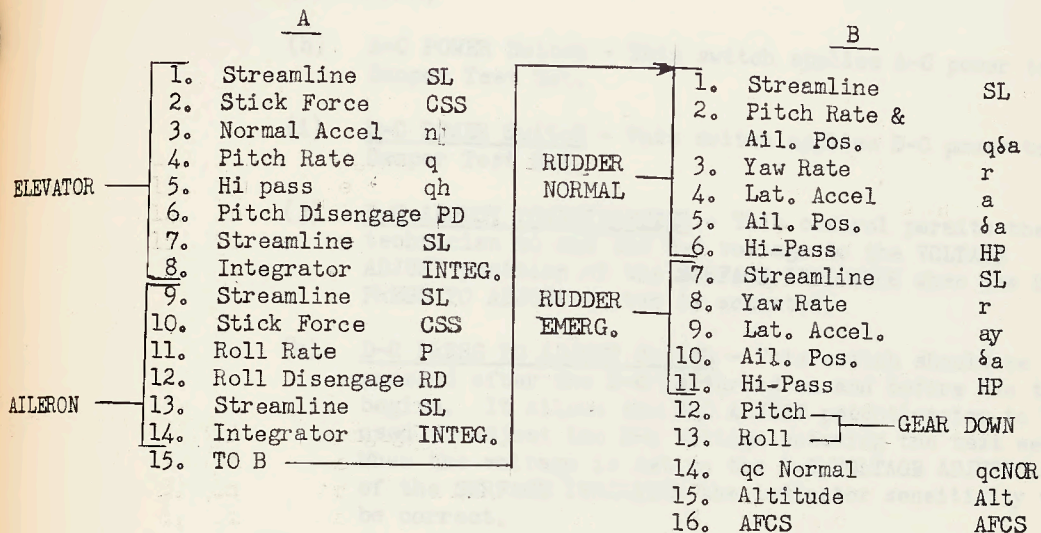

- (e) ELEVATOR/AILERON Switch - This switch is used in conjunction with the TEST SELECTOR A to ensure that the motion of the left and right elevators or ailerons are symmetrical. Normally, these surfaces will be tested with the ELEVATOR/AILERON switch in the "Left" position but it should be selected to the "Right" position for one test as a check on the symmetry of the surface deflection. Symmetrical surface deflection will appear as equal and opposite deflections on the SURFACE INDICATOR.
- (f) EXTERNAL/INTERNAL Switch - This switch is included as part of the UG 6004A-1 Damper Test Set to simplify wiring and to reduce the number of interconnecting wires between this unit and the UG 6005A-1 Auxiliary Test Set. When the EXTERNAL/INTERNAL switch is selected to the INTERNAL position, and the TEST SELECTORS A & B are rotated, the correct values of input voltages to the Damper bridge, the "q c" schedulers, and the bucking voltage to the SURFACE INDICATOR are automatically selected. This reduces the Damper Test procedure to one of rotating a series of switches and observing the deflection of an indicator. When the EXTERNAL/INTERNAL switch is selected to the EXTERNAL position the input voltage and the "q c" inputs are transferred to the Auxiliary Test Set, where the magnitude of these signals may be set to any desired value.
- (g) INTEGRATOR/HIGH-PASS Switch - This switch is to be pressed whenever the TEST SELECTORS A & B are in the HP or INTEG position. It starts the timer motor connecting these units to the circuit for one second.



4.2.2.6 (continued)

- (h) A-C POWER Switch - This switch applies A-C power to the Damper Test Set.
- (i) D-C POWER Switch - This switch applies D-C power to the Damper Test Set.
- (j) D-C ADJUST POTENTIOMETER - This control permits the technician to set the D-C voltage to the VOLTAGE ADJUST position of the SURFACE INDICATOR when the D-C PRESS TO ADJUST switch is actuated.
- (k) D-C PRESS TO ADJUST Switch - This switch should be pressed after the D-C is turned on and before the test begins. It allows the D-C ADJUST potentiometer to be used to adjust the D-C voltage entering the test set. When the voltage is set to the D-C VOLTAGE ADJUST line of the SURFACE INDICATOR the indicator sensitivity will be correct.

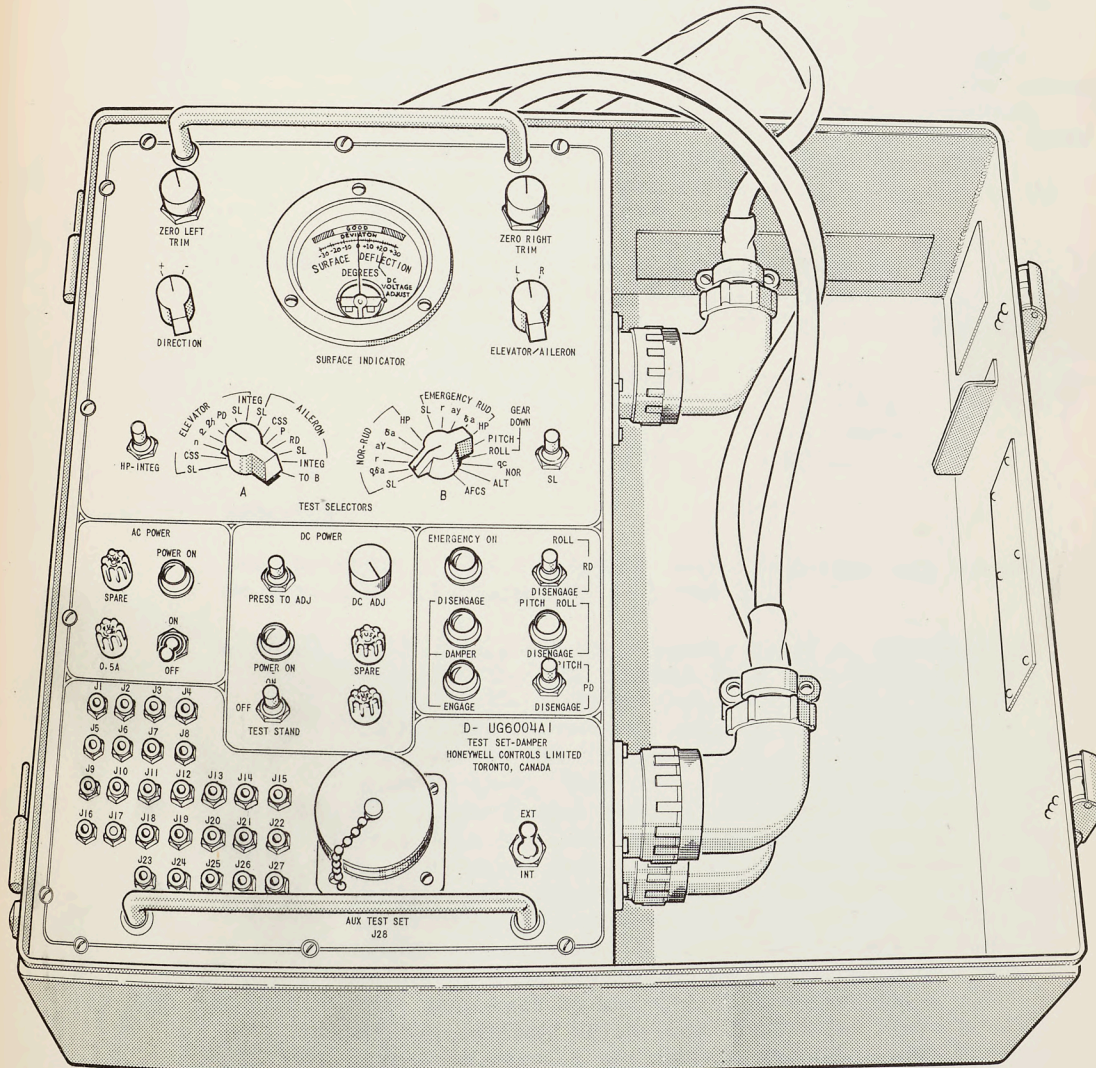

FIG. 11 UG 6004A-1 DAMPER TEST SET



4.3 UG 6005A-1 DAMPER AUXILIARY TEST SET

4.3.1 Description

4.3.1.1 The UG 6005A-1 Damper Auxiliary Test Set must be used with the UG 6004A-1 Damper Test Set to isolate faulty Damper components. The Auxiliary Test Set also permits the measurement of the null voltages from the aircraft gyros and accelerometers, and currents in the servo control valves. It contains circuits allowing manually adjustable voltages other than those pre-selected by the UG 6004A-1 Damper Test Set to be applied to the Damper bridge circuits, and to the Damper scheduler units.

4.3.1.2 The UG 6005A-1 Damper Auxiliary Test Set will be of the portable "flyway" type and capable of being carried by one man. It will have the approximate dimensions:

Length	= 20 inches
Width	- 18 inches
Height	- 8 inches
Weight	- 40 lbs.

4.3.2 Operation

The operation of the UG 6005A-1 Damper Auxiliary Test Set will be explained with reference to Figure 12.

4.3.2.1 Fault isolation in a Damper system is accomplished by using the VTVM (Vacuum Tube Voltmeter) and the SERVO CONTROL CURRENT indicators. When a "no-go" indication is obtained with the UG 6004A-1 Damper Test Set the UG 6005A-1 Damper Auxiliary Test Set must be used. This unit is connected to the UG 6004A-1 Damper Test Set and the portion of the test that produced the faulty output repeated. Faults in the Damper system can be isolated to either the Damper Amplifier Calibrator or the external circuitry by observing the deflection of the SERVO CONTROL CURRENT indicators. No indicator deflection indicates no output from the Damper Amplifier Calibrator and that this unit is faulty. If a deflection on SERVO CONTROL CURRENT indicators is observed that does not reduce to zero as the surface deflects, then the fault in the system is in the servo feed-back transformer, the surface position potentiometer, the inter-connecting cables, or in the hydraulic themselves.



SECRET

70/MAINT 13/1

4.3.2.2 Operation of other controls and indicators on the UG 6005A-1 Damper Auxiliary Test Set are as follows:

- (a) VTVM (Vacuum Tube Voltmeter) - Where it is necessary to measure voltages at various points in the Damper system the VTVM is used. Test points are available on the Damper Amplifier Calibrator chassis and these provide access to most of the Damper gain setting and scheduling potentiometers. Test points that are not accessible on the Damper Amplifier Calibrator are available at the pin jacks on the front of the Auxiliary Test Set.
- (b) VTVM RANGE Switch - This switch is the range selector switch normally associated with a multi-range meter.
- (c) VTVM INPUT Switch - This switch connects the VTVM to each of the sensors in turn and automatically selects the correct range on the VTVM for measuring the null voltages from the various sensors. The additional positions on the VTVM INPUT switch permits the input voltage to the "q c" schedulers to be measured and the input to the VTVM to be switched to a pair of test leads.
- (d) INPUT ADJUST Control - If it is desired to apply some inputs other than the values pre-selected on the UG 6004A-1 Damper Test Set the EXTERNAL/INTERNAL switch located on the Damper Test Set should be selected to the EXTERNAL position. This transfers control of the input signals and the scheduler inputs to the Auxiliary Test Set. The input signal may then be varied by rotating the INPUT ADJUST control until the correct value of input signal is read on the VTVM.
- (e) "q c" ADJUST PSF Selector - Any desired value of "q c" signal may be obtained by selecting the "q c" ADJUST PSF selector to the desired value. The correspondence between the position of the "q c" ADJUST PSF selector and the values of "q c" will be obtained from charts furnished with the equipment.

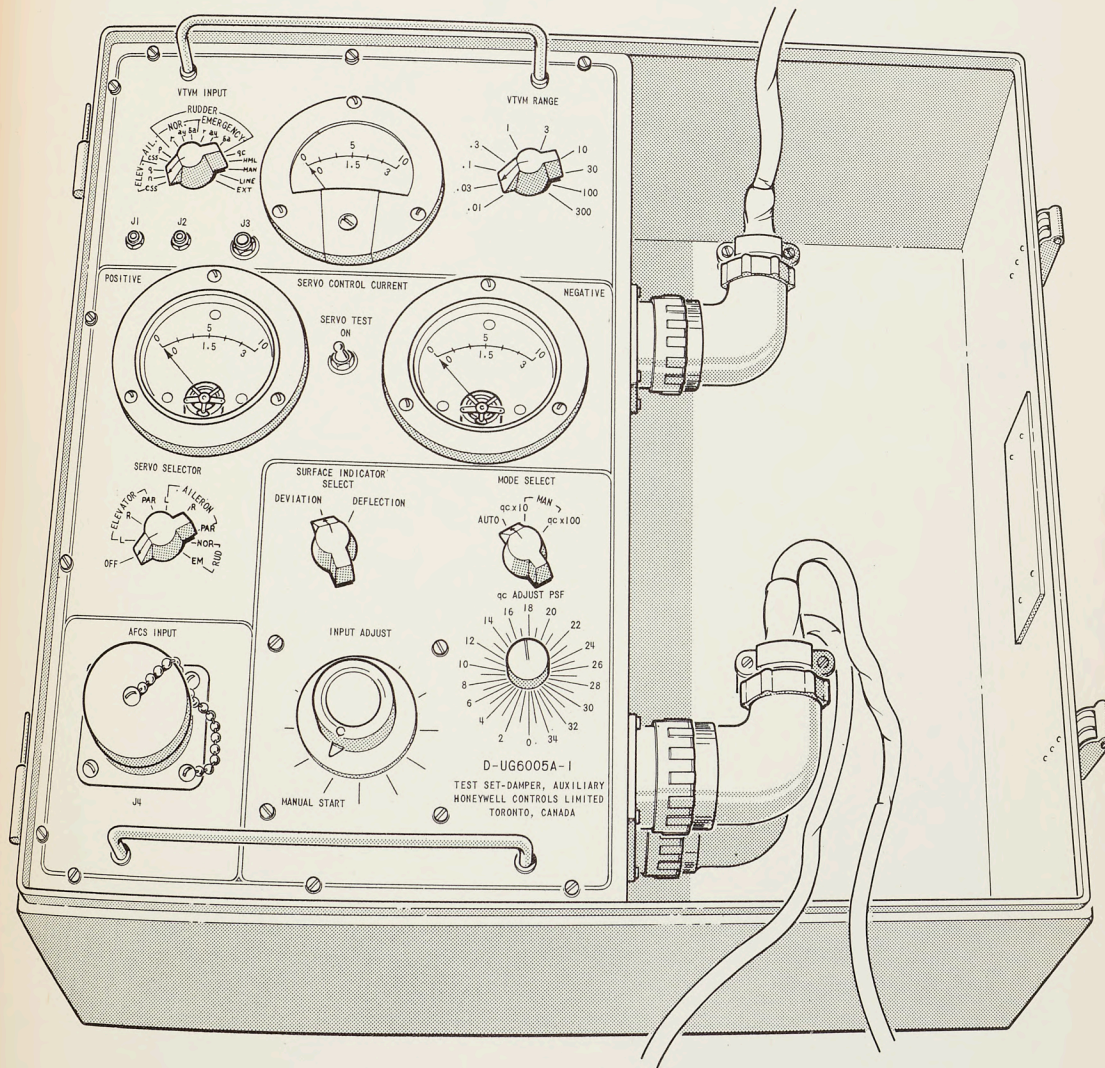

FIG. 12 UG 6005A-1 DAMPER AUXILIARY TEST SET

4.4 MB-1 PITOT - STATIC TEST SET4.4.1 Description (Reference Figure 13)

4.4.1.1 The MB-1 Pitot-Static Test Set will be used to test the normal and emergency pitot-static systems.

4.4.1.2 The Test Set consists of the following equipment:

- (a) 1 hand operated vacuum pump
- (b) 1 hand operated pressure pump
- (c) 5 needle-type control valves
- (d) 1 vacuum gauge
- (e) 1 0-to 80,000 ft. altimeter
- (f) 1 machmeter (to mach. 2.5)
- (g) 1 thermometer
- (h) 1 circular slide rule type computer.

4.4.1.3 The Test Set is a portable unit enclosed in a metal carrying case which has the following dimensions:

Length - 18 inches
Width - 10.5 inches
Height - 6 inches
Weight - 23 lbs.



246-125-1

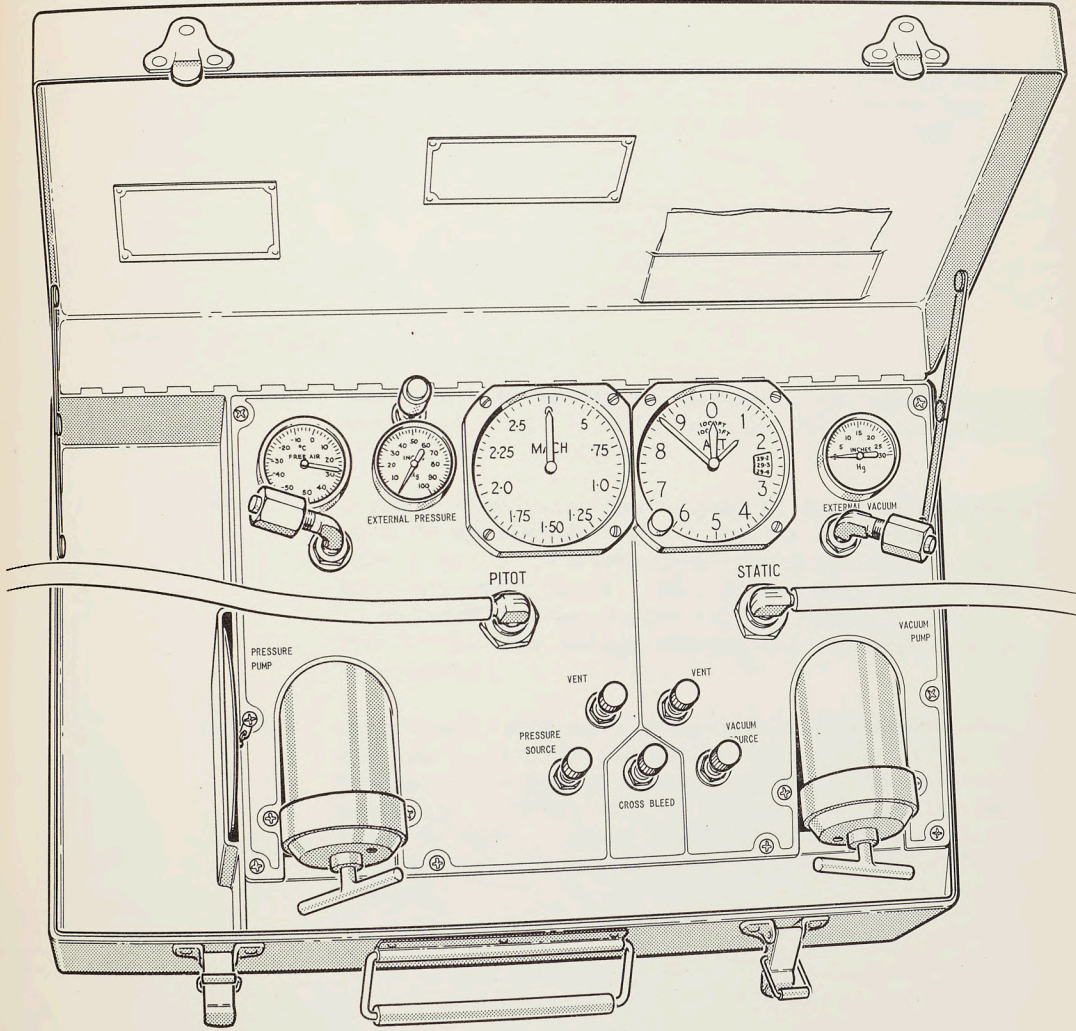

FIG. 13 MB-1 PITOT STATIC TEST SET



4.5 UG 6006A-1 "G" LIMITER TEST SET

4.5.1 Description

4.5.1.1 The UG 6006A-1 "G" Limiter Test Set will permit an independent check to be made of the "G" Limiter calibration.

4.5.1.2 The "G" Limiter Test Set is a self-contained unit and will be stored in the UG 6004A-1 Damper Test Set carrying case, it will have the following dimensions:

Length	- 5 inches
Width	- 4 inches
Height	- 6 inches
Weight	- 3 lbs.

4.5.2 Operation

4.5.2.1 It will be necessary to disconnect the accelerometers and stick force signals from the "G" Limiter Calibrator to test the "G" Limiter.

4.5.2.2 Signals simulating the outputs of the accelerometers will be applied to the "G" Limiter calibrator. A step input of pre-determined amplitude will be fed into the stick input. This signal when high-passed in the "G" Limiter Calibrator will apply a pulse to the "G" Limiter bridge causing the disconnect relay to operate .

4.5.2.3 Additional tests will apply simulated accelerometer signals to the "G" Limiter bridge to cause the disconnect relays to operate. Both the normal and emergency limiters will be checked for positive and negative "G"'s. Panel lights on the "G" Limiter Test Set will indicate proper operation of the "G" Limiter.



4.6 UG 6003A-1 DAMPER TEST STAND

4.6.1 Description (Reference Figure 14)

- 4.6.1.1 The UG 6003A-1 Damper Test Stand is a combination bench and transit case. Damper components are mounted on brackets which form part of the stand and are electrically interconnected by means of cables provided with the Test Stand.
- 4.6.1.2 Space is provided to mount the UG 6004A-1 Damper Test Set, and the UG 6005A-1 Damper Auxiliary Test Set on a shelf above the Damper components. Space is also provided to mount the MB-1 Pitot Static Test Set.
- 4.6.1.3 The UG 6003A-1 Damper Test Stand is of the "fly-away" type. The overall stand dimensions and weights without Damper components are approximately as follows:

Closed for transportation

Length	- 48 inches
Width	- 34 inches
Height	- 36 inches
Weight	- 200 lbs.

Open

Length	- 77 inches
Width	- 34 inches
Height	- 60 inches
Weight	- 200 lbs.

- 4.6.1.4 The power required to operate the Test Stand will be 27.5 volts d-c with an input current of 10 amps and 115 volts, three phase, 400 cps at 5 amps.

4.6.2 Operation

- 4.6.2.1 The Test Stand will be used for calibrating components, confirming faulty components and pre-installation tests of a complete Damper System. It will allow gains to be adjusted, faulty components to be isolated, and the cause of the fault determined.
- 4.6.2.2 Manually adjustable feed back potentiometers are provided to replace the inductive pick-off connected to the servo unit. This will prevent saturation of the servo amplifier. In practice, a step input will be applied to the Damper System and the feedback potentiometer adjusted for minimum deflection of the SERVO CONTROL CURRENT indicators which are located on the UG 6005A-1 Auxiliary Test Set. A surface position potentiometer ganged to the feed back



SECRET

70/MAINT 13/1

4.6.2.2 (continued)

potentiometer will provide the necessary voltage for operating the SURFACE INDICATOR on the UG 6004A-1 Damper Test Set.

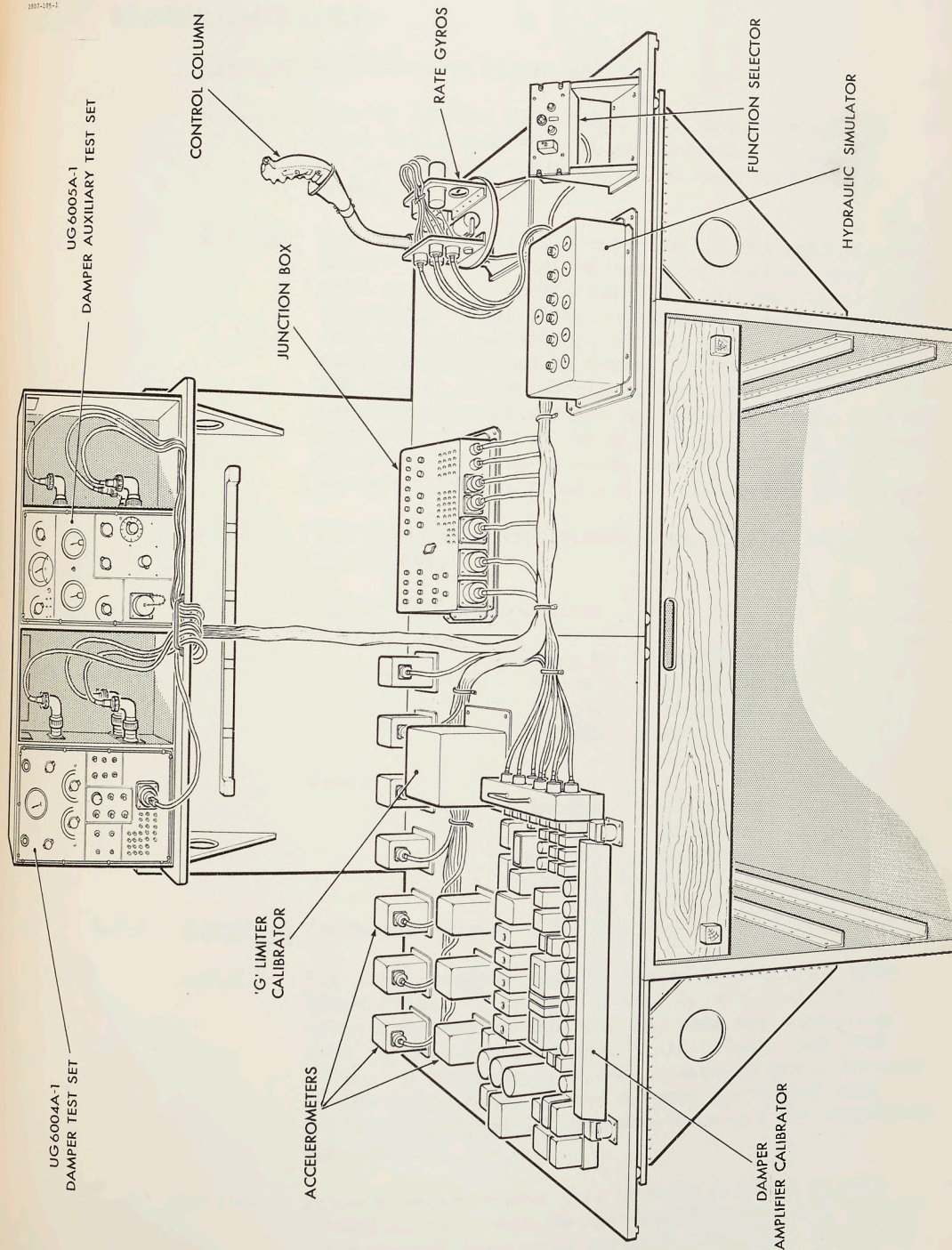

FIG. 14 UG 6003A-1 DAMPER TEST STAND

4.7 UG 6002A-1 RATE TABLE4.7.1 Description (Reference Figure 15)

- 4.7.1.1 The UG 6002A-1 Rate Table is a Genisco Model 181 Rate Table mounted with an operating console in an air-transportable case that also serves as a stand.
- 4.7.1.2 The operating console contains all the switches and meters necessary to perform quantitative tests on the rate gyros and accelerometers. The gyro tests include linearity, sensitivity and maximum turning rate as well as the measurement of spin motor currents. The accelerometers can be tested for sensitivity, linearity and range. Those accelerometers that perform switching operations can be tested to ensure that their operation is within the allowable limits of performance. Provision is made to check the continuity of the heaters in those gyros and accelerometers so equipped.
- 4.7.1.3 The Rate Table approximate dimensions and weight are as follows:

Closed for transportation:

Length - 48 inches
Width - 48 inches
Height - 36 inches
Weight - 400 lbs.

Open:

Length - 48 inches
Width - 48 inches
Height - 56 inches
Weight - 400 lbs.

4.7.2 Operation (Reference Figure 15)

- 4.7.2.1 The accelerometers can be tested by comparing their linearities. This can be done by mounting two accelerometers on the rotating beam and connecting them in such a manner that their outputs buck each other. A meter is provided to measure the difference in the outputs and if the outputs are within some predetermined levels the accelerometers are considered serviceable.
- 4.7.2.2 Those accelerometers that operate a switch at some preset acceleration can be tested by rotating them at a speed such that accelerations just above and below these limits are obtained. The operation, or non operation of the acceleration limit switch will be an indication of the serviceability of the accelerometer.



2824-105-1

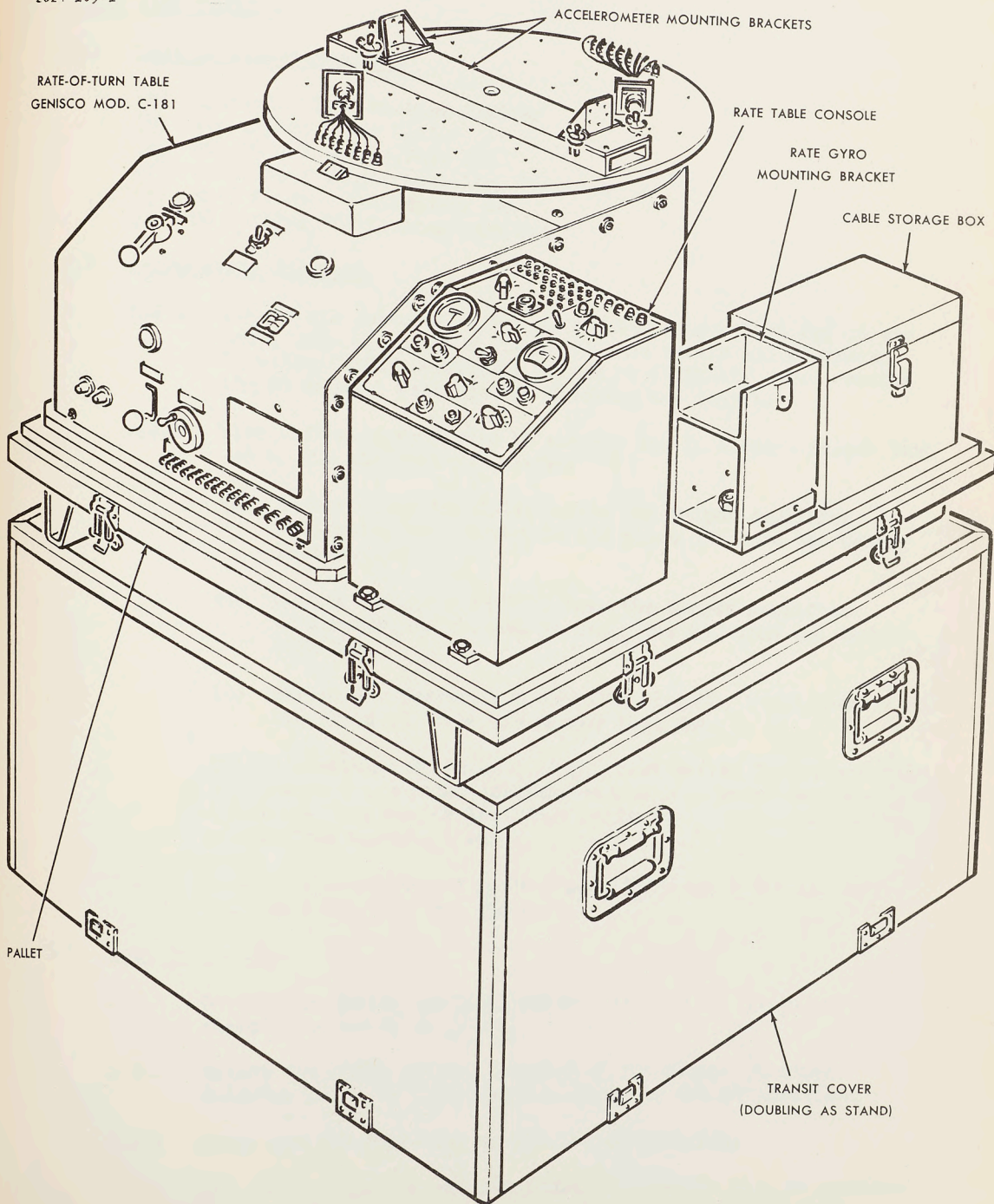

FIG. 15 D-UG6002A-1 RATE TABLE



5. FIRST LINE TESTING

5.1 Test Equipment Required

- (a) Hydraulic Test Machine Trailer
- (b) A-C Ground Power Unit
- (c) UG 6004A-1 Damper Test Set
- (d) UG 6005A-1 Damper Auxiliary Test Set
- (e) MB-1 Pitot - Static Test Set
- (d) UG 6006A-1 "G" Limiter Test Set

5.2 Preparation for Test

5.2.1 Rotate all switches on the UG 6004A-1 Damper Test Set to the left, turn all power switches OFF and centre all controls. Turn the EXTERNAL-INTERNAL switch to INTERNAL. This readies the UG 6004A-1 Test Set for checking the Damper.

5.2.2 With reference to Figure 15 connect the UG 6004A-1 Damper Test Set to the aircraft as follows:

- (a) Remove connector R1087/5 from the Damper Amplifier Calibrator and connect in its place P29 from the Damper Test Set.
- (b) Remove connector R1087/8 from the Damper Amplifier Calibrator and connect in its place P30 from the Damper Test Set.
- (c) Remove the Damper Test Shorting Plug No. 2 and connect in its place P31 from the Damper Test Set.

This connects the UG 6004A-1 Damper Test Set to the Damper and surface position potentiometers permitting "go-no-go" checks to be made on the Damper Amplifier Calibrator, hydraulic system and control surface linkage.

5.2.3 Connect the A-C Ground Power Supply Unit and Hydraulic Test Machine Trailer to the aircraft.

5.3 Test Procedure

5.3.1 Select the MASTER ELECTRIC switch, located in the pilot's cockpit to the ON position.

5.3.2 Select the POWER switch, located on the Damper Function Selector Panel in the pilot's cockpit to the ON position.

5.3.3 Carry out the following on the Damper Test Set.

- (a) Select the A-C and D-C POWER switches to the ON position and check that the POWER ON lights are illuminated.

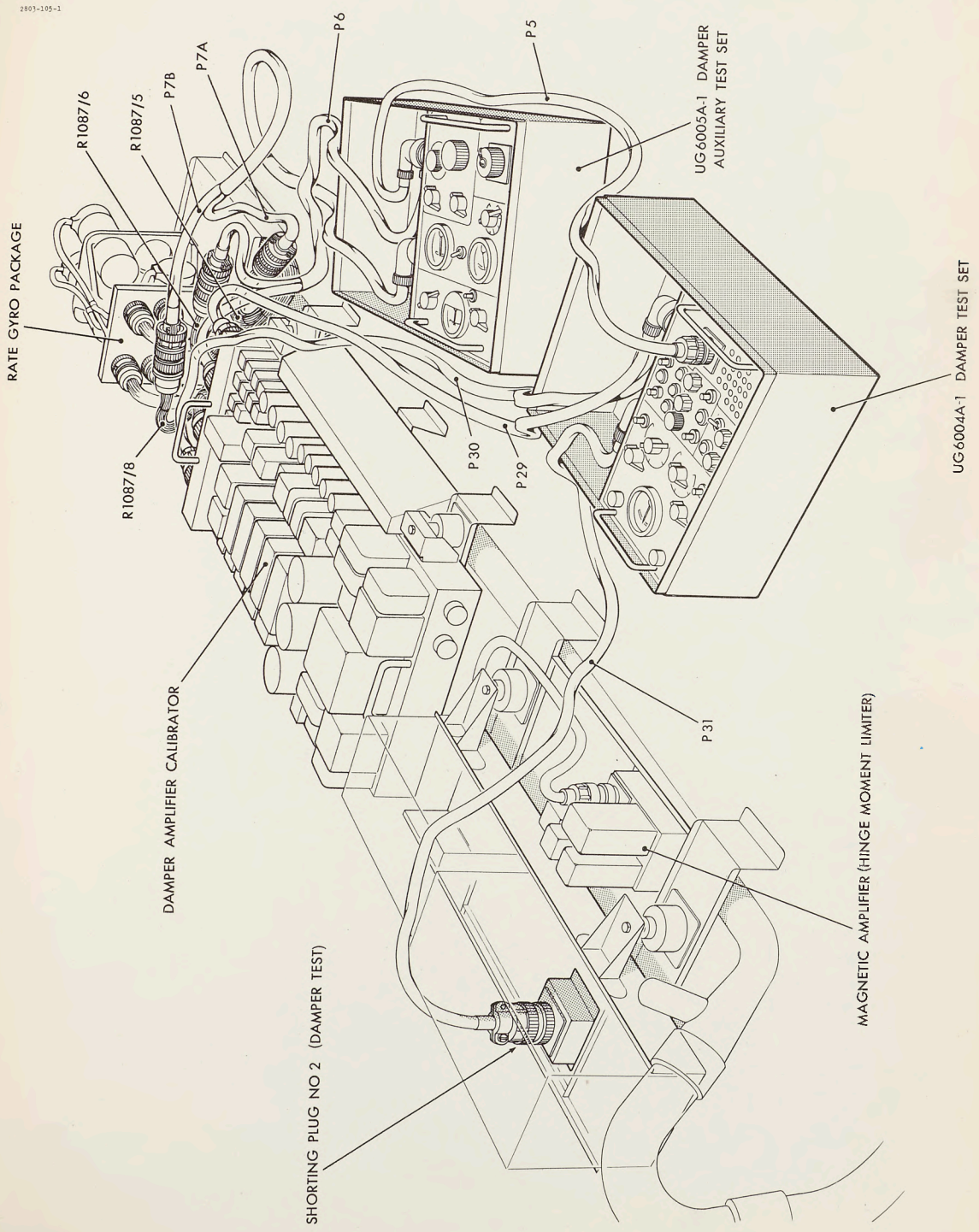

FIG. 16 CONNECTING TEST EQUIPMENT TO AIRCRAFT



- (b) Press the D-C PRESS TO ADJUST push-switch and adjust the D-C ADJUST control until the pointer of the SURFACE INDICATOR is at the D-C VOLTAGE ADJUST position.
- (c) Engage the Damper by pressing the DAMPER ENGAGE push-switch located on the Damper Test Set.
- (d) Ensure that TEST SELECTOR A is selected to the first "SL" position. With the Damper Test Set as above a zero signal is applied to the pitch axis bridge which should result in zero surface deflection producing a zero reading on the SURFACE INDICATOR. Should the control surface not be streamlined a non zero reading will be read on the SURFACE INDICATOR. This indicates residual signal in the damper bridge, faulty mechanical linkage or a faulty servo control valve operation. If the surface is only slightly off the streamline position it is quite likely that the trouble lies in faulty mechanical linkage and the procedure in sub para 5.3.4 should be followed.

5.3.4 If the SURFACE INDICATOR does not read zero adjust the ZERO LEFT TRIM control unit it does. The control index should not need to be rotated more than ___° in order to zero the SURFACE INDICATOR.

5.3.5 Select the ELEVATOR/AILERON switch to the "R" position and adjust the ZERO RIGHT TRIM control until the SURFACE INDICATOR reads zero. Select the ELEVATOR/AILERON switch to the "L" position. This test ensures that both the left and right elevators are in the streamline position or that the streamlining has been corrected for electrically in the test set.

NOTE: - All tests but one on the pitch axis damper will be performed by energizing the differential servos only. In addition, the tests are performed on the "gear up" configuration so that the fader potentiometer to the differential servo bridge is at its full gain end, and the parallel servo fader potentiometer is at its zero gain end. Furthermore, the output of the integrator in the parallel servo circuit is fed-back to the input of the integrator forming a high pass circuit to prevent the integrator from drifting. These precautions prevent the tests on the differential servos from being confused by such factors as improper operation of the integrator and altitude scheduler or by integrator drift. The deflection of the control surface for all tests on the differential servos will be approximately five degrees. The operation of the integrator and parallel servo will be tested at the "PD" position of the TEST SELECTOR A and the fader circuits will be tested at the PITCH GEAR DOWN position of the TEST SELECTOR B.



- 5.3.6 Select the TEST SELECTOR A to the "CSS" position. A signal voltage simulating that from the stick force transducer is injected into the pitch axis bridge causing the control surface to deflect. A second voltage is simultaneously applied to the D-DG 33A unit causing it to run to some predetermined position, automatically adjusting the gain of the Damper circuit. The combination of input voltage, manual gain, and automatic gain determines the control surface deflection. The signal voltage and scheduling voltage are set to produce a deflection of approximately 5°.
- 5.3.7 A potentiometer attached to the control surface produces an output voltage proportional to the surface deflection and this voltage is compared with a fixed voltage in the Test Set and displayed on the SURFACE INDICATOR. If the difference between these two voltages is within tolerance the needle of the SURFACE INDICATOR will deflect within the GOOD portion of the scale.
- 5.3.8 Select the ELEVATOR/AILERON switch to the "R" position, the SURFACE INDICATOR should read GOOD. Return the ELEVATOR/AILERON switch to the "L" position. This checks that the motion of the left elevator is equal to that of the right elevator.
- 5.3.9 Select the DIRECTION switch from the "+" position to the "-" position. This causes the elevators to deflect in the opposite (down) direction. A GOOD reading should be obtained on the SURFACE INDICATOR indicating that the motion of the control surface is symmetrical. Return the DIRECTION switch to the "+" position.
- 5.3.10 Select the TEST SELECTOR A to the "n" position. The SURFACE INDICATOR should read GOOD. It should be noted that it is no longer necessary to rotate the ELEVATOR/AILERON switch or the DIRECTION switch to check that the symmetry of the elevator deflection is correct since this symmetry has already been established on the "CSS" position of the TEST SELECTOR A.
- 5.3.11 Select the TEST SELECTOR A to the "q" position. A GOOD indication on the SURFACE INDICATOR should be obtained.
- 5.3.12 Select the TEST SELECTOR A to the "q h" position and press the HP-INTEGRATOR push-switch. When the TEST SELECTOR A is first selected to the "q h" position, the SURFACE INDICATOR will deflect off the scale but will gradually come back to the GOOD portion of the scale within _____ seconds after the HP-INTEGRATOR push-switch is pressed. A GOOD reading will indicate that the high pass portion of the pitch rate circuit is operating properly. During all the previous tests (except 5.3.11 above) the high pass unit has been connected to the Damper bridge in such a manner that no signal will reach the parallel servo amplifier.



5.3.12 (continued)

When the TEST SELECTOR A is selected to the "q h" position a signal simulating pitch rate is applied to the bridge causing the elevators to deflect, (the high pass unit is grounded to prevent drift) and the SURFACE INDICATOR to deflect off the scale. When the HP-INTEGRATOR switch is pressed the ground is removed and the high pass unit is connected to the bridge for _____ seconds causing the high pass unit to operate and "washing out" a portion of the input signal, there-by reducing the amount of elevator deflection. If the operation of the high pass circuit is correct, the needle of the SURFACE INDICATOR will return to the GOOD portion of the scale. This test actually checks the time constant of the high pass unit.

- 5.3.13 Select the TEST SELECTOR A to the "PD" position. The SURFACE INDICATOR should read approximately 5°. Hold down the PITCH DISENGAGE push-switch. The SURFACE INDICATOR reading should now decrease to zero. If the SURFACE INDICATOR does not return to zero but remains fixed, a faulty differential servo is indicated. If the surface deflection increases, the parallel servo is not disengaged. When a faulty differential servo is indicated it will be necessary to repeat step 5.3.13 but with the ELEVATOR/AILERON switch in the "R" position to determine if the fault is common to both differential servos.

NOTE:- Reengage the Damper by pressing the ENGAGE push-switch.
Return the ELEVATOR/AILERON switch to the "L" position.

- 5.3.14 Select the TEST SELECTOR A to the "SL" position and check that the SURFACE INDICATOR is at zero deviation for both left and right elevators. This test ensures the proper streamlining of the control surface before checking the pitch axis integrator.
- 5.3.15 Select the TEST SELECTOR A to the "INTEG" position and press the HP-INTEGRATOR push-switch. The SURFACE INDICATOR needle will first go off the scale but should return within the GOOD portion within _____ second if the integrator is operating properly. This test checks both the operation of the integrator and of the parallel servo, for in this case no signal is applied to the differential servo; the control surface motion being carried by the parallel servo. The integrator is tested by applying a signal of known amplitude and duration when the HP-INTEGRATOR push switch is pressed, causing the unit to run and produce a pre-determined known surface deflection.
- 5.3.16 Select the TEST SELECTOR A to the AILERON "SL" position and check that the left and right ailerons are streamlined by means of the ELEVATOR/AILERON switch as described in step 5.3.7 for the elevator. Return the ELEVATOR/AILERON switch to the "L" position. Select the TEST SELECTOR A to the "CSS" position and ensure the SURFACE INDICATOR deflects within the GOOD portion of the scale.



- 5.3.17 Select the DIRECTION switch to the " - " position and the ELEVATOR/AILERON switch to the "R" position. A GOOD reading should be obtained on the SURFACE INDICATOR indicating that control surface motion is symmetrical. Test 5.3.16 and 5.3.17 are necessary to ensure proper operation of both the left and right aileron servo systems as each is separately powered.
- 5.3.18 Select the TEST SELECTOR A to the "P" position and ensure that the deflection is GOOD. It is no longer necessary to rotate the DIRECTION switch and the ELEVATOR/AILERON switch to ensure that aileron position is symmetrical since this has already been checked in 5.3.16 and 5.3.17 and only those portions of the bridge that are common to both surfaces are now being tested.
- 5.3.19 Select the TEST SELECTOR A to the "RD" position. The SURFACE INDICATOR should read approximately 5° . Press the ROLL DISENGAGE push-switch to test the proper operation of the differential servo disengage relay. If the relay is operating properly the differential servo should become disconnected and return to a streamline position due to the satisfactory operation of the centering spring in the servo unit.
- 5.3.20 Select the TEST SELECTOR A to the "SL" position. This removes all signal inputs to the roll axis bridge and ensures that there are no spurious signals being applied to the servo amplifier. It is necessary to ensure streamlining at this point preparatory to checking the integrator.
- 5.3.21 Select the TEST SELECTOR A to the "INTEG" position. The SURFACE INDICATOR should deflect off scale as a voltage applied to the SURFACE INDICATOR representing the final deflection will not be reached until _____ seconds after the HP-INTEGRATOR push-switch is pressed. If the integrator is operating satisfactorily the control surface should slowly return to its predetermined position which will be indicated by a GOOD indication on the SURFACE INDICATOR.
- 5.3.22 Select the TEST SELECTOR A to the "TO B" position. This automatically transfers all functions from the TEST SELECTOR A to the TEST SELECTOR B. If the Test Set was originally set up properly the TEST SELECTOR B should be at its first "SL" position. Check that the streamlining is correct by ensuring that the SURFACE INDICATOR reads zero. If not, rotate the ZERO LEFT TRIM control until it does.
- 5.3.23 Select the TEST SELECTOR B to the "g sa" position. In this position the produce term consisting of an aileron position and pitch rate is checked. This is done by deflecting the aileron a pre-determined amount and applying a test signal corresponding to pitch rate to the aileron position potentiometer.



5.3.23 (continued)

The resulting signal applied to the bridge is therefore a combination of pitch rate and aileron position and the SURFACE INDICATOR should read GOOD. If a "bad" reading is obtained it is most likely due to a fault in the yaw axis bridge or the aileron position potentiometer as both pitch rate and aileron position have been previously tested.

- 5.3.24 Select the DIRECTION switch to the " - " position. This should cause the rudder to deflect in the opposite direction, and symmetrical operation of the rudder will be indicated by a GOOD reading on the SURFACE INDICATOR. This test need not be repeated for all subsequent tests as the rudder axis will be on portions common to the servo amplifier, and if the amplifier and control surface linkage is operating properly in both directions for one test it will obviously do the same for all.
- 5.3.25 Select the TEST SELECTOR B successively to the RUDDER NORMAL "r", "ay", "sa" and "HP" positions and observe that GOOD readings are obtained on the SURFACE INDICATOR.
- 5.3.26 Connect the Pitot-Static Test Set to the pitot head mounted on the fin of the aircraft.
- 5.3.27 Select the TEST SELECTOR B successively to the RUDDER EMERGENCY "SL", "r", "ay", "sa" and "HP" positions and with a differential pressure applied by the Pitot-Static Test Set as outlined in Table I for each test position, observe that GOOD readings are obtained on the SURFACE INDICATOR.

TABLE I

Position of Test Selector B	q c	Altitudes	Mach. No.
Rudder Emerg. "SL"			
Rudder Emerg. "r"			
Rudder Emerg. "ay"			
Rudder Emerg. "a"			
Rudder Emerg. "HP"			

- 5.3.28 Select the TEST SELECTOR B to the PITCH GEAR DOWN position and engage the Damper by pressing the ENGAGE push-switch. The pointer of the SURFACE INDICATOR should deflect off the scale and gradually return to the GOOD portion of the scale.



5.3.28 (continued)

The fact that the pointer returns slowly to GOOD indicates that the faders in the pitch axis are operating. When the TEST SELECTOR B is selected to the PITCH GEAR DOWN position, a signal is applied to the "CSS" input of the Damper Amplifier Calibrator. The mode of operation is switched to "Landing gear down" and satisfactory operation of the fader motor should be indicated by the SURFACE INDICATOR pointer deflecting to the red or "bad" portion of the scale and gradually returning to the GOOD portion. The speed of return is associated with the speed of the fader.

- 5.3.29 Select the TEST SELECTOR B to the ROLL GEAR DOWN position. A good reading should be obtained on the SURFACE INDICATOR indicating proper operation of the differential and parallel servos.
- 5.3.30 Connect the Pitot-Static Test Set to the pitot head mounted on the nose boom of the aircraft and apply a differential pressure of _____ to the normal pitot-static system.
- 5.3.31 Select the TEST SELECTOR B to the "q c NORMAL" position. A previously selected input is applied to the Damper bridge and the proper bucking voltage applied. The "q c" scheduler runs and if its operation is satisfactory it will stop at such position that the deviation on the SURFACE INDICATOR will be zero or GOOD. Therefore, a GOOD indication on the SURFACE INDICATOR means that the normal Damper mode "q c" transducer is serviceable and within tolerance.
- 5.3.32 Connect the Pitot-Static Test Set to the pitot head mounted on the fin of the aircraft.
- 5.3.33 Select the TEST SELECTOR B to the "ALT" position. Using the Pitot-Static Test Set apply a pressure corresponding to _____ feet of altitude to the pitot-static system. If a differential pressure of _____ lbs. is applied to the pitot-static system as well, the "q c" scheduler will run, and if its operation is satisfactory it will stop at such a position that the deviation on the SURFACE INDICATOR will be zero or GOOD. Therefore a GOOD indication on the SURFACE INDICATOR means that the altitude scheduler transducer is serviceable as the "q c" scheduler was previously tested.

NOTE

If good readings are obtained on each of the above steps the aircraft Damper System including the Damper Amplifier Calibrator, the servo amplifiers and the control surface linkage will be serviceable. Should a "bad" reading be obtained on any one of the above it is likely that there is an error in the calibration of one input circuit.

Note (continued)

If the deflection is off scale it is possible that one of the gain controls or scheduling potentiometers in the Damper Amplifier Calibrator is "open". The position of the TEST SELECTOR A and B will locate the faulty circuit. Should the deflection be only slightly out of the GOOD region it may be possible to adjust the offending potentiometer on the Amplifier Calibrator, (care should be taken that it is a gain potentiometer and not a "q c" potentiometer at fault. Faults in any of the other portions of the Damper System will normally be characterized by a series of "no-go" indications and the use of the UG 6005A-1 Damper Auxiliary Test Set will be required in order to isolate the faulty component. The operation of the sensors is tested with the aid of the VTVM which is part of the UG 6005A-1 Damper Auxiliary Test Set. The procedure is as follows:

- 5.3.34 With reference to Figure 16 connect the UG 6005A-1 Damper Auxiliary Test Set to the UG 6004A-1 Damper Test Set and the aircraft in the following manner:
- (a) Connect cable P5 from the Damper Auxiliary Test Set to J28 on the Damper Test Set.
 - (b) Connect cable P7A from the Damper Auxiliary Test Set to connector R1087/5 that was removed from the Damper Amplifier Calibrator.
 - (c) Connect cable P7B from the Damper Auxiliary Test Set to connector R1087/8 that was removed from the Damper Amplifier Calibrator.
 - (d) Remove connector R1087/6 from the Damper Amplifier Calibrator and connect in its place cable P6 from the Damper Auxiliary Test Set.
- 5.3.35 Turn the VTVM located on the Damper Auxiliary Test Set "on" by selecting the INTERNAL-EXTERNAL switch on the UG 6004A-1 Damper Test Set, to the EXTERNAL position.
- 5.3.36 Select the VTVM INPUT switch on the Auxiliary Test Set to measure voltages from the sensors indicated. All the readings should be below _____ volts but not zero with the exception of the "CSS" and "δ α" positions. The readings on the "CSS" and "δ α" positions will depend on force applied to the control column handgrip and on the aileron surface position respectively. A further check on the aileron position potentiometer is obtained by selecting the DIRECTION switch on the Damper Test Set to the "-" position, causing the aileron to deflect in the opposite direction. The VTVM reading on the Auxiliary Test Set will drop to zero and rise to the same value as for the "+" position. "CSS" can be checked qualitatively from the pilot's cockpit by applying a force on the control column handgrip and observing the



5.3.36 (continued)

deflection of the VTVM. If a quantitative check of the stick force is required it will be necessary to use a spring balance to apply a measured force on the control column handgrip and to observe the deflection of the VTVM.

- 5.3.37 The operation of the air data transducers may be further checked by applying "q c" signals to the pitot-static tube mounted on the fin of the aircraft and measuring the voltage output from the "q c" transducer. Table 2, lists values of pressures and the corresponding VTVM readings.

TABLE 2

ALTITUDE	MACH NO.	q c	VTVM READINGS

- 5.3.38 Select the VTVM INPUT switch to the "HML" position and apply a differential pressure of _____ lbs to the pitot-static head mounted on the fin of the aircraft. A reading of _____ volts should be read on the VTVM.
- 5.3.39 Surface deflection other than those preselected on the Damper Test Set may be obtained by using the MODE SELECT switch on the Auxiliary Test Set. When this switch is selected to the MANUAL position, manually adjustable voltages can be applied to each of the inputs selected by the TEST SELECTORS A and B on the Damper Test Set as required. These input voltages are adjusted by means of the INPUT ADJUST CONTROL on the Auxiliary Test Set. Values of "q c" for the normal axis scheduler can be adjusted by means of the "q c" ADJUST control on the Auxiliary Test Set. Where manual voltages are applied the Damper System it is generally desirable to measure control surface deflection rather than deviation. Deflection can be measured by selecting the DEVIATION/DEFLECTION switch on the Auxiliary Test Set to the DEFLECTION position. This will enable the control surface deflection to be measured directly on the SURFACE INDICATOR located on the Damper Test Set. (Note that the deviation and deflection readings are accurate only when the surfaces have been previously streamlined).

NOTE

In order to prevent excessive signals being applied to the Damper bridge when the MODE SELECT switch on the Auxiliary Test Set is selected to the MANUAL position it is necessary to select the INPUT ADJUST control on the Auxiliary Test Set to the MANUAL START position before a signal is applied. When the INPUT ADJUST control is selected to the MANUAL START position a relay is closed which allows this "manual adjust" signal to be applied to the Damper bridge. This is a safety feature to protect personnel working either in the pilot's cockpit, or around the control surfaces, from receiving blows from the control column or the control surface, should the test technician accidentally switch the MODE SELECT switch to the MANUAL position when the INPUT ADJUST control is set for a large signal.

- 5.3.40 Select the VTVM INPUT switch on the Auxiliary Test Set to the LINE position to read the value of the 400 cycle input voltages to the Damper.
- 5.3.41 When the VTVM INPUT switch on the Auxiliary Test Set is selected to the EXTERNAL position the input to the VTVM on the Auxiliary Test Set is connected to the VTVM INPUT jacks (J1, J2, & J3) located immediately below the VTVM INPUT switch. The equipment can then be used as a conventional VTVM for measuring voltages at various points in the Damper circuit. The voltage range of the VTVM can be selected by means of the VTVM RANGE switch located on the Auxiliary Test Set.



5.4 Location of Faulty Components

The procedure to be followed in the event of a "no-go" reading on any one of the First Line tests is as follows in order of switch positions.

Pitch Axis (Elevators)

5.4.1 SL (Streamline)

Failure to streamline within specified rotation of the TRIM control (\pm _____ %) may be caused by a malfunction of one or more of the following:

- (a) Left or right elevator differential servo.
- (b) Elevator parallel servo.
- (c) A signal in the elevator differential or parallel servo bridge
- (d) Elevator differential servo amplifier.
- (e) Elevator parallel servo amplifier.
- (f) Elevator differential servo feed-back or the elevator parallel servo feed-back.
- (g) Elevator position potentiometers.

Checks should be made in the following order.

5.4.1.1 Select the ELEVATOR/AILERON switch on the Damper Test Set to the "L" and "R" positions. If both readings are out of tolerance check the differential servo bridge and the parallel servo bridge for a signal, check the parallel servo, the parallel servo amplifier and the parallel servo feed-back. If the reading for the right differential is GOOD and the left one is at fault check the left differential servo, the left surface position potentiometers, the left differential servo feed-back and the left differential servo amplifier.

5.4.1.2 The following applies when the left reading is at fault.

- (a) To check the surface position potentiometers disengage the Damper by pressing the "P D" push-switch on the Damper Test Set. This centres the differential servo and the SURFACE INDICATOR on the Damper Test Set should readily be made to read zero by the use of the ZERO LEFT TRIM control on the Damper Test Set if the surface potentiometer is good. If the SURFACE INDICATOR cannot be made to read zero then the potentiometer is faulty or misadjusted.



- (b) The positional feed-back can be checked by connecting test leads from J1 and J2 of the Auxiliary Test Set to J27 and J28 of the Damper Amplifier Calibrator and taking a reading on the VTVM on the Auxiliary test Set. This reading should be below _____ volts, otherwise the postional feed-back is faulty.
- (c) Check the differential servo amplifier by selecting the SERVO SELECTOR switch on Auxiliary TestSet to the ELEVATOR L position and connecting test leads from J1 and J2 of the Auxiliary Test Set to J27 and J80 on the Damper Amplifier Calibrator. The VTVM on the Auxiliary Test Set should read zero and the SERVO CONTROL meters on the same Test Set should read within _____ milliamps and less than _____ milliamps otherwise the differential servo amplifier is faulty.
- (d) If the surface potentiometer, the positional feed-back and the servo amplifier are satisfactory then it is likely that the differential servo is faulty. A further check on the differential servo is to engage the Damper by pressing the DAMPER ENGAGE push-switch on the Damper Test Set and since the positional feed-back, the surface potentiometer, and the servo amplifier are good, a residual signal will appear at the input to the amplifier when the servo has stopped. This will give an unbalance current into the servo control valve which will neutralize any unequal pressure built up in the faulty servo valve.

5.4.1.3 The following applies when both reachings give a "no-go" indication.

- (a) A residual signal in the bridge can be checked by connecting test leads from J1 and J2 of the Auxiliary Test Set to J28 and J80 on the Damper Amplifier Calibrator for the differential servos, and J35 and J8 for the parallel servo. The reading obtained on the VTVM on the Auxiliary Test Set should be less than _____ volts otherwise the integrator may be faulty.



- 5.4.1.4 If there is a residual signal in the differential servo bridge proceed as follows:
- (a) Connect test leads from J1 and J2 on the Auxiliary Test Set to J31 and J32 on the Damper Amplifier Calibrator. The VTVM on the Auxiliary Test Set will indicate any residual signal from the bridge amplifier. If no signal is present from the bridge amplifier move the test leads from J31 and J32 on the Amplifier Calibrator to J62 and J65 of the same unit. If a signal is present, there is a residual trim signal in the bridge and it is quite likely that the trim switching amplifier, trim motor or trim circuitry is faulty.
 - (b) Move the test leads from J62 and J65 of the Amplifier Calibrator to J32 and J80 of the same unit. Any signal here is due to either faulty high pass or amplifier. To eliminate high pass move the test leads to J32 and J70 of the Amplifier Calibrator and obtain a reading less than _____ volts on the VTVM on the Auxiliary Test Set if high pass is working properly.
- 5.4.1.5 The parallel servo positional feedback can be checked as follows:
- (a) Select the TEST SELECTOR A on the Damper Test Set to the "TO B" position and the TEST SELECTOR B of the same Test Set to the PITCH GEAR DOWN position.
 - (b) Select on the Auxiliary Test Set the MODE SELECT switch to the MANUAL position, the SURFACE INDICATOR SELECT switch to the DEFLECTION position and adjust the INPUT ADJUST control until the SURFACE INDICATOR on the Damper Test Set read zero.
 - (c) Measure the voltage across the servo feedback by connecting test leads from J1 and J2 of the Auxiliary Test Set to J34 and J35 of the Damper Amplifier Calibrator and taking a reading on the VTVM on the Auxiliary Test Set. If the voltage is not less than _____ volts the positional feedback is faulty.



5.4.2 CSS (Control Stick Steering)

- 5.4.2.1 A "no-go" indication on "CSS" may be the result of a faulty gain adjustment or an open bridge. The magnitude of error will be indicated by the SURFACE INDICATOR on the Damper Test Set. If it is off scale there is probably an open circuit in the bridge and if in the "no-go" portion a gain adjustment is indicated, check as follows:
- (a) Select the TEST SELECTOR A on the Damper Test Set to the "n" position and if the SURFACE INDICATOR on the Damper Test Set reads GOOD a manual gain adjustment is probably necessary.
 - (b) Select the TEST SELECTOR A on the Damper Test Set to the "CSS" position, connect test leads from J1 and J2 on the Auxiliary Test Set to J66 and J67 on the Damper Amplifier Calibrator and adjust until the VTVM on the Auxiliary Test Set reads _____ volts.
 - (c) If a "no-go" reading is obtained with the TEST SELECTOR A selected to the "n" position, select it to the "q" position and if this reading is "no-go" also, the "q c" scheduler is probably faulty.
 - (d) If a GOOD reading is obtained with the TEST SELECTOR A in the "q" position the stick force transducer and normal acceleration bridge amplifier is probably faulty.
 - (e) Select the TEST SELECTOR A on the Damper Test Set to the "CSS" position, connect test leads from J1 and J2 on the Auxiliary Test Set to J31 and J32 on the Damper Amplifier Calibrator. The VTVM on the Auxiliary Test Set will read _____ volts if the amplifier is good.
 - (f) Move the test leads from J31 and J32 on the Amplifier Calibrator to J28 and J32 on the same unit. The VTVM on the Auxiliary Test Set should read _____ volts if the "q c" scheduling potentiometer setting is correct.
 - (g) A "no-go" reading with the TEST SELECTOR A on the Damper Test Set in the "q" "n" and "CSS" positions may indicate that there is an incorrect adjustment of the differential ratio potentiometer.

5.4.3 n (Normal Acceleration)

5.4.3.1 Since the "CSS" position is satisfactory, the bridge amplifier and the scheduler are assumed satisfactory, this leaves only the manual adjustment on "n" to be checked as follows:

- (a) Select the TEST SELECTOR A on the Damper Test Set to the "n" position and connect test leads from J1 and J2 on the Auxiliary Test Set to J62 and J67 on the Damper Amplifier Calibrator. The VTVM on the Auxiliary Test Set should read _____ volts.

5.4.4 q (Pitch Rate)

5.4.4.1 With the TEST SELECTOR A on the Damper Test Set selected to the "q" position take readings on the VTVM of the Auxiliary Test Set with test leads connected to J1 and J2 on the Auxiliary Test Set and to the following on the Damper Amplifier Calibrator.

- (a) J69 and J80 the VTVM should read _____ volts if the amplifier is satisfactory.
- (b) J70 and J80 the VTVM should read _____ volts if the amplifier and the "q c" scheduling are satisfactory.
- (c) J32 and J70 the VTVM should read zero if the high-pass is working satisfactory.
- (d) J28 and J80 should read the same as J32 and J80 otherwise there is some residual signal from the "CSS" and "n" bridge amplifier into the bridge which appears across the fader potentiometer and adds to the pitch rate signal.

5.4.5 q h (High Pass)

5.4.5.1 Streamline the surface again by pressing the SL push-switch on the Damper Test Set.

5.4.5.2 Connect test leads from J1 and J2 on the Auxiliary Test Set to J32 and J80 on the Damper Amplifier Calibrator.

5.4.5.3 Press the HP-INTEG. push-switch on the Damper Test Set and watch the voltage indicated on the VTVM of the Auxiliary Test Set decrease from _____ volts to between _____ and _____ volts if the high pass is operating satisfactory.



5.4.5.3 (continued)

A reading above or below this value indicates that a timing adjustment is needed. If there is no action at all, the high pass circuit is faulty.

5.4.6 P D (Pitch Disengage)

- 5.4.6.1 If the SURFACE INDICATOR on the Damper Test Set reads 5° after disengagement the differential servo has not re-centred. Select to the right differential servo by selecting the ELEVATOR/AILERON switch on the Damper Test Set to the "R" position and check it. If the reading indicated by the SURFACE INDICATOR continues to rise the parallel servo has not released which indicates a faulty parallel servo disengage unit.

5.4.7 INTEG (Integrator)

- 5.4.7.1 Connect test leads from J1 and J2 on the Auxiliary Test Set to J63 and J80 on the Damper Amplifier Calibrator.
- 5.4.7.2 Streamline the surface by pressing the "SL" push-switch on the Damper Test Set.
- 5.4.7.3 Press the HP-INTEG push-switch on the Damper Test Set and watch the VTVM on the Auxiliary Test Set increase from zero to between _____ and _____ volts if the integrator timing is satisfactory.

Roll Axis (Aileron)5.4.8 SL (Streamline)

Failure to streamline within the specified rotation of the TRIM control (\pm %) may be caused by a malfunction of one or more of the following:

- (a) Left or right aileron differential servo
- (b) Aileron parallel servo
- (c) A signal in the aileron differential on parallel servo bridge.
- (d) Aileron parallel servo amplifier.
- (e) Aileron differential servo feed-back of the aileron parallel or servo feed-back.
- (g) Aileron position potentiometers.

Checks should be made in the following order:

- 5.4.8.1 Select the ELEVATOR/AILERON switch on the Damper Test Set to the "L" and "R" positions. If both readings are out of tolerance check the differential servo bridge and the parallel servo bridge for a signal,



5.4.8.1 (continued)

check the parallel servo amplifier and the parallel servo feed-back. If the reading for the right differential is good and the left one is at fault check the left differential servo, the left surface position potentiometer, the left differential servo feedback, and the left differential servo amplifier.

5.4.8.2 The following applies when the left reading is at fault:

- (a) To check the surface position potentiometers disengage the Damper by pressing the P.D. push-switch on the Damper Test Set. This centres the differential servo and the SURFACE INDICATOR on the Damper Test Set should be readily made to read zero by the use of the ZERO LEFT TRIM control on the Damper Test Set, if the surface potentiometer is good.

If the SURFACE INDICATOR cannot be made to read zero then the potentiometer is faulty or misadjusted.

- (b) The positional feed-back can be checked by connecting test leads from J1 and J2 on the Auxiliary Test Set to J19 and J20 on the Damper Amplifier Calibrator and taking a reading on the VTVM on the Auxiliary Test Set. This reading should be below ___ volts, otherwise the positional feedback is faulty.
- (c) Check the differential servo amplifier by selecting the SERVO SELECTOR switch on the Auxiliary Test Set to the AILERON L position and connect test leads from J1 and J2 of the Auxiliary Test Set to J19 and J80 on the Damper Amplifier Calibrator. The VTVM on the Auxiliary Test Set should read zero and the SERVO CONTROL CURRENT meters on the same TEST SET should read within _____ milliamps and less than _____ milliamps otherwise the differential servo amplifier is faulty.
- (d) If the surface potentiometer, the positional feedback and the servo amplifier are satisfactory then it is likely that the differential servo is faulty. A further check on the differential servo is to engage the Damper by pressing the DAMPER ENGAGE push-switch on the Damper Test Set and since the positional feedback, the surface potentiometer and the servo amplifier are good a residual signal will appear at the input to the amplifier when the servo has stopped. This will give an unbalance current into the servo control



(d) (continued)

valve which will neutralize any unequal pressure built up in the faulty servo valve.

5.4.8.3 The following applies when both readings give a "no-go" indication.

(a) A residual signal in the bridge can be checked by connecting test leads from J1 and J2 on the Auxiliary Test Set to J20 and J80 on the Damper Amplifier Calibrator for the differential servo, and J59 and J80 for the parallel servo. The reading obtained on the VTVM on the Auxiliary Test Set should be less than _____ volts.

5.4.8.4 If there is a residual signal in the differential servo bridge proceed as follows:

(a) Connect test leads from J1 and J2 on the Auxiliary Test Set to J56 and J80 on the Damper Amplifier Calibrator. The VTVM on the Auxiliary Test Set will indicate any residual signal. If no signal is present move the test leads from J56 and J80 on the Amplifier Calibrator to J25 and J55 of the same unit. A signal here indicates there is trim voltage in the bridge and therefore a faulty trim circuit.

(b) Move the test leads from J25 and J55 on the Amplifier Calibrator to J57 and J80 of the same unit. Any signal here indicates a faulty Roll Bridge Amplifier.

5.4.8.5 The parallel servo positional feed-back can be checked as follows:

(a) Select the TEST SELECTOR A on the Damper Test Set to the "TO B" position and the TEST SELECTOR B on the Test Set to the ROLL GEAR DOWN position.

(b) Select on the Auxiliary Test Set the MODE SELECT switch to the MANUAL position, the SURFACE INDICATOR SELECT switch to the DEFLECTION position and adjust the INPUT ADJUST control until the SURFACE INDICATOR on the Damper Test Set reads zero.



- (c) Measure the voltage across the servo feed-back by connecting test leads from J1 and J2 on the Auxiliary Test Set to J58 and J59 on the Damper Amplifier Calibrator and taking a reading on the VTVM on the Auxiliary Test Set. If the voltage is not less than _____ volts the positional feed-back is faulty.

5.4.9 CSS (Control Stick Steering)

5.4.9.1 A "no-go" indication on "CSS" may be the result of a faulty amplifier or ratio adjustment. The magnitude of error will be indicated by the SURFACE INDICATOR on the Damper Test Set. If it is off scale there is probably an open circuit in the bridge and if in the "no-go" portion a gain adjustment is indicated, check as follows:

- (a) Select the TEST SELECTOR A on the Damper Test Set to the "P" position and if the SURFACE INDICATOR on the Damper Test Set reads GOOD a manual adjustment or a "q c" adjustment is required.
- (b) Connect test leads from J1 and J2 on the Auxiliary Test Set to J24 and J80 on the Damper Amplifier Calibrator. The VTVM on the Auxiliary Test Set should read _____ volts if the manual adjustment is good.
- (c) Move the test lead from J25 on the Amplifier Calibrator to J23 on the same unit. The VTVM should read _____ volts if the manual and the "q c" setting is good.
- (d) Move the test leads to J57 and J80 on the Amplifier Calibrator. The VTVM should read _____ volts if the bridge amplifier is satisfactory.

5.4.10 P (Roll Rate)

5.4.10.1 If the "CSS" test was satisfactory the bridge ratio adjustment and bridge amplifier are satisfactory. Check the manual adjustment as follows:

- (a) Connect test leads from J1 and J2 on the Auxiliary Test Set to J22 and J23 on the Damper Amplifier Calibrator. The VTVM on the Auxiliary Test Set should read _____ volts if the manual adjustment is correct.



- (b) Move the test leads from J22 and J23 on the Amplifier Calibrator to J23 and J56 of the same unit. The VTVM should read ___ volts if the "q c" is correct.

5.4.11 RD (Roll Disengage)

- 5.4.11.1- If the SURFACE INDICATOR on the Damper Test Set reads 5° after disengagement, the differential servo has not re-centred. Select to the right differential servo by selecting the ELEVATOR/AILERON switch on the Damper Test Set to the "R" position and check it. If the reading indicated by the SURFACE INDICATOR continues to rise the parallel servo has not released which indicates a faulty parallel servo disengage unit.

5.4.12 INTEG. (Integrator)

- 5.4.12.1 Connect test leads from J1 and J2 on the Auxiliary Test Set to J59 and J80 on the Damper Amplifier Calibrator.
- 5.4.12.2 Streamline the surface by pressing the SL push-switch on the Damper Test Set.
- 5.4.12.3 Press the HP-INTEG push-switch on the Damper Test Set and watch the VTVM on the Auxiliary Test Set increase from zero to between ___ volts and ___ volts if the integrator timing is satisfactory.

Normal Rudder Axis

5.4.13 SL (Streamline)

- 5.4.13.1 Carry out the following checks.
- (a) Check for zero bridge voltage by connecting test leads from J1 and J2 on the Auxiliary Test Set to J11 and J80 on the Damper Auxiliary Calibrator. The VTVM on the Auxiliary Test Set should read zero.
- (b) If the bridge voltage is not zero, move the test leads to J15 and J16 on the Amplifier Calibrator to check the high pass output. The VTVM on the Auxiliary Test Set should read zero.
- (c) If the bridge voltage is zero, select the Damper POWER ON-OFF switch in the pilot's cockpit to first the OFF then the ON position to disengage the Damper. If the SURFACE INDICATOR on the Damper Test Set does not read zero the surface potentiometer is misadjusted.



- (d) If the surface potentiometer output is zero move the test leads from J15 and J16 on the Damper Amplifier Calibrator to J10 and J11 on the same unit. The VTVM on the Auxiliary Test Set should read less than ___ volts if the servo feed-back is properly adjusted.
- (e) Select the SERVO SELECTOR switch on the Auxiliary Test Set to the RUD. NOR. position and move the test leads to J10 and J80 on the Amplifier Calibrator. The VTVM on the Auxiliary Test Set should read zero and the SERVO CONTROL CURRENT meters on the same Test Set should read within ___ milliamps of each other and less than ___ milliamps or a faulty servo amplifier is indicated.

If all the above checks prove satisfactory the servo unit must be faulty.

5.4.14 q δ a (Pitch Rate Times Aileron Position)

- 5.4.14.1 Where a "no-go" reading has been obtained with the TEST SELECTOR B on the Damper Test Set selected to the "q δ a" position carry out the following:
 - (a) Select the TEST SELECTOR B on the Damper Test Set to the "Y" position. If a GOOD reading is obtained on the SURFACE INDICATOR on the Damper Test Set the fault lies with either the EG153A-1 amplifier, the aileron potentiometer or the "q c" adjust potentiometer. If a "no-go" reading is obtained a faulty ratio adjustment potentiometer is indicated. Check this by switching the TEST SELECTOR B to the "a y" position and obtaining a "no-go" indication.
 - (b) Check the EG153A-1 bridge amplifier and the aileron potentiometer by connecting test leads from J1 and J2 on the Auxiliary Test Set to J9 and J13 on the Damper Amplifier Calibrator. The VTVM on the Auxiliary Test Set should read ___ volts if good.
 - (c) Check the "q c" setting by moving the test leads from J9 and J13 on the Amplifier Calibrator to J11 and J13 on the same unit. The VTVM on the Auxiliary Test Set should read ___ volts if correct.

5.4.15 r (Yaw Rate)

5.4.15.1 Connect test leads from J1 and J2 on the Auxiliary Test Set to J18 and J80 on the Damper Amplifier Calibrator. The VTVM on the Auxiliary Test Set should read _____ volts if the "q c" setting is correct.

5.4.16 a y (Lateral Acceleration)

5.4.16.1 Connect test leads from J1 and J2 on the Auxiliary Test Set to J13 and J15 on the Damper Amplifier Calibrator. The VTVM on the Auxiliary Test Set should read _____ volts.

5.4.16.2 An incorrect reading may also be caused by the low speed switch not operating and therefore high-passing a portion of the "a y" output. Check by connecting test leads from J1 and J2 on the Auxiliary Test Set to J19 on the Damper Test Set and J15 on the Damper Amplifier Calibrator. The VTVM on the Auxiliary Test Set should read zero volts.

5.4.17 a (Aileron Position)

5.4.17.1 Connect test leads from J1 and J2 on the Auxiliary Test Set to J16 and J18 on the Damper Amplifier Calibrator. The VTVM on the Auxiliary Test Set should read _____ volts.

5.4.18 HP (High Pass)

5.4.18.1 Connect test leads from J1 and J2 on the Auxiliary Test Set to J15 and J80 on the Damper Amplifier Calibrator. The VTVM on the Auxiliary Test Set should read _____ volts then reduce to _____ volts if the high pass is operating properly.

Emergency Rudder Axis5.4.19 SL (Streamline)

5.4.19.1 Carry out the following checks:

- (a) Check for zero bridge voltage by connecting test leads from J1 and J2 on the Auxiliary Test Set to J47 and J80 on the Damper Amplifier Calibrator. The VTVM on the Auxiliary Test set should read zero.



- (b) If the bridge voltage is not zero move the test leads to J49 and J50 on the Amplifier Calibrator to check the high pass output. The VTVM on the Auxiliary Test Set should read zero.
- (c) If the bridge voltage is zero select the DAMPER POWER ON-OFF switch in the pilot's cockpit to first the OFF then the ON position to disengage the Damper. If the SURFACE INDICATOR on the Damper Test Set does not read zero the surface potentiometer is misadjusted.
- (d) If the surface potentiometer output is zero move the test leads from J49 and J50 on the Damper Amplifier Calibrator to J46 and J47 on the same unit. The VTVM on the Auxiliary Test Set should read less than _____ volts if the servo feed-back is properly adjusted.
- (e) Select the SERVO SELECTOR switch on the Auxiliary Test Set to the RUD. EMG. position and move the test leads to J46 and J80 on the Amplifier Calibrator. The VTVM on the Auxiliary Test Set should read zero and the SERVO CONTROL CURRENT meters on the same Test Set should read within _____ milliamps of each other and less than _____ milliamps or a faulty servo amplifier is indicated.
- (f) If the above checks prove satisfactory the servo unit must be faulty. To establish if the servo is faulty, press the SERVO TEST switch on the Auxiliary Test Set and note the reading on the SERVO CONTROL CURRENT meters. If there is no change in the currents the EG113 amplifier is faulty and if the currents fall within tolerance, the servo unit is at fault.

5.4.20 r (Yaw Rate)

- 5.4.20.1 Connect test leads from J1 and J2 on the Auxiliary Test Set to J52 and J80 on the Damper Amplifier Calibrator. The VTVM on the Auxiliary Test Set should read _____ volts if the "q c" setting is correct.

5.4.21 a y (Lateral Acceleration)

- 5.4.21.1 Connect test leads from J1 and J2 on the Auxiliary Test Set to J47 and J49 on the Damper Amplifier Calibrator. The VTVM on the Auxiliary Test Set should read _____ volts.



SECRET

70/MAINT 13/1

5.4.21.2 An incorrect reading may also be caused by the low speed switch not operating and therefore high-passing a portion of the "a y" output. Check by connecting test leads from J1 and J2 on the Auxiliary Test Set to J20 on the Damper Test Set and J49 on the Damper Amplifier Calibrator. The VTVM on the Auxiliary Test Set should read zero.

5.4.22 δ a (Aileron Position)

5.4.22.1 Connect test leads from J1 and J2 on the Auxiliary Test Set to J50 and J52 on the Damper Amplifier Calibrator. The VTVM on the Auxiliary Test Set should read _____ volts.

5.4.23 HP (High Pass)

5.4.23.1 Connect test leads from J1 and J2 on the Auxiliary Test Set to J49 and J80 on the Damper Amplifier Calibrator. The VTVM on the Auxiliary Test Set should read _____ volts then reduce to _____ volts if the high-pass is operating properly.

5.4.24 PITCH GEAR DOWN

5.4.24.1 Check that the Damper is engaged by pressing the DAMPER ENGAGE push-switch on the Damper Test Set. Connect test leads from J1 and J2 on the Auxiliary Test Set to J35 and J63 on the Damper Amplifier Calibrator. The VTVM on the Auxiliary Test Set should read _____ volts.

5.4.25 ROLL GEAR DOWN

5.4.25.1 Connect test leads from J1 and J2 on the Auxiliary Test Set to J59 and J80 on the Damper Amplifier Calibrator. The VTVM on the Auxiliary Test Set should read _____ volts.

5.4.26 q c NCR. (Normal)

5.4.26.1 Connect test leads from J1 and J2 on the Auxiliary Test Set to J1 and J2 on the Damper Test Set. Connect the MB-1 Pitot-Static Test Set to the pitot-head mounted on the nose boom of the aircraft and apply a differential pressure of _____ PSF. The VTVM on the Auxiliary Test Set should read _____ volts.

5.4.27 ALT. (Altitude)

5.4.27.1 Connect test leads from J1 and J2 on the Auxiliary Test Set to J64 and J80 on the Damper Amplifier Calibrator.



5.4.27.1 (continued)

The VTVM on the Auxiliary Test Set should read _____ volts otherwise the altitude or "q c" setting is incorrect.

NOTE

When the operation of the "q c" scheduler is suspected through a series of "no-go" readings proceed as follows:

- (a) Connect test leads from J1 and J2 on the Auxiliary Test Set to J1 on Dampener Test Set and ground.
- (b) Select on the Auxiliary Test Set the VTVM INPUT switch to the EXT. position, the MODE SELECT switch to the MAN. "q c" x 10 position, and the "q c" ADJUST PSF switch to the _____ PSF position. The VTVM should read _____ volts if the "q c" scheduler is good.



6. SECOND LINE TESTING

Second line tests on the Damper System will be concerned principally with the verification of faults discovered in the equipment during the First Line tests. When a suspected component has been discovered on the aircraft it is removed and replaced with a known good one. The suspected component is then subjected to further tests on the UG 6003A-1 Damper Test Stand and/or the UG 6002A-1 Rate Table.

The test equipment required to carry out Second line testing is as follows:

- (a) UG 6003A-1 Damper Test Stand
- (b) UG 6002A-1 Rate Table
- (c) UG 6004A-1 Damper Test Set
- (d) UG 6005A-1 Damper Auxiliary Test Set
- (e) MB-1 Pitot-Static Test Set
- (f) UG 6006A-1 "G" Limiter Test Set

Following are the procedures for using the Second line equipment.

6.1 UG 6003A-1 Damper Test Stand (Reference Figure 14)

6.1.1 Preparation for Test

6.1.1.1 With all power switches in the OFF position connect the UG 6005A-1 Damper Test Set and the UG 6005A-1 Damper Auxiliary Test Set to the UG 6003A-1 Damper Test Stand as follows:-

- (a) Cable P29 and P30 from the Damper Test Set to J _____ and J _____ on the Junction Box of the Damper Test Stand.
- (b) Cable P30 from the Damper Test Set to J _____ on the Hydraulic Simulator on the Damper Test Stand.
- (c) Cable P6, P7A and P7B from the Damper Auxiliary Test Set to P__ P__ and P__ on the Test Stand.
- (d) Cable P5 from the Damper Auxiliary Test Set to P28 on the Damper Test Set.

6.1.1.2 Select on the UG 6004A-1 Damper Test Set the EXTERNAL-INTERNAL switch to the INTERNAL position, the ZERO TRIM controls to their centre position and then the DIRECTION, ELEVATOR/AILERON and TEST SELECTOR switches to their full left position.



SECRET

70/MAINT 13/1

- 6.1.1.3 Select the POWER switch on the Damper Function Selector, located on the Damper Test Stand to the ON position.
- 6.1.1.4 Select the A-C POWER switch on the Damper Test Set to the ON position, the D-C POWER switch to the TEST STAND position and then ensure that the POWER ON lights are illuminated.
- 6.1.1.5 Adjust the D-C voltage by pressing the D-C PRESS TO ADJUST push-switch on the Damper Test Set and rotating the D-C ADJUST CONTROL on the Hydraulic Simulator, located on the Damper Test Stand until the pointer of the SURFACE INDICATOR, located on the Damper Test Set is deflected to the D-C VOLTAGE ADJUST line.
- 6.1.1.6 Obtain a simulated control surface streamline condition by selecting the TEST SELECTOR A on the Damper Test Set to the first ELEVATOR SL position. Adjust the ELEVATOR AXIS DIFFERENTIAL SERVO control on the Hydraulic Simulator to obtain a minimum reading on the SERVO CONTROL CURRENT meters on the Damper Auxiliary Test Set. This corresponds to the control surface moving to its commanded position, and the feed-back from the servo position transformer being fed into the EG 113 servo amplifier and in turn nulling out the command signal and minimizing the servo current. The SURFACE INDICATOR on the Damper Test Set should now read GOOD.
- 6.1.1.7 Select on the UG 6004A-1 Damper Test Set the ELEVATOR/AILERON switch to the "R" position and providing the SURFACE INDICATOR does not read too far off zero adjust the ZERO RIGHT TRIM until it does read zero. Should the right elevator be off streamline by a large amount a malfunction in the Servo Amplifier in the Damper Amplifier Calibrator is indicated. (See sub para 5.3.5)
- 6.1.1.8 Select the TEST SELECTOR A on the Damper Test Set to the "CSS" position. The SURFACE INDICATOR on the Damper Test Set will probably go off scale and the SERVO CONTROL CURRENT meters on the Auxiliary Test Set will read a high value. Adjust the ELEVATOR AXIS DIFFERENTIAL SERVO control on the Hydraulic Simulator to obtain minimum reading on the SERVO CONTROL CURRENT meters. The SURFACE INDICATOR on the Damper Test Set should now read GOOD.
(This corresponds to sub-para 5.3.6)



- 6.1.1.9 Select the DIRECTION switch on the Damper Test Set from the "+" to the "-" position. This causes the elevators to deflect in the opposite (down) direction and a GOOD reading on the SURFACE INDICATOR located on the Damper Test Set confirms the symmetrical operation of the elevators. Return the DIRECTION switch to the "+" position.
- 6.1.1.10 Select the TEST SELECTOR A on the Damper Test Set to the "n" position. A GOOD reading on the SURFACE INDICATOR, located on the Damper Test Set should be obtained without having to adjust the Hydraulic Simulator more than a small amount (Refer sub-para 5.3.9).
- 6.1.1.11 Select the TEST SELECTOR A on the Damper Test Set to the "q" position. A GOOD reading on the SURFACE INDICATOR, located on the Damper Test Set should be obtained.
- 6.1.1.12 Select on the Damper Test Set the TEST SELECTOR A to the "q h" position and press the HP-INTEG push-switch. When the TEST SELECTOR A is first selected to the "q h" position the SURFACE INDICATOR pointer will deflect off scale but should come back to the GOOD portion of the scale within _____ seconds after the HP-INTEG. push-switch is pressed. A GOOD reading will indicate that the high-pass portion of the pitch rate circuit is operating properly. (Refer sub-para 5.3.11.)
- 6.1.1.13 Select the TEST SELECTOR A on the Damper Test Set to the "PD" position and adjust the ELEVATOR AXIS DIFFERENTIAL SERVO control on the Hydraulic Simulator for minimum current in the SERVO CONTROL CURRENT Meters on the Auxiliary Test Set. The SURFACE INDICATOR on the Damper Test Set should read approximately 5°. Press the PITCH ROLL DISENGAGE push-switch on the Damper Test Set. The SURFACE INDICATOR reading should now decrease to zero as the ELEVATOR AXIS DIFFERENTIAL SERVO control is rotated for minimum current in the SERVO CONTROL CURRENT meters. (Refer to sub-para 5.3.12).
- 6.1.1.14 Select the TEST SELECTOR A on the Damper Test Set to the "SL" position and check that the SURFACE INDICATOR on the Damper Test Set is at "zero" deviation for both left and right elevators as in Steps 6.1.1.6 and 6.1.1.7. This checks for spurious signals in the bridge before checking the operation of the pitch axis integrator. (Refer to sub-para 5.3.13).



- 6.1.1.15 Select on the Damper Test Set the TEST SELECTOR A to the "INTEG". position as in sub-para 5.3.14 and press the HP-INTEG push-switch. A "no-go" indication will be obtained on the SURFACE INDICATOR. Adjust the PITCH AXIS DIFFERENTIAL SERVO control on the Hydraulic Simulator for minimum readings on the SERVO CONTROL CURRENT meters on the Auxiliary Test Set. The SURFACE INDICATOR should now read GOOD.
- 6.1.1.16 Repeat the Tests outlined in sub-para 5.3.15 to 5.3.24 inclusive of this report, obtaining the correct surface position by adjusting the appropriate PITCH AXIS DIFFERENTIAL SERVO controls.
- 6.1.1.17 Select the TEST SELECTOR B on the Damper Test Set to the PITCH GEAR DOWN position and "engage" the Damper by pressing the DAMPER ENGAGE push-switch on the Damper Test Set. Connect test leads from J1 and J2 on the Auxiliary Test Set to test points J_____ and J_____ on the Damper Amplifier Calibrator. Select on the Auxiliary Test Set the VTVM INPUT selector to the EXTERNAL position and the VTVM RANGE switch to the _____ volt range. Operation of the differential servo fader will be indicated by the VTVM deflection reducing to zero. Select the TEST SELECTOR B to the EMERGENCY RUDDER position and then return it to the PITCH GEAR DOWN position. This disengages the servo putting the Damper in the emergency mode. Remove the test leads from J_____ and J_____ on the Damper Amplifier Calibrator and connect them to J_____ and J_____ of the same unit. Select the VTVM RANGE switch to the _____ volts position. Press the DAMPER ENGAGE push-switch on the Damper Test Set. The VTVM needle will again go from zero to approximately _____ volts, indicating that the fader in the pitch axis parallel servo circuit is operating satisfactory. (Refer to sub-para 5.3.27 of this report)
- 6.1.1.18 Select the TEST SELECTOR B on the Damper Test Set to the ROLL GEAR DOWN position and adjust the ROLL AXIS DIFFERENTIAL and PARALLEL SERVO controls on the Hydraulic Simulator for minimum current reading on the SERVO CONTROL CURRENT meters on the Auxiliary Test Set. (It will be necessary to select the SERVO SELECT switch on the Hydraulic Simulator from the ROLL AXIS PARALLEL position to the ROLL AXIS DIFFERENTIAL position to ensure that all servo valve currents are at a minimum). A GOOD indication should be obtained on the SURFACE INDICATOR on the Damper Test Set, indicating correct operation of both differential and parallel servos. (Refer to sub-para 5.3.28)



SECRET

70/MAINT 13/1

- 6.1.1.19 Select the TEST SELECTOR B on the Damper Test Set to the "q c NOR" position and apply a differential pressure of _____ pounds to the Pitot-Static System by means of the MB-1 Pitot-Static Test Set. Adjust the RUDDER AXIS DIFFERENTIAL SERVO control on the Hydraulic Simulator for minimum reading on the SERVO CONTROL CURRENT meters on the Auxiliary Test Set. A GOOD indication should be obtained on the SURFACE INDICATOR on the Damper Test Set indicating correct operation of the "q c" scheduler system as described in sub-paras 5.3.29 and 5.3.30.
- 6.1.1.20 Select the TEST SELECTOR B on the Damper Test Set to the "ALT" position and apply a pressure corresponding to _____ feet of altitude and a differential pressure of _____ pounds to the Pitot-Static System. Adjust the PITCH AXIS PARALLEL SERVO control on the Hydraulic Simulator for a minimum reading on the SERVO CONTROL CURRENT meters on the Auxiliary Test Set. A GOOD indication on the SURFACE INDICATOR on the Damper Test Set will signify correct operation of the altitude scheduler transducer, as the "q c" scheduler has been previously tested. (Refer to sub-para 5.3.32)
- 6.1.1.21 Qualitative operation of the sensors should be checked in a manner identical to that for the sensors on the aircraft, that is, null voltages will be measured by means of the VTVM which is part of the Auxiliary Test Set and the procedures outlined in sub-paras 5.3.33 to 5.3.36 inclusive should be followed.
- 6.1.1.22 Control surface deflections can be measured in a manner similar to that described in sub-para 5.3.38 but it will be necessary, to adjust the appropriate HYDRAULIC SERVO SIMULATOR controls for null voltage on the SERVO CONTROL CURRENT meters, in order to simulate control surface motion before reading the surface deflection on the SURFACE INDICATOR on the Damper Test Set. A faulty operation on any of the above tests should correspond to the faulty operation obtained on the aircraft, for example, if the Damper Amplifier Calibrator is the suspected component a "no-go" indication should be obtained for the same switch positions on the Damper Test Set as was obtained on the aircraft, thus confirming the location of the fault.

6.2 UG 6002A-1 Rate Table (Reference Figure 15)

- 6.2.1 Place the mounting beam on top of the turn table and fasten it down with the bolts provided. Attach the proper mounting brackets to the ends of the mounting beam. Reference should be made to Table 3 for the mounting positions of the accelerometers, the turning rates required and the readings that should be obtained.

TABLE 3

Accelerometer	Bracket and Location	Speed of Rate Table	Balance Reading	VTVM Reading

- 6.2.2 Mount two similar accelerometers at opposite ends of the beam on the appropriate brackets. Connect the cables, select the MODE SELECT switch to the BALANCE position and start the Rate Table. Select the GYRO/ACCELEROMETER switch to the ACCELEROMETER position. Gradually increase the speed of the Rate Table to the value shown in Table 3. Press the METER SENSITIVITY switch down to increase the sensitivity of the meter. The meter deflection should not vary more than \pm _____ volts throughout the range of operation. This test assures the linearity of the accelerometers and is a check for sticking wipers and a test of the maximum turning rate. Should the operation of the accelerometers be within tolerance they may be removed from the Rate Table and installed in the aircraft. This test may be repeated for all the accelerometers using the appropriate mounting brackets and mounting positions.
- 6.2.3 Should the reading between the two accelerometers exceed the allowable limits it is obvious that one of the units is faulty. In this case select the MODE SELECT switch to LEFT ACCELEROMETER position and repeat the test through the range where the faulty operation was discovered, measuring the output of the accelerometer with the VTVM at the discreet speeds indicated in Table 3. Readings corresponding to those listed on Table 3 should be obtained. If this is the case repeat the tests with the MODE SELECT switch selected to the RIGHT ACCELEROMETER position. Faulty readings should be obtained indicating that this accelerometer is non-serviceable.



- 6.2.4 Those accelerometers that have heater units will be tested by pressing the HEATER TEST push-switch and observing if the HEATER TEST lamp illuminates. Should the lamp not illuminate it will be necessary to press the lamp itself to assure that it is not burned out. Pressing the lamp completes a circuit causing the lamp to illuminate if it is serviceable.
- 6.2.5 Accelerometers that perform switching functions are tested by rotating them at a speed such that the acceleration applied is just below that required to operate the switch. The indicator lamp on the control console will not be illuminated. The speed of the turntable is then increased to a value just above that required to activate the switch and the lamp should illuminate, indicating closure of the switch in the accelerometer.
- 6.2.6 Remove the mounting beam and brackets from the turntable and store them in their position behind the control console. Place the gyro mount at the centre of the turntable using the mounting holes provided, and attach the gyro package with the base of the package parallel to the surface of the turntable. This will permit the yaw rate gyros to be tested. Set the speed of the turntable to the discreet values given in Table 4 and observe that the VTVM readings are within the limits shown in Table 4.

TABLE 4

GYRO	POSITION	SPEED	VTVM READING

- 6.2.7 Repeat the tests for the pitch rate and roll rate gyros by placing the gyro package on the mount so that the appropriate axis is activated, and setting the table speeds to the values given to Table 4, checking that the VTVM readings are again within tolerance. These tests will indicate satisfactory operation in so far as linearity, maximum turning rates and sensitivity of the various gyro units are concerned. Should a faulty operation be recorded it will be necessary to replace the faulty gyro, re-checking the calibration of the package to make sure that the alignment of the unit is correct.
- 6.2.8 If the Rate Table is connected to the Damper Test Stand by means of the cables provided and the TEST STAND RATE TABLE switch placed in the RATE TABLE position, it will be possible to feed signals directly from the sensor on the Rate Table into the Damper bridge.



6.2.8 (continued)

It will be necessary to use the Hydraulic Simulator on the Test Stand in the manner described previously in this report in order to set up the proper simulated control surface position.

6.2.9 The proper operation of the "G" Limiter System may be tested by placing the "G" Limit accelerometers on the mounting beam on the Rate Table and applying their output to the "G" Limiter Amplifier Calibrator mounted on the Test Stand. Set the "G" Limiter Accelerometers on the beam in the positions shown in Table 3 and gradually increase the speed of rotation of the Rate Table through the range shown. (The Damper should be in the ENGAGED mode). Below a value of _____ rpm the Damper should remain engaged, but, for a speed greater than _____ rpm proper operation of the "G" Limiter system will be indicated by the DISENGAGE LAMP illuminating indicating that the Damper system is disengaged.

6.2.10 Should the Damper fail to disengage it will be necessary to check the operation of the "G" Limiter by means of the UG 6006A-1 "G" Limiter Test Set. If the Damper system disengages, faulty operation of the "G" Limiter accelerometers may be checked in the manner described in Table 3. Should the Damper refuse to disengage it is probable that the "G" Limiter Amplifier Calibrator is out of calibration. This will be indicated by the UG 6006A-1 "G" Limiter Test Set and the appropriate calibration steps can be taken.



SECRET

70/MAINT 13/1

APPENDIX I

NO. 1

DESCRIPTION	AVRO PART NO.	MANUFACTURER'S		FUNCTION
		NAME	PART NO.	
Amplifier Calibrator	7-1362-232	M.H.	D-BG92A-1	Computes and schedules Damper signals
Function Selector Panel	7-1352-117	M.H.	D-CG77A-1	Pilot's Damper control panel
Calibrator-"G" Limiter	7-1354-233	M.H.	D-BG67E-1	Computes "G" Limiting signals
Accelerometer - Lateral Scheduling	7-1352-118	M.H.	D-GG47D-1	Schedules roll rate command with lateral acceleration
Accelerometer - Normal Switching	7-1364-236	M.H.	D-GG62B-1	Cuts auto-trim above $\pm 0.5G$ on AFCS
Accelerometer - Normal "G" Limiter (FWD)	7-1354-234	M.H.	D-GG47E-2	Supplies normal acceleration and pitch acceleration signals to the "G" limiter.
Accelerometer - Normal "G" Limiter (AFT)	7-1354-234	M.H.	D-GG47E-2	Supplies normal acceleration and pitch acceleration signals to the "G" limiter.
Accelerometer - Normal	7-1354-231	M.H.	D-GG58A-1	Supplies normal acceleration signal to amplifier calibrator
Accelerometer (Lateral EMERG)	7-1354-232	M.H.	D-GG58B-1	Supplies lateral acceleration signal to amplifier calibrator
Feel and Trim Unit-Aileron	7-1552-341	AiResearch	39872-2	Provides mean for aileron artificial feel and trim
Feel and Trim Unit - Elevator	7-1562-247	AiResearch	39872-1	Provides mean for elevator artificial feel and trim

DAMPER AND ASSOCIATED EQUIPMENT LIST



APPENDIX I

DESCRIPTION	AVRO PART NO.	MANUFACTURER'S		FUNCTION
		NAME	PART NO.	
Accelerometer - Lateral Switching	7-1351-33	M.H.	D-GG62C-2	Disengages normal yaw damper and engages emergency damper if yaw damper parameter limits are exceeded.
Accelerometer - Lateral Normal	7-1354-232	M.H.	D-GG58B-1	Supplies lateral acceleration signal to amplifier calibrator
Accelerometer - Roll Rate Limiting	7-1364-64	M.H.	D-GG59A-1	Disengages roll axis if max. roll rate is exceeded.
Accelerometer - Lateral Switching	7-1354-229	M.H.	D-GG62C-1	Disengages normal yaw Damper and engages emergency damper if Yaw damper parameter limits are exceeded.
Feel and Trim Emergency Release Unit - Elevator	7-1562-713	AiResearch	525328	Release trimming during emergency operation
Indicator - Side Slip	7-1252-258	Buffalo Instr. Co.	25101-A30E-1-B1	Indicate side slip angle.
Sensor - Relative Wind & Air Pressure	7-1851-21	Buffalo Instru. Company		Provide side slip and angle of attack signal to Damper system and Indicator
Indicator - Control Surface Response	7-1252-136	Daystrom Ltd.	1889 Type 8	Indicate control surface response
Transducer - Stick Force	7-1552-383	Humphrey	FT01-0101-1	Provide electrical command signal to AMP. CAL to Stick force
Magnetic Amplifier	7-1583-165	Garrett	47648	Amplifiers signal from "q" transducer for "q" actuator

DAMPER AND ASSOCIATED EQUIPMENT SET



APPENDIX I

NO. 3

DESCRIPTION	AVRO PART NO.	MANUFACTURER'S		FUNCTION
		NAME	PART NO.	
GYRO-Yaw Rate (Normal)	7-1362-231	M.H.	D-GG72A-1	Supplies angular displacement rate signals to AMP-CAL
GYRO - Yaw Rate (Emerg)	7-1362-231	M.H.	D-GG72A-1	Supplies angular displacement rate signals to AMP-CAL
GYRO - Pitch Rate	7-1362-234	M.H.	D-GG72A-3	Supplies angular displacement rate signals to AMP-CAL
GYRO - Roll Rate	7-1362-235	M.H.	D-GG72A-2	Supplies angular displacement rate signals to AMP-CAL
Parallel Servo - Aileron	7-3262-167	M.H.	MG-55M-2	Provides command signal to aileron control valve
Parallel Servo - Elevator	7-3262-165	M.H.	MG-55N-2	Provides command signal to elevator control valve
Differential Servo - Left Aileron	7-3260-11	M.H.	MG-51D-1	Provides damping motion signal to left aileron control valve.
Differential Servo - Right Aileron	7-3260-11	M.H.	MG-51D-1	Provides damping motion signal to right aileron control valve.
Differential Servo - Left Elevator	7-3260-11	M.H.	MG-51D-1	Provides damping motion signal to left elevator control valve.
Differential Servo - Right Elevator	7-3260-11	M.H.	MG-51D-1	Provides damping motion signal to right elevator control valve
Dual Differential Servo-Rudder	7-3283-7	M.H.	D-MG62B-1	Provides damping and turn co-ordination signals to rudder control valve.
Damper Circuit Breaker Panel	7-1282-259	Avro Aircraft		Provides wiring and equipment protection.

DAMPER AND ASSOCIATED EQUIPMENT LIST



APPENDIX I

NO.4

DESCRIPTION	AVRO PART NO.	MANUFACTURER'S		FUNCTION
		NAME	PART NO.	
Potentiometer - Left Elevator Differential Servo position	7-1162-173	Garrett		Provides signals to Damper "G" Limiter
Potentiometer - Right Elevator Differential Servo Position	7-1162-173	Garrett		Provides signals to Damper "G" Limiter
Potentiometer - Left Aileron Position	7-1164-11	Helipot Corp.	RPI7-0101-1	Provides L. Aileron position to indicator. Provides L. Aileron position for ground Tests
Potentiometer - Right Aileron Position	7-1164-11	Helipot Corp.	RPI7-0101-1	Provides R. aileron position to indicator. Provides R. aileron position for ground Test.
Potentiometer - Rudder Position	7-1100-21	Helipot Corp.	SX-1274	Provides rudder position to indicator. Provides rudder position for ground test
Potentiometer - Left Elevator Position	7-1100-21	Helipot Corp.	SX-1274	Provides L. Elevator position signal to indicator
Potentiometer - Right Elevator Position	7-1100-21	Helipot Corp.	SX-1274	Provides R. elevator position signal to indicator
Differential Transformer - Left Aileron Position	7-1100-23	GL Collins	LMT-1241X	Provides L Aileron position signal to Damper during normal and emergency damper operation
Differential Transformer - Right Aileron Position	7-1100-23	G.L. Collins	LMT-1241X	Provides R. Aileron position signal to Damper during normal and emergency damper operation

DAMPING AND ASSOCIATED EQUIPMENT LIST



APPENDIX I

NO. 5

DESCRIPTION	AVRO PART NO.	MANUFACTURER'S		FUNCTION
		NAME	PART NO.	
Linear "q" Actuator - Rudder	7-1583-61	AiResearch	2985-2	Provides displacement signal proportional to "q" to rudder feel unit.
Trim Actuator - Rudder	7-1583-63	AiResearch	39886	Provides trimming to rudder
Potentiometer - Elevator Parallel Servo Position	7-1358-13	M.H.	D-LG-16K-1	Supplies stick position signal to "G" Limiter

DAMPING AND ASSOCIATED EQUIPMENT LIST

Working Paper for the Registrar

No.	Description	Date	Amount	Particulars
1	To Balance b/d	1-1-1912	1000	By Balance b/d
2	To Cash	1-1-1912	1000	By Cash
3	To Cash	1-1-1912	1000	By Cash
4	To Cash	1-1-1912	1000	By Cash
5	To Cash	1-1-1912	1000	By Cash
6	To Cash	1-1-1912	1000	By Cash
7	To Cash	1-1-1912	1000	By Cash

1000



REGISTRAR

REGISTRAR GENERAL