

CEPE Mylands

4c Armstrong

CONFIDENTIAL  
**UNCLASSIFIED**

Classification cancelled / Changed to UNCLASS  
By authority of AVES  
Date 27 Sept 56  
Signature [Signature]  
Unit / Rank / Appointment AVES

ANALYZED

**FILE IN VAULT**

# ARROW 1 SERVICE DATA

## SECTION 38

### ELECTRICAL SYSTEM

### MASTER WARNING

(This data supersedes previous issue dated 15 Jan 58)

NRC - CISTI  
J. H. PARKIN  
BRANCH

MAY 24 1956

ANNEXE  
J. H. PARKIN  
CNRC - ICIST

15 JUN 58

CONFIDENTIAL

UNCLASSIFIED

# ARROW 1 SERVICE DATA

## LIST OF REVISIONS

DATE

PAGE NO.

DATE

PAGE NO.

# ARROW 1 SERVICE DATA

## MASTER WARNING SYSTEM

### TABLE OF CONTENTS

TITLE	PAGE
SYSTEM SERVICE DATA	
DESCRIPTION	
General . . . . .	1
Indicator Light Panel . . . . .	1
Master Control Unit . . . . .	4
Bail-Out Indicator Circuit . . . . .	6
INSPECTION (To be issued later)	
FUNCTION TESTING	
System Function Test . . . . .	7
COMPONENT SERVICE DATA	
Indicator Light Panel - E15 . . . . .	11
Control Unit - E140 . . . . .	13

### LIST OF ILLUSTRATIONS

FIGURE	TITLE	PAGE
1	Indicator Light Panel . . . . .	2
2	Master Warning System Schematic . . . . .	5
3	Master Light Control and Reset Circuit Schematic . . . . .	6
ROUTING DIAGRAMS		
4	Master Warning System . . . . .	8
5	Bail-Out Indicator Circuit . . . . .	9

## ARROW 1 SERVICE DATA

## DESCRIPTION

## GENERAL

1 Warning of malfunction of certain systems is given by the illumination of either a red or an amber master warning light fitted on the main instrument panel. The specific system or component affected by malfunction is identified by the illumination of an indicator light, one such light being provided for each system or component. The indicator lights, with the exception of the fire warning and the air conditioning engine bleed indicator lights, are located on a panel fitted in the RH console. The fire warning indicator lights are located on the LH console, and the air conditioning engine bleed indicator lights are located on the RH console.

2 The circuits to the master warning lights and the indicator lights are completed through a control unit.

## INDICATOR LIGHT PANEL (Fig 1)

3 Twenty-six indicator lights, a PRESS-TO-RESET switch, a DAY-NIGHT switch and a PRESS-TO-TEST switch are located on the indicator light panel.

4 The PRESS-TO-RESET switch is used to switch off the master light after the illumination of an indicator light. The indicator light remains operative until the system fault is cleared.

5 The DAY-NIGHT switch, when selected to NIGHT, introduces a resistor into the return circuit of the indicator lights to reduce the brilliance of illumination. An exception to this is the fire warning lights which are not dimmed.

6 The PRESS-TO-TEST switch operates the master test circuit which facilitates checking the filaments of all the indicator lights associated with the warning system. These are as follows:

- (a) Master warning lights.
- (b) Indicator lights located on the indicator panel.

(c) Fire warning indicator lights.

(d) Warning circuits indicator light fitted in the knob of the landing gear selector lever.

(e) Pilot's indicator light of the bail-out indicator circuit.

7 With the exception of the master test circuit, the master warning system derives its supply from the emergency DC bus-bar via the MASTER WARNING circuit breaker on panel E1. The master test circuit derives its supply from the main DC bus-bar via the MASTER TEST circuit breaker on panel E1.

8 An identification plate, upon which is inscribed the system or function served, is provided for each indicator. The inscription on the plate is translucent white against a black background. If an indicator is handed, this is indicated by the letter L or R and an arrow pointing in the appropriate direction. At present, one indicator is not used; the function of the remaining 25 indicators and the master warning given are as follows:

(a) FUEL LOW, L and R. If the fuel in the LH or the RH fuel collector tank falls below 65% capacity (approximately 720 lbs), the appropriate L or R FUEL LOW indicator light and the amber coloured master light will illuminate. Note that, when this condition exists, the FUEL PROP indicator light will also illuminate.

(b) FUEL PROP. The FUEL PROP indicator light and the amber coloured master light will illuminate if any of the following four conditions exist:

(1) The level of the fuel in the LH or the RH fuel collector tank falls below 65% capacity (approximately 720 lbs).

(2) The LH or the RH fuel transfer pump has failed. When this condition exists, the circuit to the indicator light is completed by differential pressure switches fitted in the LH and the RH fuel transfer lines.

(3) Either or both refuelling adaptor doors are open.

ARROW 1 SERVICE DATA

(4) The master refuelling switch is selected on.

(c) ENG EMER FUEL ON. This indicator light illuminates when the LH or the RH ENGINE FUEL switch is set to EMERG and the selector valve in the appropriate engine fuel control unit is in the emergency position. A master indication is not given when this circuit is operative.

(d) FUEL PRESS L and R. If the fuel delivery pressure to the LH or the RH engine

drops below 15.9 - 16.9 psia, the appropriate L or R FUEL PRESS indicator light and the amber coloured master light illuminate. On pressure rising, the indicator light is extinguished when the pressure exceeds 18.3 psia.

(e) OIL PRESS, L and R. The appropriate L or R OIL PRESS indicator light and the amber coloured master light will illuminate if the differential oil pressure between the LH or the RH engine oil pump and oil sump is less than 25 psi.

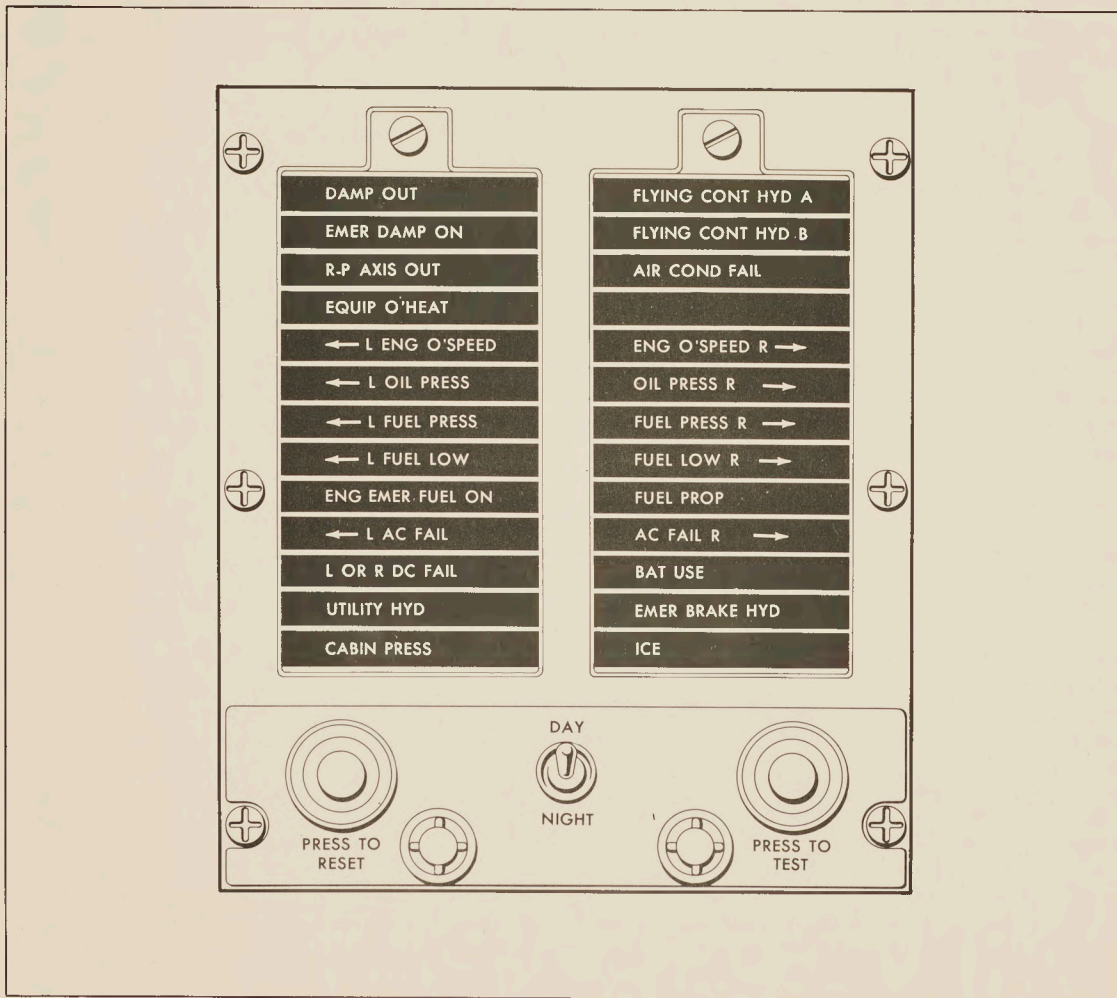

7M1-6010-1

FIG. 1 INDICATOR LIGHT PANEL

## ARROW 1 SERVICE DATA

- (f) FLYING CONT HYD A and B. If the pressure in either system A or system B of the flying control hydraulics is less than 600 - 1400 psi, the appropriate FLYING CONT HYD A or B indicator light and the amber coloured master light illuminate. If the pressure in both systems is less than 600 - 1400 psi the red coloured and the amber coloured master lights illuminate. The indicator lights are extinguished when the pressure increases to 2800 - 3600 psi.
- (g) UTILITY HYD. If the utility hydraulic system pressure is less than 600 - 1400 psi, the UTILITY HYD indicator light and the amber coloured master light illuminate. The indicator light is extinguished when the pressure increases to 2800 - 3600 psi.
- (h) EMER BRAKE HYD. If the emergency brake hydraulic system pressure is less than 1400 - 1800 psi, the EMER BRAKE HYD indicator light and the amber coloured master light illuminate. The indicator light is extinguished when the pressure increases to 2600 - 3400 psi.
- (j) AC FAIL, L and R. If a phase failure occurs in the LH or the RH AC system, the appropriate L or R AC FAIL indicator light and the amber coloured master light illuminate. Illumination of the L or the R AC FAIL indicator light is accompanied by the illumination of the indicator light for L or R DC FAIL. The illumination of an AC FAIL indicator light provides an indication that the total possible AC and DC load demand has been reduced to a value compatible with the capacity of one supply source.
- (k) L or R DC FAIL. If the LH or the RH transformer-rectifier unit DC output fails, the L or R DC FAIL indicator light and the amber coloured master light illuminate. The illumination of the L or R DC FAIL indicator light provides an indication that the total possible DC load demand has been reduced to a value compatible with the capacity of one supply source.
- (m) BAT USE. This indicator light and the amber coloured master light illuminate when DC power is being supplied by the battery.
- (n) ENG O'SPEED L and R. If the LH or the RH engine low pressure compressor rotor speed increases to between 7260 and 7330 rpm, the appropriate L or R ENG O'SPEED indicator light and the amber coloured master light illuminate.
- (p) CABIN PRESS. This indicator light and the amber coloured master light illuminate if the cabin pressure is equivalent to a pressure altitude of 31,000 feet.
- (q) AIR COND FAIL. This indicator light and the amber coloured master indicator light illuminate when the air conditioning cooling turbine outlet temperature exceeds 80°F. The indicator light is extinguished when the temperature drops to 60°F.
- (r) EQUIP O'HEAT. This indicator light and the amber coloured master light illuminate when the equipment air supply temperature increases to 95 - 105°F. The indicator light is extinguished when the temperature decreases to 55 - 65°F.
- (s) ICE. This indicator light and the amber coloured master light illuminate when icing conditions in the engine air intakes are detected. Note that the operation of the indicator light is cycled by the action of the ice detector, but, by the action of the master warning circuit, the master light will remain illuminated until reset.
- (t) EMER DAMP ON. This indicator light and the amber coloured master light illuminate when the rudder is being operated by the emergency damping. When this condition exists the R-P AXIS OUT indicator light is also illuminated.
- (u) DAMP OUT. This indicator light and the amber coloured master light illuminate when the damper system is inoperative.
- (v) R-P AXIS OUT. This indicator light and the amber coloured master light illuminate when the roll and/or pitch axis damping is out.
- 9 The master control unit effects the illumination of the red coloured master light if a fire warning light circuit is operative.
- 10 The appropriate LH or RH ENG BLEED indicator light illuminates if the air pressure

## ARROW 1 SERVICE DATA

in the LH or the RH air conditioning engine bleed duct exceeds 120 psi, or due to leakage, the temperature within the ducting insulation increases to 350 - 400°F.

## MASTER CONTROL UNIT (Fig 2)

11 The function of the master control unit is to complete a supply circuit to the appropriate master light and indicator light on receipt of a signal from the system or component affected by malfunction. Circuits are included in the unit to facilitate testing the filaments of the warning system indicator lights and reduce the brilliance of illumination of certain of these lights. The appropriate master light is extinguished and its circuits reset to receive further warning signals by a circuit incorporated in the unit.

12 Two master light control circuits are included in the control unit and serve to complete a supply circuit to the red or the amber coloured master light, as appropriate, when a malfunction occurs in a system or component. Each master light control circuit consists of two transistors, a resistance network and a circuit relay. The master light control circuits are operated by a signal input circuit comprising a capacitor and crystal diode. The action of the capacitor is used to trigger the operation of the master light control circuits. The function of the diode is to prevent feedback to the signal input circuits when a master circuit is operative. Each of the warning circuits requiring master indication incorporates a signal input circuit. See fig 3.

13 A master light control circuit is basically an electronic switch which controls the operation of the circuit relay. The relay, when energized, completes the master light supply circuit. The operation of a master light control circuit is described briefly in the following paragraphs.

14 In normal operation, i.e. under 'standby' conditions, the voltage dividing resistors R1 and R2 in combination with resistor R6 establish a potential difference between the base (B1) and emitter (E1) of the first stage transistor TR1. The potential difference is such that the base is negative with respect to the emitter and the transistor conducts. When transistor TR1 conducts, current flow through resistors R3

and R6 cause the voltage appearing at the collector (C1) to increase and the voltage appearing at the emitter (E1) to decrease. These voltage changes, which are applied to the base (B2) and emitter (E2) of the second stage transistor TR2 through resistor R4 and the common line, bias transistor TR2 to cut-off.

15 When a positive warning signal is applied to a signal input capacitor (C1), a pulse voltage caused by the capacitor charging current is developed across the input capacitor (C1). This action drives the base (B1) of transistor TR1 highly positive thereby biasing the transistor to cut-off. With current flow through transistor TR1 interrupted, the potential difference between the base (B2) and emitter (E2) of the second stage transistor TR2 is such that the transistor conducts. This potential difference is established by voltage dividing resistors R3, R4 and R5 in combination with resistor R6. When transistor TR2 conducts, current flow through resistors R7 and R6 bias transistor TR1 to cut-off. When current flows in the collector (C2) circuit of transistor TR2 the series connected circuit relay is energized. The relay, when energized, completes a supply circuit to the master light. The control circuit is maintained in this operating condition until manually reset.

16 The control circuit is prepared for receipt of further warning signals by depressing the PRESS-TO-RESET switch, located on the master warning panel. This action introduces a resistor into the base circuit of transistor TR1 causing a decrease in voltage at the base (B1) sufficient to permit the transistor to conduct and return the circuit to 'standby' conditions.

17 The master test circuit is operative when the PRESS-TO-TEST switch, located on the master warning panel, is depressed. This action completes a supply to the indicator lights associated with the system. (See para 6). The supply to each light is completed via a crystal diode each of which function to isolate the indicator circuits from each other, so preventing erroneous indications when a signal is supplied by a warning device. An additional diode is fitted in each of the input circuits to prevent feedback to the warning devices when the master test circuit is operative.

ARROW 1 SERVICE DATA

18 The brilliance of illumination of those indicator lights not fitted on the master warning panel is reduced by a circuit included in the unit. An exception to this action is the fire warning lights which cannot be dimmed. The circuit is operative when the DAY-NIGHT switch, located on the master warning panel, is selected to NIGHT. This action completes a supply circuit to energize the dimming control relay. This relay, when energized, introduces a resistor into the supply circuit of the following indicator lights:

- (a) Air conditioning engine bleed indicator lights, LH and RH.
- (b) Pilot's bail-out indicator light.
- (c) Red and amber master lights.

BAIL-OUT INDICATOR CIRCUIT

19 The bail-out indicator circuit provides a visual and an aural bail-out signal in the rear cockpit and also provides an indication in the front cockpit when the rear seat is ejected.

20 The circuit consists of a bail-out switch and a green coloured indicator light in the front cockpit and, in the rear cockpit, a red coloured indicator light and a buzzer unit. The supply for the circuit is derived from the emergency DC bus via the BAIL-OUT circuit breaker located in JB R1 and the normally-open contacts of a micro-switch fitted on the rear cockpit ejection seat rails. The normally-open contacts of the micro-switch are retained in the closed position by the ejector seat. When the bail-out

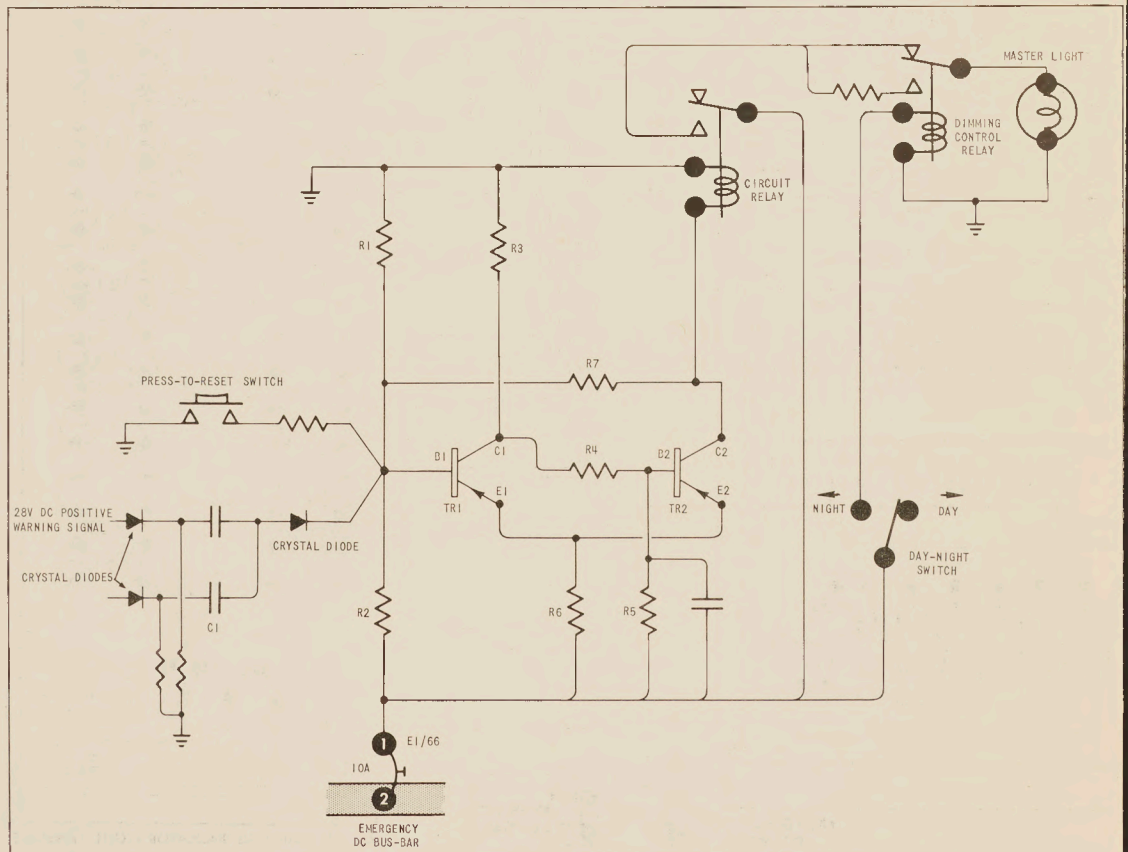

7M1-600B-1

FIG. 3 MASTER LIGHT CONTROL AND RESET CIRCUIT SCHEMATIC

NAVIGATORS BAIL-OUT WARNING INDICATOR LIGHTS

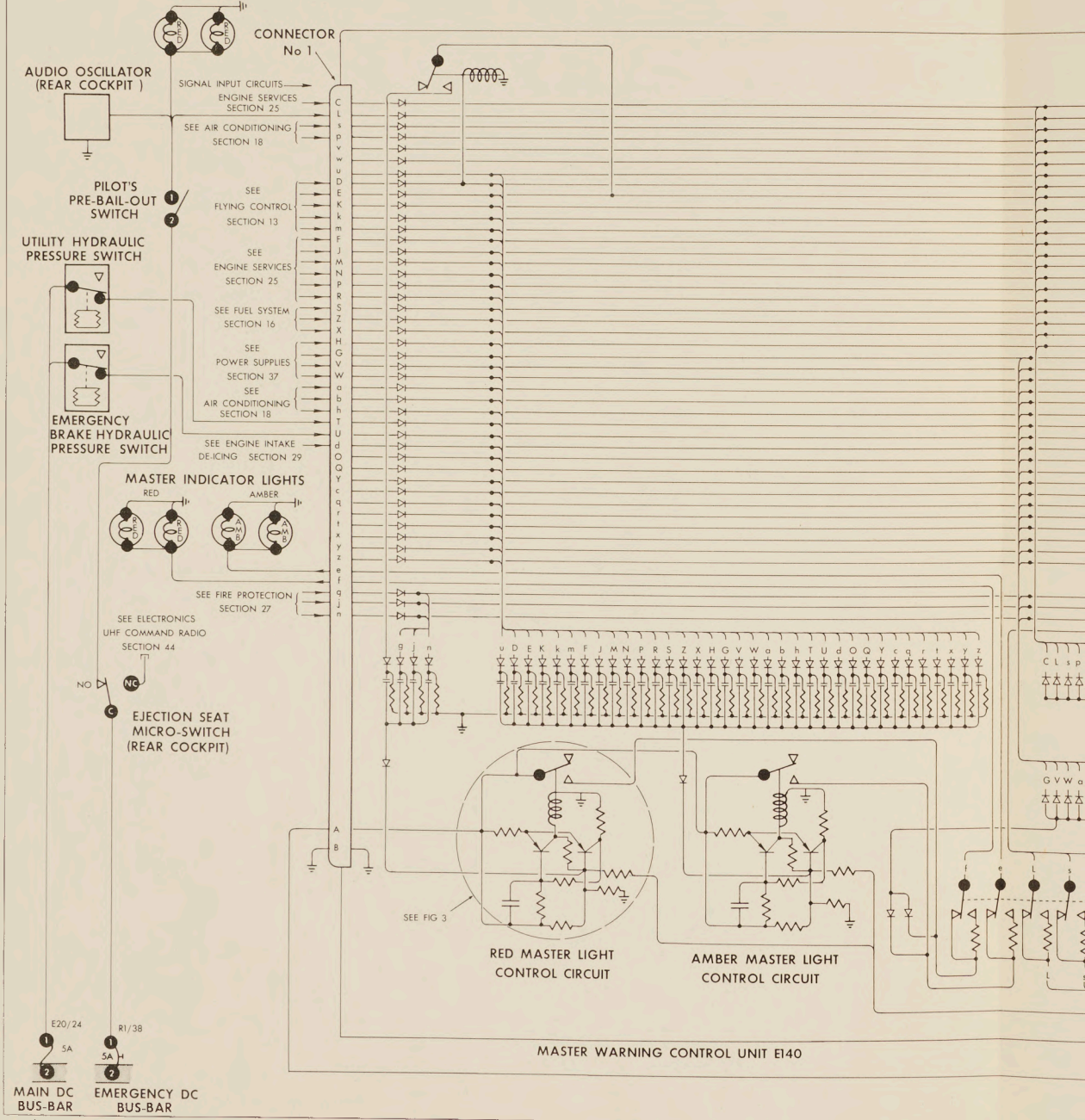

ARROW 1 SERVICE DATA

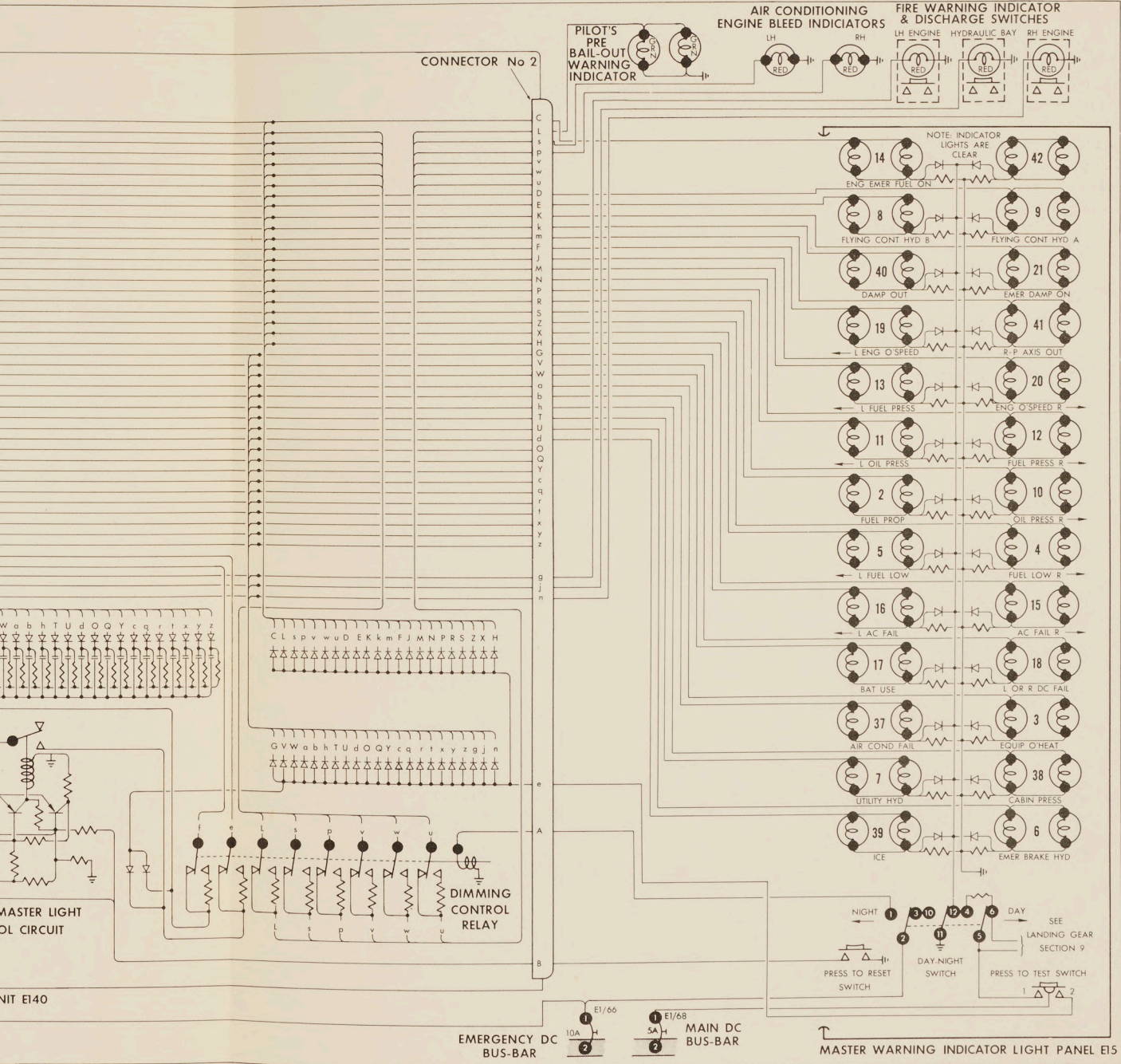

FIG. 2 MASTER WARNING SYSTEM SCHEMATIC

switch is o  
via the m  
cockpit in  
cator and  
cockpit se  
which inte

#### SYSTEM I

21 Che  
associate  
proceedin

(a) En  
connected

(b) De  
and note t  
are illum

(1) T  
lights loc

(2) A  
indicator

(3) T  
indicator

(4) T  
located o

(5) T  
fitted in t  
lever.

(6) T  
fitted on t  
cockpit.

(c) W  
pressed,  
NIGHT po  
warning i  
unchanged  
of illumina  
listed in c

## ARROW 1 SERVICE DATA

switch is closed, a supply circuit is completed via the micro-switch contacts to the front cockpit indicator and to the rear cockpit indicator and buzzer unit. The ejection of the rear cockpit seat permits the micro-switch to open, which interrupts the supply circuit.

## FUNCTION TESTING

## SYSTEM FUNCTION TEST

21 Check the serviceability of the indicators associated with the master warning system proceeding as follows:

(a) Ensure that a source of AC power is connected to the external supply receptacle.

(b) Depress the PRESS-TO-TEST switch and note that the indicator lights listed below are illuminated:

(1) The red and the amber master warning lights located on the main instrument panel.

(2) All indicator lights located on the indicator light panel fitted in the RH console.

(3) The air conditioning engine bleed indicator lights located on the RH console.

(4) The fire warning indicator lights located on the LH console.

(5) The warning circuits indicator light fitted in the knob of the landing gear selector lever.

(6) The bail-out circuit indicator light fitted on the main instrument panel in the front cockpit. See also para 24.

(c) With the PRESS-TO-TEST switch depressed, select the DAY-NIGHT switch to the NIGHT position. With the exception of the fire warning indicator lights which should remain unchanged in brilliance, check that the brilliance of illumination of the remaining indicator lights listed in operation (b) is reduced.

22 Check the operation of the reset circuit for the amber and the red master light proceeding as follows:

(a) Switch off the AC control switches or the external supply. The BAT USE indicator light and the amber master light should illuminate.

NOTE

Do not use the battery longer than necessary.

(b) Depress the PRESS-TO-RESET switch and check that the amber master light is extinguished. Reset the AC control or switch on the external supply.

23 Check the red master light reset circuit proceeding as follows:

(a) Hold the FIRE DETECTION switch, located on the refuelling and test panel E21, to the TEST position. Check that the fire warning lights and the red master light are illuminated.

(b) Depress the PRESS-TO-RESET switch and check that the red master light is extinguished.

24 The bail-out indicator and buzzer unit in the rear cockpit can be checked by raising the guard and operating the NAV BAIL-OUT switch located on the LH console in the front cockpit. When the switch is operated, the BAIL-OUT indicator light and buzzer unit in the rear cockpit should be operative. Note that when the switch is operated the NAV BAIL-OUT indicator light on the main instrument panel in the front cockpit will illuminate.

25 The functioning of the operating circuits of indicator lights is covered during function testing of their relevant systems.

ARROW 1 SERVICE DATA

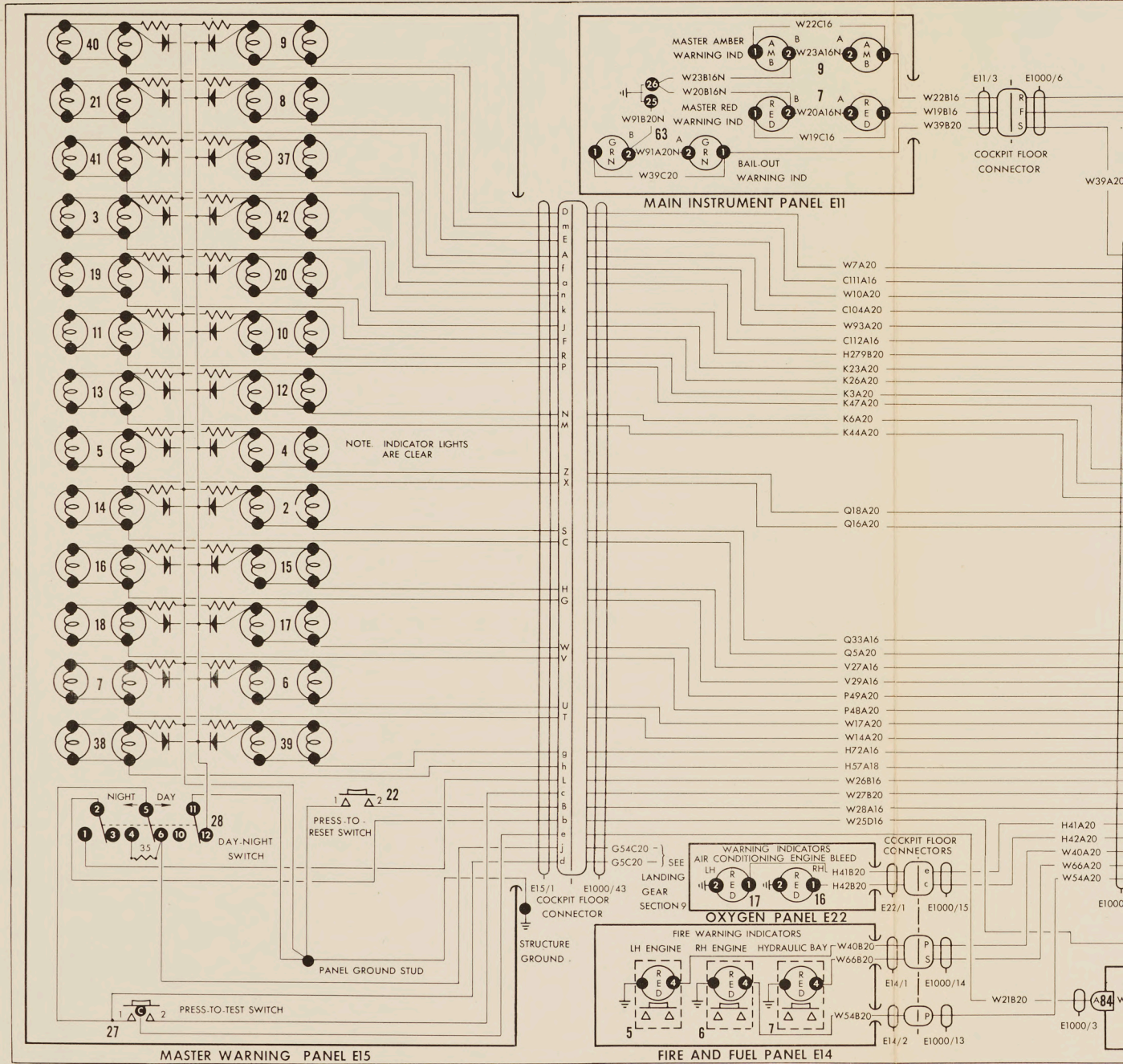
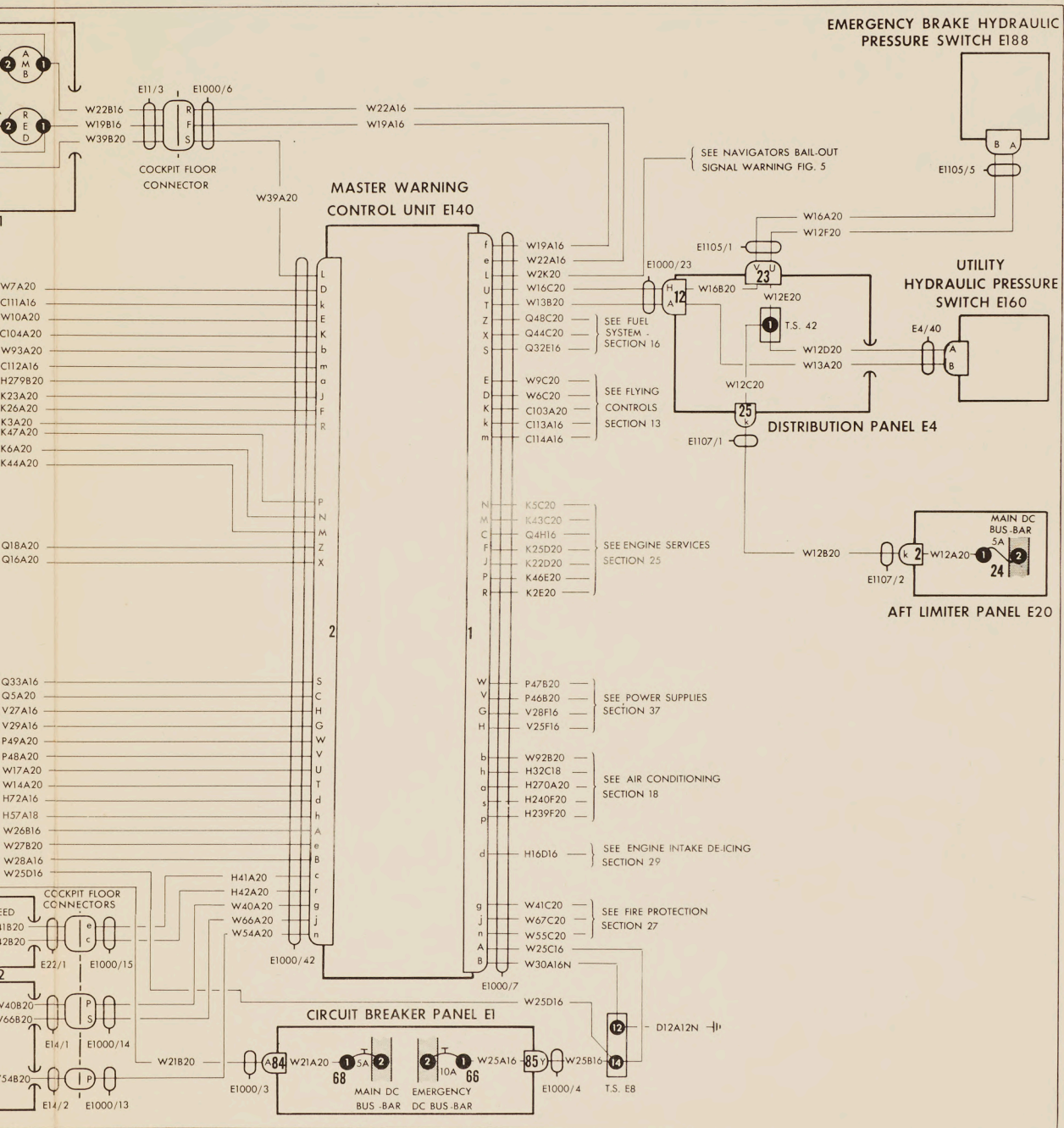

FIG. 4 MASTER WARNING SYSTEM



CONFIDENTIAL  
**UNCLASSIFIED**

## ARROW 1 SERVICE DATA COMPONENT DATA SHEET

SYSTEM ELECTRICAL	SUB-SYSTEM MASTER WARNING	COMPONENT Indicator Light Panel - E15	REF. NO.
AVRO PART NO. 7-1252-344	MANUFACTURER Grimes Manufacturing Company	MAN'FR'S PART NO. 41255	AIRCRAFT EFFECTIVITY 25201
OVERHAUL LIFE: KNOWN-		ESTIMATED- 500 hours	
<p>FUNCTION</p> <p style="margin-left: 100px;">Houses: Warning Indicator Lights          Night and Day Switch )          Press-to-test Switch )      For warning lights.          Press-to-reset Switch )</p>			
<p>LOCATION</p> <p style="margin-left: 100px;">Front cockpit - RH console, forward.</p>			
<p>ACCESS</p> <p style="margin-left: 100px;">Incorporated in the RH console as a detachable panel.</p>			MEN X MINUTES
<p>REPLACEMENT PROCEDURE</p> <p style="margin-left: 100px;">Connect one connector. Secure six quick fasteners.</p>			MEN X MINUTES

CONFIDENTIAL  
**UNCLASSIFIED**

### ARROW 1 SERVICE DATA

INSPECTION  Release inner panels and check contacts for security and damage. Check switches for security.	MEN X MINUTES	
FUNCTIONAL CHECKS	MEN X MINUTES	
GROUND HANDLING AND GROUND TEST EQUIPMENT		
SPECIAL TOOLS TO REMOVE OR SERVICE		
REMARKS		

**UNCLASSIFIED** CONFIDENTIAL

ARROW 1 SERVICE DATA  
COMPONENT DATA SHEET

SYSTEM ELECTRICAL		SUB-SYSTEM MASTER WARNING		COMPONENT Control Unit - E140		REF. NO.	
AVRO PART NO. 7-1152-15043		MANUFACTURER Grimes Manufacturing Company		MAN'FR'S PART NO. 40935		AIRCRAFT EFFECTIVITY 25201	
OVERHAUL LIFE:		KNOWN-		ESTIMATED-		500 hours	
FUNCTION  Incorporates circuits which operate master warning lights in cockpit.							
LOCATION  Nosewheel Bay. LH side. Station 166.66 - 176.00.							
ACCESS  Nosewheel well, unobstructed.						MEN X MINUTES	
REPLACEMENT PROCEDURE  Fit four AN520-10-R screws. Connect two connectors.						MEN X MINUTES	

ARROW 1 SERVICE DATA

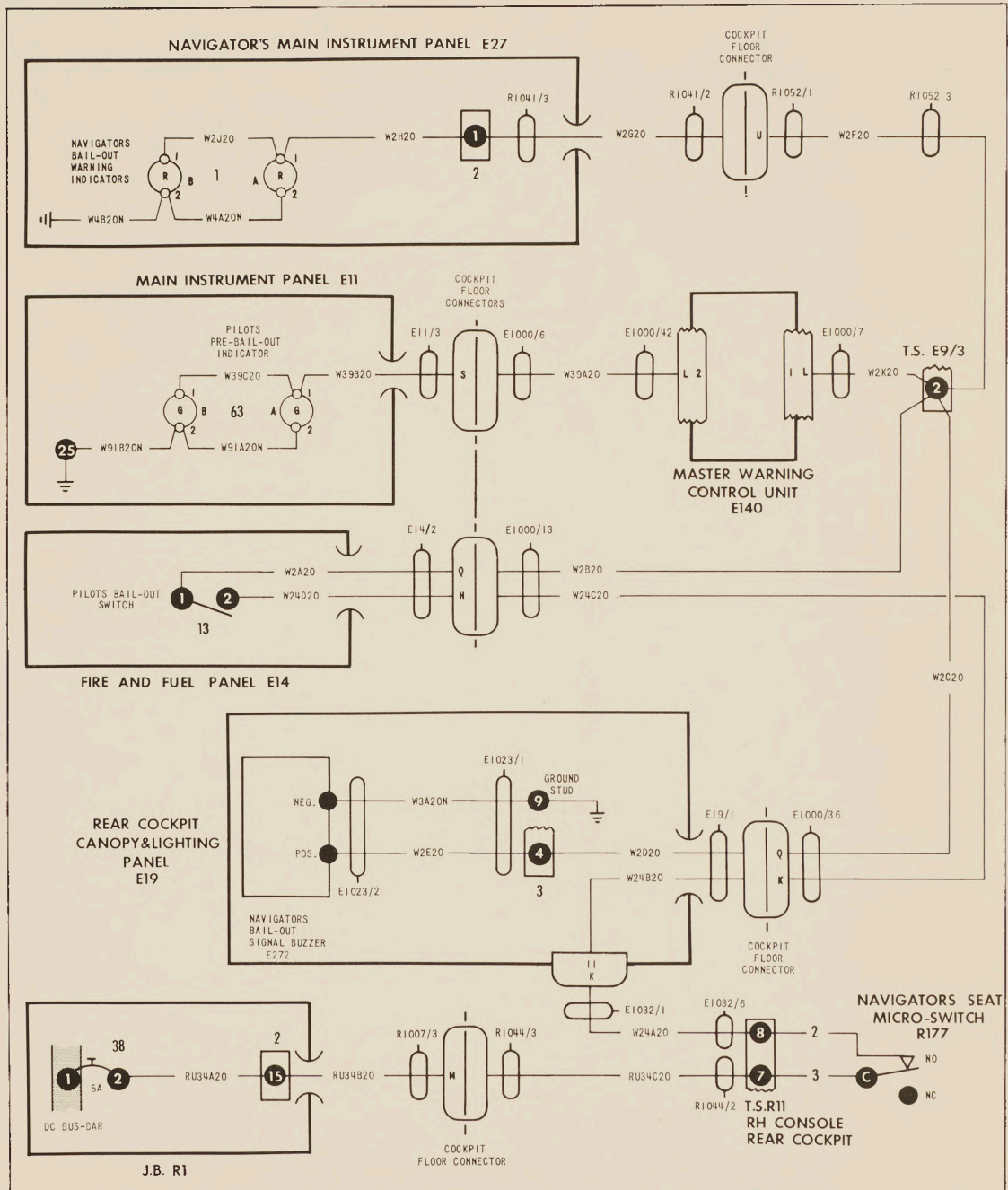

7M1-6004-2

FIG. 5 BAIL-OUT INDICATOR CIRCUIT

CONFIDENTIAL

### ARROW 1 SERVICE DATA

<p>INSPECTION</p>  <p>Check security of mounting. Check that connectors are secure and properly fitted.</p>	MEN X MINUTES	
<p>FUNCTIONAL CHECKS</p>	MEN X MINUTES	
<p>GROUND HANDLING AND GROUND TEST EQUIPMENT</p>		
<p>SPECIAL TOOLS TO REMOVE OR SERVICE</p>		
<p>REMARKS</p>		