

SECRET

QCX
Avro
CF105
Misc-9

FILE IN VAULT
UNCLASSIFIED

19

ANALYZED

Twin Engine
SUPERSONIC ALL-WEATHER
FIGHTER
CF - 105



A. V. ROE CANADA LIMITED

MALTON ONTARIO

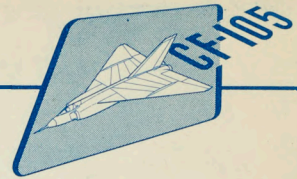

ANALYZED

SECURITY WARNING

This document is classified SECRET and is intended solely for the use of the recipient and may be used only in connection with work carried out for, or on behalf of, the Government of Canada.

THE UNAUTHORIZED RETENTION OR DESTRUCTION OF THIS DOCUMENT IS PROHIBITED.

At all times this Document must be handled in accordance with the existing regulations pertaining to information classified SECRET published by the Canadian or U. S. Governments.

This brochure has been specially prepared for the Canadian and United States Governments and their attendant Services. The information contained herein is the property of A. V. Roe Canada Limited and the Canadian Government and the recipient shall not transfer, copy, reprint, divulge or use any portion of it without the prior written consent of A. V. Roe Canada Limited.

This is Copy Number 39
Issued to: F/L. I.S. MAC LEISH ~~MAC KEITH~~ R.C.A.F.
Date: 23 SEPT 1954.

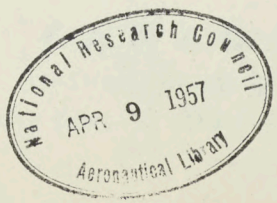

45729

8778719

AVRO CANADA

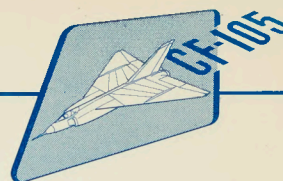

CF-105
TWIN ENGINE
SUPERSONIC ALL-WEATHER
FIGHTER

JULY 1954

A. V. ROE CANADA LIMITED

AIRCRAFT DIVISION

MALTON - ONTARIO

SECRET

AVRO CANADA

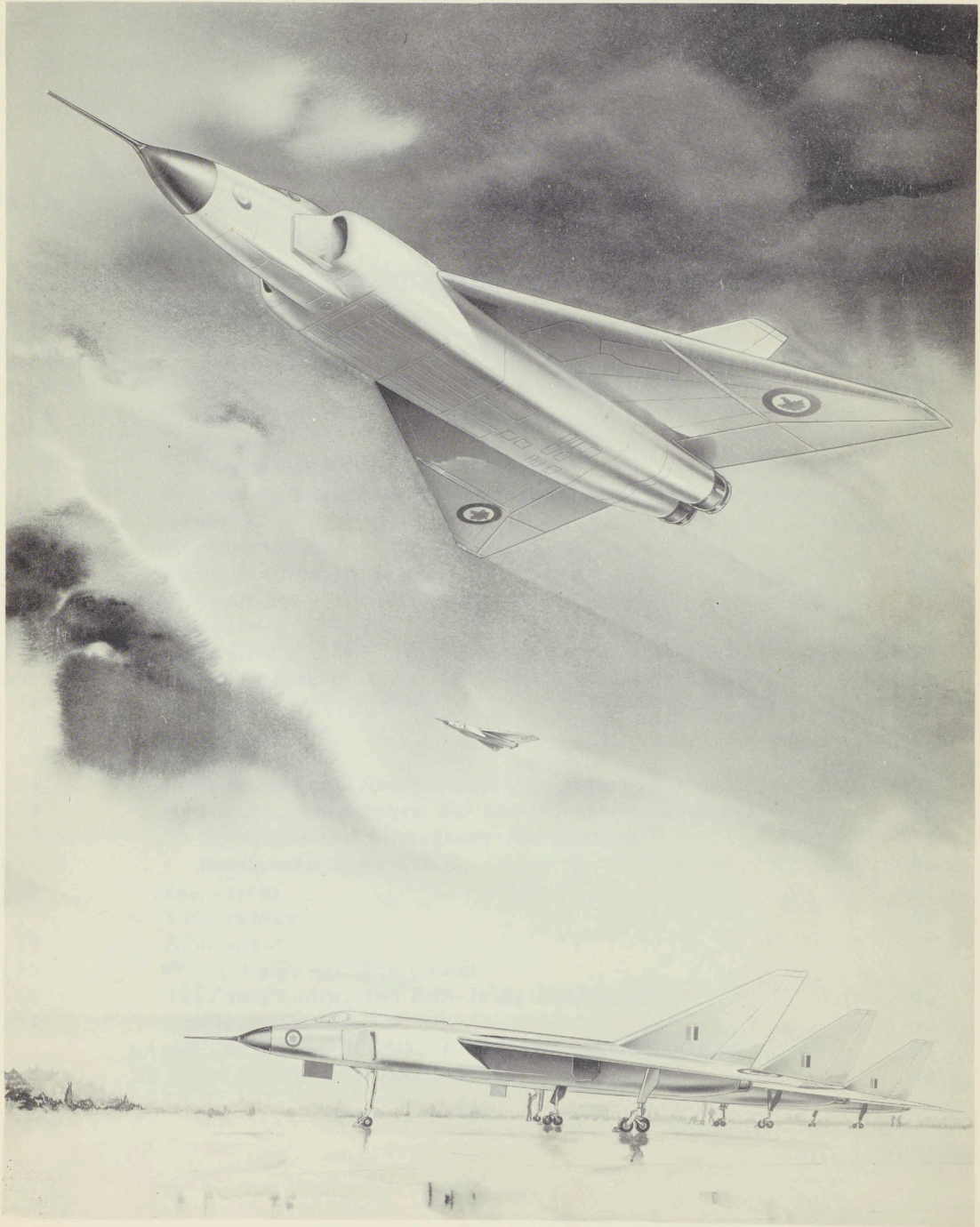
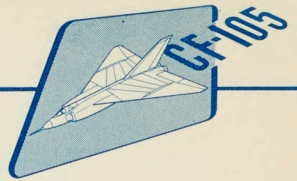

CF-105 SUPERSONIC ALL-WEATHER FIGHTER

SECRET

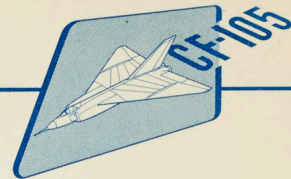

TABLE OF CONTENTS

PARA.	SUBJECT	PAGE
1	SCOPE	1
2	APPLICABLE SPECIFICATIONS AND OTHER PUBLICATIONS	1
3	REQUIREMENTS:	3
3.1	Characteristics	3
3.1.2	Performance	3
3.1.3	Weights	27
3.1.4	Center of Gravity	30
3.1.5	Areas	30
3.1.6	Dimensions and General Data	30
3.1.7	Control Surface and Corresponding Control Movements	32
3.2	General	32
3.3	Aerodynamics	38
3.4	Structure Design Criteria	52
3.5	Wing Group	55
3.6	Tail Group	58
3.7	Body Group	59
3.8	Alighting Gear	61
3.10	Surface Control System	64
3.11	Engine Section	65
3.12	Propulsion	67
3.14	Instruments and Navigational Equipment	76
3.15	Hydraulic, Emergency Air and Pneumatic Systems	76
3.15.1	Hydraulic and Emergency Air Systems	76
3.15.2	Pneumatic System	80
3.16	Electrical	81
3.17	Electronics	86
3.18	Armament	92
3.19	Furnishings and Equipment	94
3.20	Air Conditioning and Anti-Icing Equipment	96
3.22	Auxiliary Gear	97
4	SAMPLING, INSPECTION AND TEST PROCEDURES	97
5	PREPARATION FOR DELIVERY	97

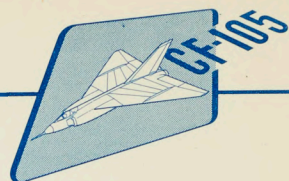
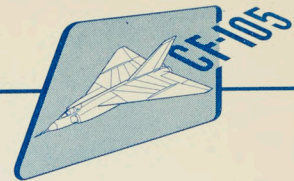

TABLE OF CONTENTS (Cont'd)

LIST OF ILLUSTRATIONS

FIG. NO.	TITLE	PAGE
1	3 View General Arrangement	2
2	Level Flight True Air Speed	10
3	Level Flight Mach Number	11
4	Maximum Steady Rate of Climb	12
5	Time to Height from Engine Start	13
6	Distance to Height from Engine Start	14
7	Fuel to Height from Engine Start	15
8	Take-off Distances - Sea Level	16
9	Take-off Distances - 3,000 Ft.	17
10	Landing Distances	18
11	High Speed Mission	19
12	Maximum Range Mission	20
13	Long Range Ferry Mission	21
14	Acceleration Time in Level Flight	22
15	Manoeuvrability Performance at Altitude	23
16	Performance Flight Envelope at Sea Level	24
17	Performance Flight Envelope at 40,000 Ft.	25
18	Performance Flight Envelope at 50,000 Ft.	26
19	Equipment Arrangement	33
20	CF-105 Component Breakdown	34
21	Profile Drag Coefficient	42
22	Drag Efficiency	44
23	Effect of Elevator Deflection on Minimum Drag Coefficient	45
24	Lift at Minimum Drag	46
25	Structural Flight Envelope at Sea Level	53
26	Structural Flight Envelope at 30,000 Ft.	54
27	Structure Arrangement	56
28	Engine Installation and Removal	66
29	Engine Airflow and Cooling	70
30	Fuel System - Diagrammatic of Fuel Feed and Transfer	72
31	Fuel System - Diagrammatic of Fuel Pressurization	73
32	Fuel System - Diagrammatic of Refuelling and Defuelling	74
33	Hydraulics Schematic Flying Controls System	78
34	Hydraulics Schematic Utility System	79
35	Low Pressure Pneumatic System Schematic	82
36	Electrics Circuit Diagram	83
37	Armament and Electronic Equipment Installations - Falcon	93
38	Armament and Electronic Equipment Installations - Sparrow 2	95



1 SCOPE

1.1 Details of the following airplane are covered in this brochure:-

Service Model Designation	Supersonic, all-weather fighter
Designer's Name and Model	
Designation	A. V. Roe Canada Ltd., - CF-105
Number and Places for Crew	Two (2)-Pilot & Radar Operator
Number and Kind of Engines	<u>Prototypes</u>

Two Curtiss-Wright Corp.,
turbojet engines, YJ. 67-W-1
fitted with afterburners

Production Aircraft

To be decided.

1.1.1 The main role of the aircraft is high altitude, all-weather, night and day interception and destruction of enemy bomber aircraft.

1.1.2 The secondary role of the aircraft is low altitude, all-weather, night and day interception and destruction of enemy bomber aircraft. However, the aircraft will be designed to fulfil its primary role and limitations will be accepted in the fulfilment of its secondary role.

2 APPLICABLE SPECIFICATIONS AND OTHER PUBLICATIONS

2.1 Specifications and publications used in the preparation of this brochure are as follows:-

- (a) Handbook of Instructions for Aircraft designers, ARDCM 80-1 Edition including revisions up to and including January 1954.
- (b) Air Force (USAF) Model Specification MIL-I-6252 B(ASG) dated 15 April, 1953.
- (c) Manual of aircraft requirements for the Royal Canadian Air Force CAP 479, dated 20 May, 1954.
- (d) Engine Model specification YJ. 67-W-1, Curtiss-Wright W. A. D. Specification No. 880-A, revised 6 February, 1952.
- (e) Installation data, YJ. 67-W-1 turbojet engine, Curtiss-Wright publication A. E. D. -26-B, dated November, 1953.

312
190

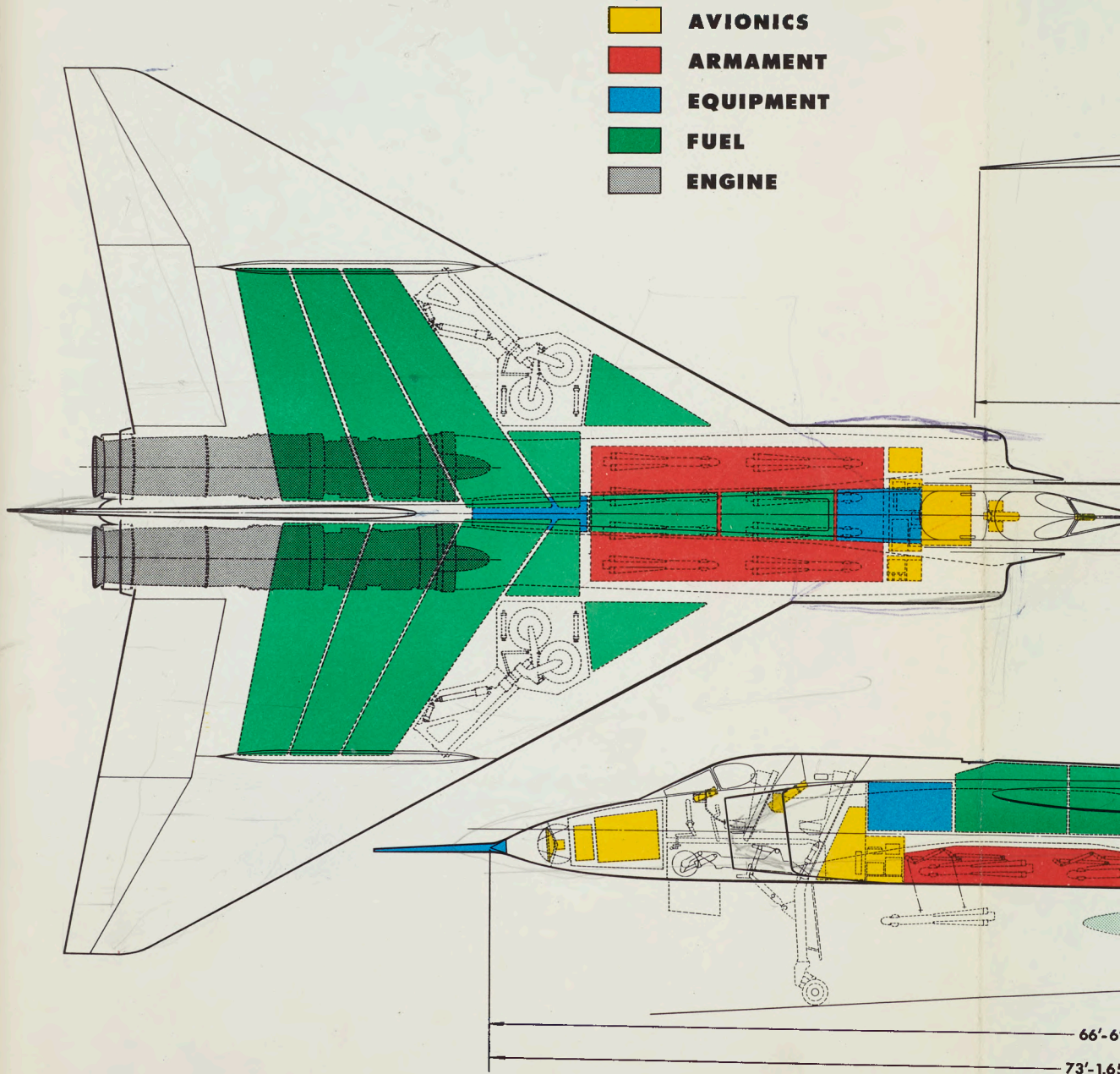

FIG. 1 3 VIEW GENERAL ARRANGEMENT

AVIONICS
ARMAMENT
EQUIPMENT
FUEL
ENGINE

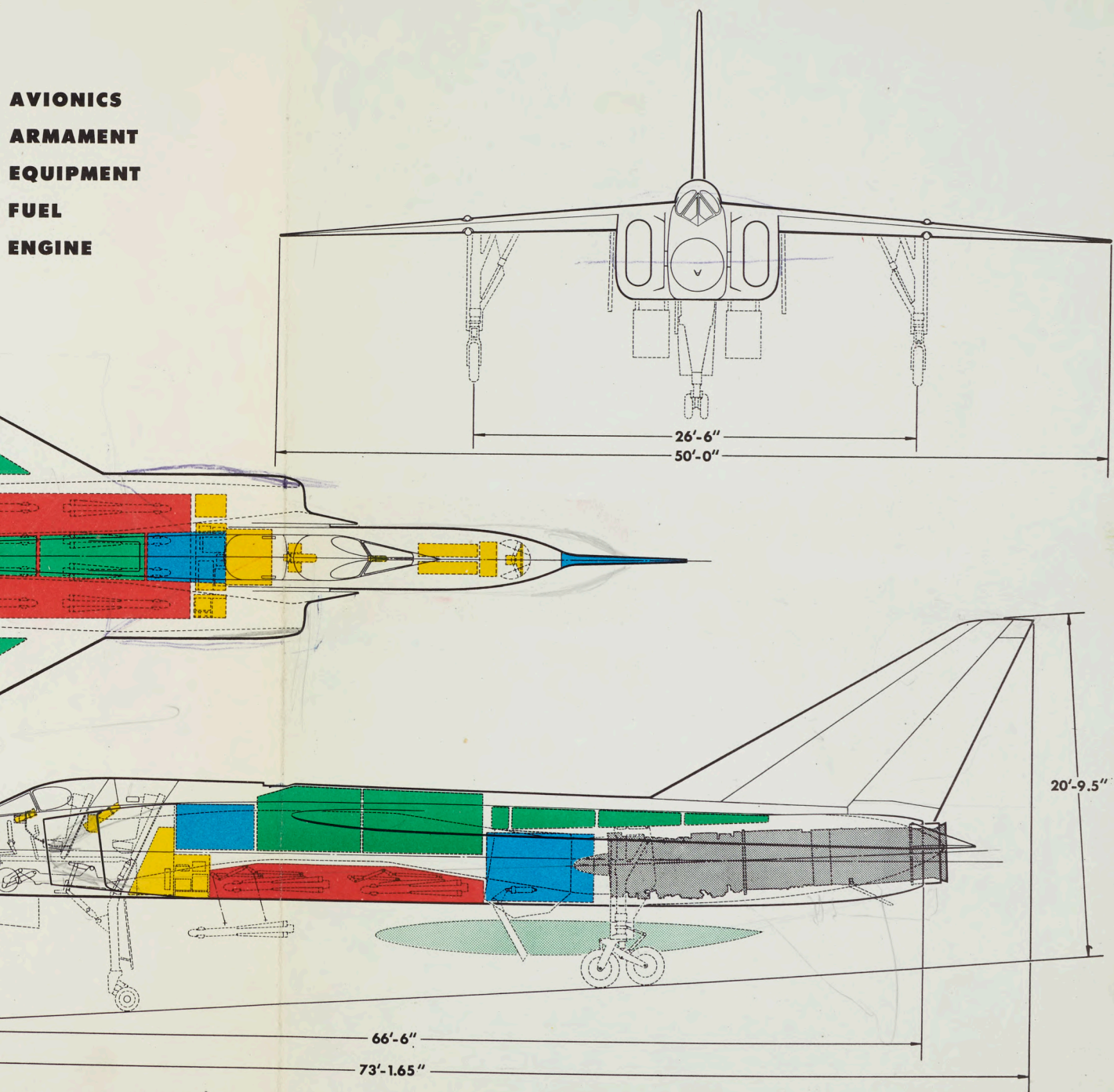
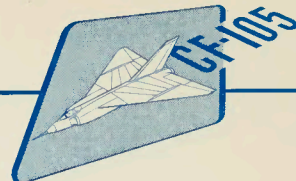

FIG. 1 3 VIEW GENERAL ARRANGEMENT



3 REQUIREMENTS

3.1 Characteristics:

3.1.1 Refer to Figure 1 on the preceding page for information on the configuration of the airplane.

3.1.2 Performance:

3.1.2.1 Tabulated Performance:

TABLE 1

PERFORMANCE UNDER N. A. C. A. STANDARD ATMOSPHERIC CONDITIONS

True Air Speed in Level Flight at Sea Level at Combat Weight (45,000 lb.):	
Maximum Thrust with Afterburners	780 knots
Military Thrust	655 knots
True Air Speed in Level Flight at 50,000 ft. Altitude at Combat Weight (45,000 lb.):	
Maximum Thrust with Afterburners	1240 knots
Combat Ceiling (rate of climb = 500 f. p. m.) at Combat Weight (45,000 lb.):	
Maximum Thrust with Afterburners at Mach No. = 1.50 ...	61,500 ft.
Maximum Thrust with Afterburners at Mach No. = 1.75 ...	62,500 ft.
Steady Rate of Climb at Sea Level at Combat Weight (45,000 lb):	
Maximum Thrust with Afterburners at Mach No. = .95	46,500 f. p. m.
Military Thrust at Mach No. = .95	11,700 f. p. m.
Steady Rate of Climb at 50,000 ft. Altitude at Combat Weight (45,000 lb.):	
Maximum Thrust with Afterburners at Mach No. = 1.50 ...	10,500 f. p. m.
Time to 50,000 ft. Altitude and Mach No. = 1.50 from Engine start at normal take-off gross weight = 51,048 lb.	
Maximum Thrust with Afterburners	4.3 min.

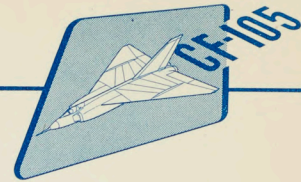

TABLE 1 (CONTINUED)

Combat Load Factor at Combat Weight (45,000 lb.):	
Maximum Thrust with Afterburners at Mach No. =1.50 at 50,000 ft.	1.78 g.
Maximum Thrust with Afterburners at Mach No. =1.75 at 50,000 ft.	1.90 g.
Take-off Distance over 50 ft. Obstacle at Sea Level at normal take-off gross weight (51,048 lb.)	
Maximum Thrust with Afterburners	3000 ft.
Military Thrust	5300 ft.
Landing Distance over 50 ft. Obstacle at Sea Level at Combat Weight (45,000 lb.)	
	5900 ft.
True Stalling Speed in Landing Configuration at Sea Level at Combat Weight (45,000 lb.)	
	104 knots
Combat Radius of Action with Combat at 50,000 ft. Altitude:	
High Speed Mission (Table 3 - RCAF Spec AIR-7-4)	200 naut. mi.
High Speed Mission (Full Internal Fuel)	436 naut. mi.
Maximum Range Mission (Table 4 - RCAF Spec. AIR-7-4) ...	
Maximum Range Mission (Full Internal Fuel)	306 naut. mi.
	655 naut. mi.
Ferry Range Mission (Table 5 - RCAF Spec. AIR-7-4)	1869 naut. mi.

3.1.2.1.1 Engine Performance:

TABLE 2 - PERFORMANCE RATINGS OF YJ. 67-W-1 ENGINE WITH
AFTERBURNER UNDER N.A.C.A. STANDARD SEA LEVEL CONDITIONS

Condition	Low Pressure Compressor R. P. M.	Thrust Lb.	Sp. Fuel Consumption Lb./Hr./Lb. Thrust
Maximum with A/B	6,175	21,500	2.05
Military	6,175	13,200	.795
Normal	6,175	11,700	.760

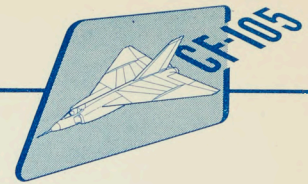

3.1.2.1.2 Combat Radius - High Speed Mission:

TABLE 3 - COMBAT RADIUS OF ACTION - HIGH SPEED MISSION
(TO R.C.A.F. SPEC. AIR-7-4)

Condition	Distance Naut. Mi.	Time Mins.	Fuel Consumed Lb.	Aircraft Weight Lb.
A. Start Weight	-	-	-	51,048
B. Engine Start	-	.50	100	50,948
C. Take-off to Unstick, Mil. Thrust	-	.36	132	50,816
D. Accel. to .75 M.N. Mil. Thrust to .95 M.N. Max. Thrust with A/B	7.4	1.26	730	50,086
E. Climb at M.N. = .95 to 40,000', Max. Thrust with A/B	12.3	1.46	1560	48,526
F. Accel. to 1.5, Max. Thrust with A/B	15.7	1.35	895	47,631
G. Climb to 50,000', 1.5 M.N. Max. Thrust with A/B	10.5	.70	460	47,171
H. Cruise out at 50,000', 1.5 M.N.	154.1	10.70	2735	44,436
I. Combat 50,000', 1.5 M.N., Max. Thrust with A/B	-	5.00	2540	40,840*
J. Descend to 40,000'	-	1.10	36	40,804
K. Cruise Back at speed for Max. Range	200.0	22.00	1660	39,144
L. Stack at 40,000' at speed for Max. Endurance	-	15.00	1000	38,144
M. Descend to S.L.	-	4.63	192	37,952
N. Land with 5 Min. Fuel (Max. End.)	-	5.00	580	37,372
TOTAL	400	69.06	12,620	

Combat Radius of Action = 200 naut. mi.

*1,056 lb. of armament fired

NOTE: With full internal fuel the combat radius is increased to 436 naut. mi.

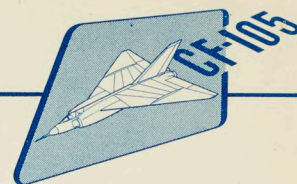

3.1.2.1.3 Combat Radius - Maximum Range Mission:

TABLE 4 - COMBAT RADIUS OF ACTION - MAXIMUM RANGE MISSION
(TO R.C.A.F. SPEC. AIR-7-4)

Condition	Distance Naut. Mi.	Time Mins.	Fuel Consumed Lb.	Aircraft Weight Lb.
A. Start Weight	-	-	-	51,048
B. Engine Start	-	.50	100	50,948
C. Take-off to Unstick, Mil. Thrust	-	.36	132	50,816
D. Accel. to .95 M.N., Mil. Thrust	11.6	1.71	675	50,141
E. Climb at .95 M.N., Mil. Thrust	50.0	5.45	1320	48,821
F. Cruise Out at 40,000' (Max. Range)	220.0	24.20	2155	46,666
G. Accel. to 1.5 M.N. at 40,000' Max. Thrust with Afterburner	15.0	1.28	850	45,816
H. Climb at 1.5 M.N. to 50,000', Max. Thrust with Afterburner	9.4	.65	440	45,376
I. Combat at 1.5 M.N. at 50,000', Max. Thrust with Afterburner	-	5.00	2540	41,780*
J. Descend to 40,000' (Idling R.P.M.)	-	1.10	36	41,744
K. Cruise Back at 40,000' (Max. Range)	306.0	33.60	2600	39,144
L. Stack at 40,000' (Max. Endurance)	-	15.00	1000	38,144
M. Descend to Sea Level	-	4.63	192	37,952
N. Land with 5 Min. Fuel (Max. End.)	-	5.00	580	37,372
TOTAL	612	98.48	12,620	

Combat Radius of Action = 306 naut. mi.

*1,056 lb. of armament fired

NOTE: With full internal fuel the combat radius increases to 655 naut. mi.

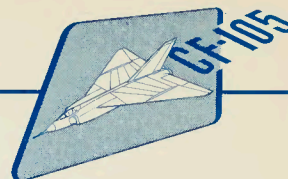

3.1.2.1.4 Ferry Range Mission with Full Internal Fuel plus 500 Imp. Gall. under-fuselage external tank.

TABLE 5 - FERRY RANGE MISSION (TO R.C.A.F. SPEC. AIR-7-4.)

Condition	Distance Naut. Mi.	Time Mins.	Fuel Consumed Lb.	Aircraft Weight Lb.
A. Start Weight	-	-	-	62,808
B. Engine Start	-	.50	100	62,708
C. Take-off to Unstick, Mil. Thrust	-	.54	210	62,498
D. Accel. to .95 M.N., Mil. Thrust	16.0	2.28	935	61,563
E. Climb to 40,000', Mil. Thrust	73.0	8.0	1,890	59,673
F. Cruise at 40,000', (Max. Range)	1,780	198.05	18,972	40,701
G. Stack at 40,000' (Max. End.)	-	15.0	1035	39,666
H. Descend to S. L. (Idling)	-	4.63	198	39,468
I. Land with 5 Min. Fuel (Max. End.)	-	5.0	600	38,868
TOTAL	1,869	234	23,940	

Ferry Range = 1869 naut. mi.

NOTE: Armament, and external tank
are carried throughout mission.

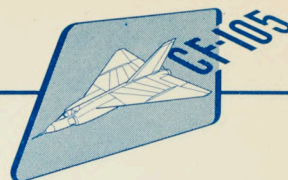

3.1.2.1.5 Combat Fuel Allowances: The following table sets forth the combat fuel allowance based on 5 minutes at a Mach number of 1.5 at maximum thrust, together with the equivalent cruise range at a Mach number of 1.5 at 50,000 ft. and at maximum range speed at 40,000 ft. Comparative allowance for turning through 180 degrees at the respective altitudes is also given.

TABLE 6 - COMBAT FUEL ALLOWANCES AT COMBAT WEIGHT (45,000lb.)

Altitude Ft.	Combat Fuel Allowance - Lb.	Range at M = 1.5 at 50,000 ft. Naut. Mi.	Max. Range at 40,000 Ft. Naut. Mi.	Fuel for 180° Turn at M= 1.5 - Lb.
55,000	2,000	115	215	970
50,000	2,540	145	275	820
45,000	3,220	185	350	750
40,000	4,120	235	445	710
35,000	5,160	290	560	740

3.1.2.1.6 The performance specified herein is based on estimated specific fuel consumption of the two YJ.67-W-1 engines, each one fitted with an afterburner. Turbojet engine fuel of specific gravity = .75 is assumed for performance estimations.

3.1.2.1.7 Drag Estimate: Performance estimations specified herein are based on the drag estimate detailed in sub-paragraph 3.3

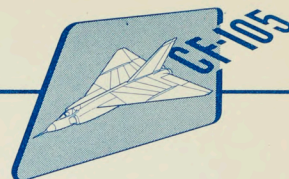

3.1.2.1.8 Combat Radius - Sea Level Mission:

TABLE 7

COMBAT RADIUS OF ACTION - SEA LEVEL MISSION
(TWO ENGINE CRUISE)

Condition	Distance Naut. Mi.	Time Mins.	Fuel Consumed Lb.	Aircraft Weight Lb.
A. Start Weight	-	-	-	51,048
B. Engine Start	-	.50	100	50,948
C. Take-Off to Unstick, Mil. Thrust	-	.36	132	50,816
D. Accel. to Cruise Speed, Mil. Thrust	4.0	.85	340	50,476
E. Cruise out at S.L. (Max. Range)	210.0	31.80	5,250	45,226
F. Accel. to .95 M.N. at S.L., Mil. Thrust	6.0	.78	310	44,916
G. Combat at .95 M.N. at S.L., Mil. Thrust	-	5.00	2,150	41,710*
H. Climb to 40,000', Mil. Thrust	40.0	4.40	1,080	40,630
I. Cruise Back at 40,000' (Max. Range)	180.0	19.75	1,486	39,144
J. Stack at 40,000' (Max. Endurance)	-	15.00	1,000	38,144
K. Descend to Sea Level	-	4.63	192	37,952
L. Land with 5 Min. Fuel (Max. End.)	-	5.00	580	37,372
TOTAL	440	88.07	12,620	

Combat Radius of Action = 220 naut. mi.

*1,056 lb. of armament fired

NOTE: With full internal fuel the combat radius increases to 433 naut. mi.

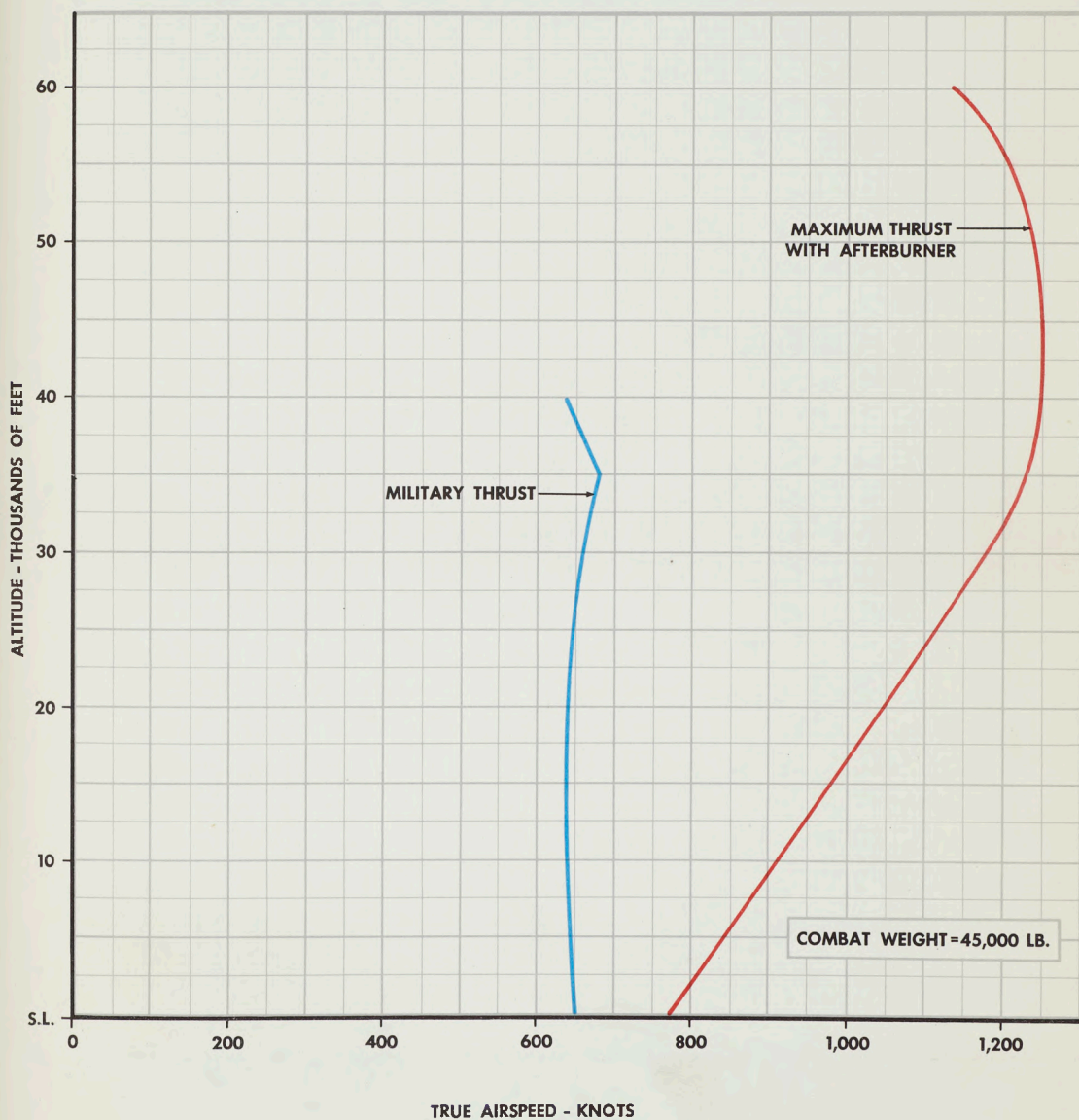
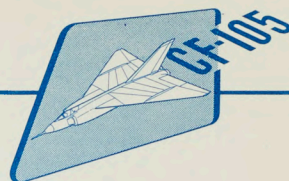

FIG. 2 LEVEL FLIGHT TRUE AIR SPEED

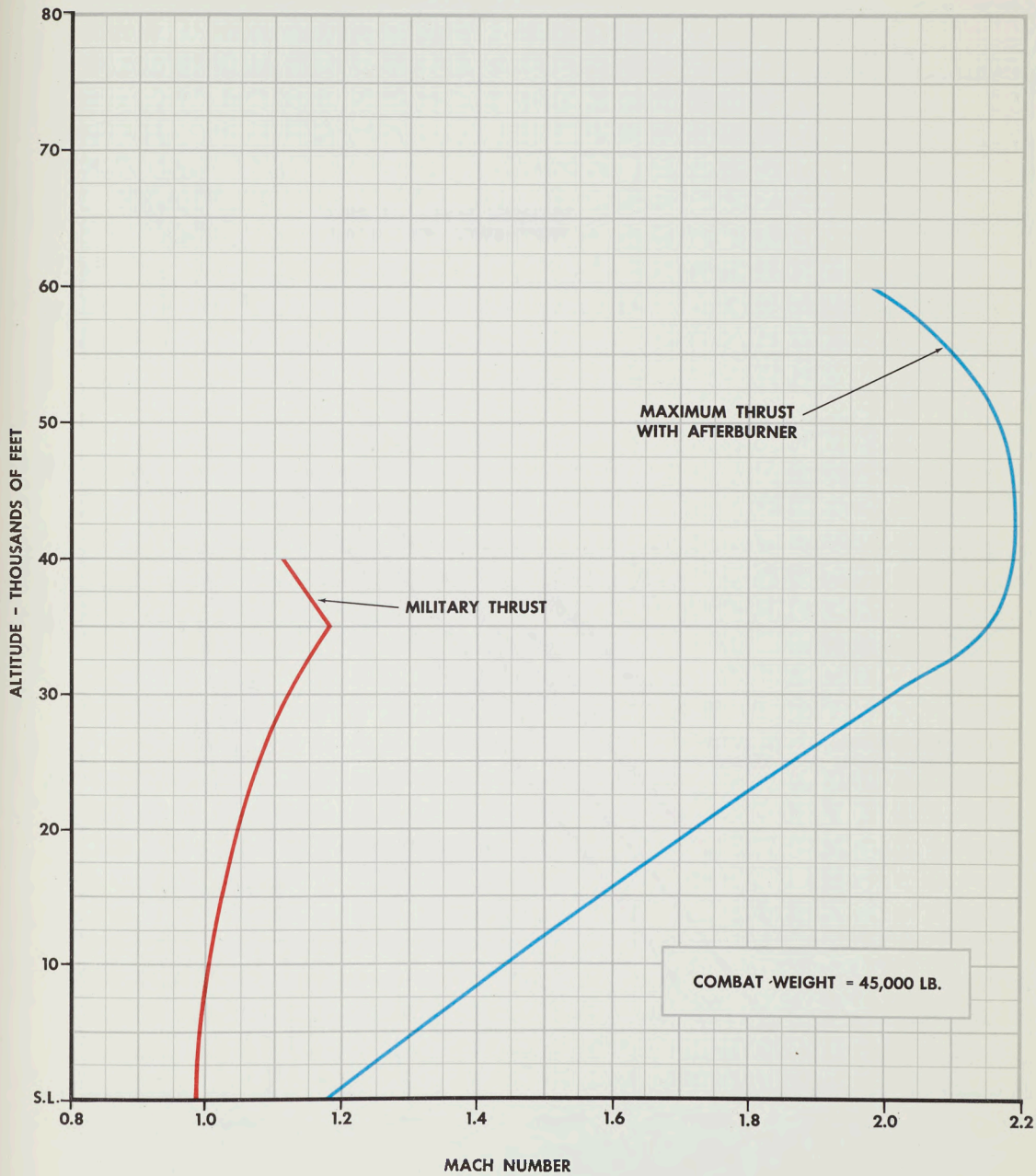
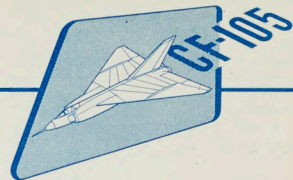

FIG. 3 LEVEL FLIGHT MACH NUMBER

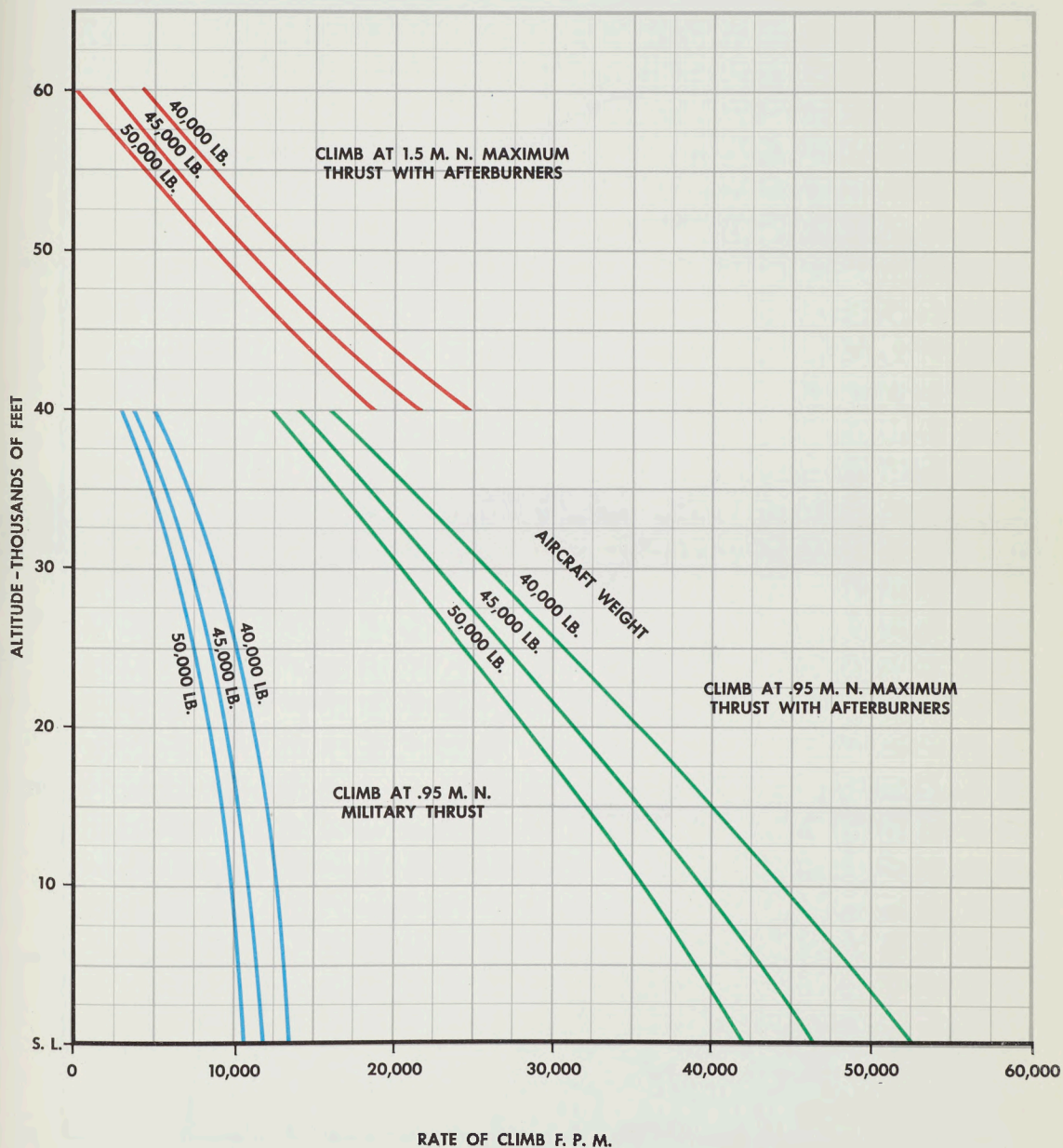
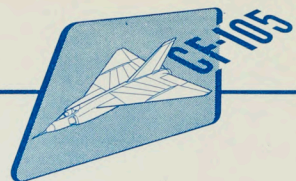

FIG. 4 MAXIMUM STEADY RATE OF CLIMB

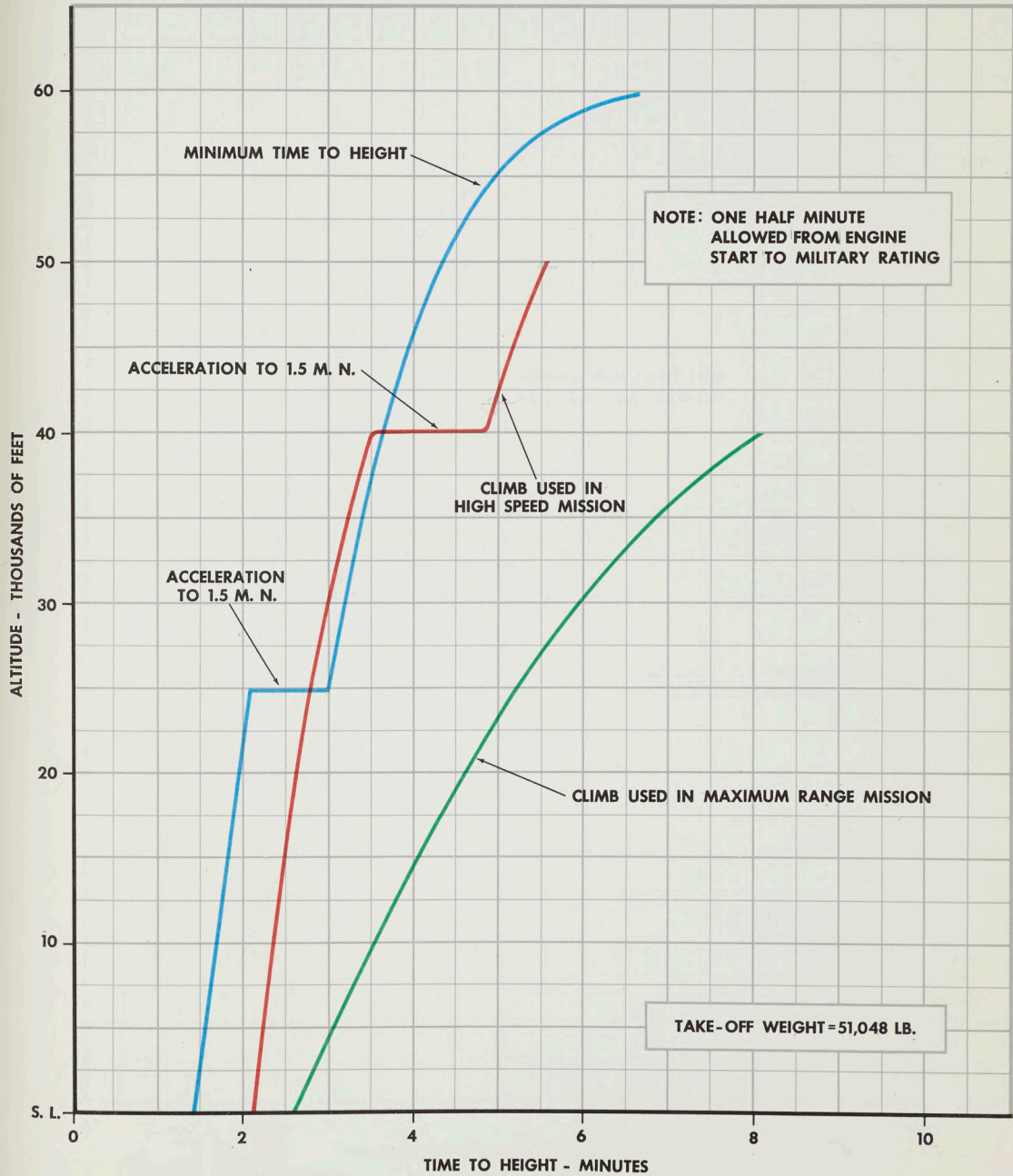
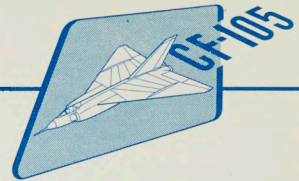

FIG. 5 TIME TO HEIGHT FROM ENGINE START

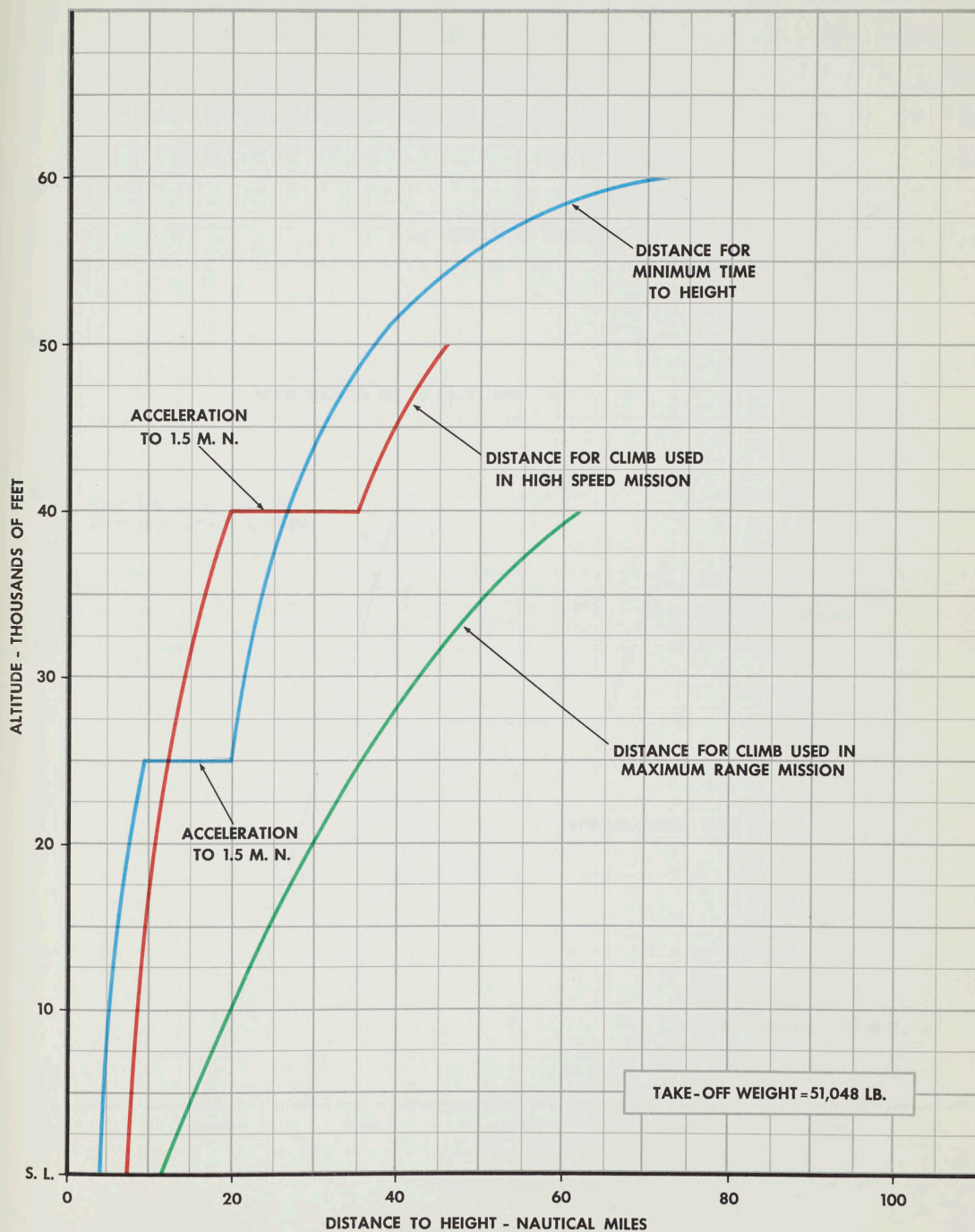
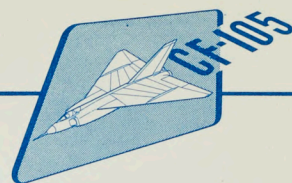

FIG. 6 DISTANCE TO HEIGHT FROM ENGINE START

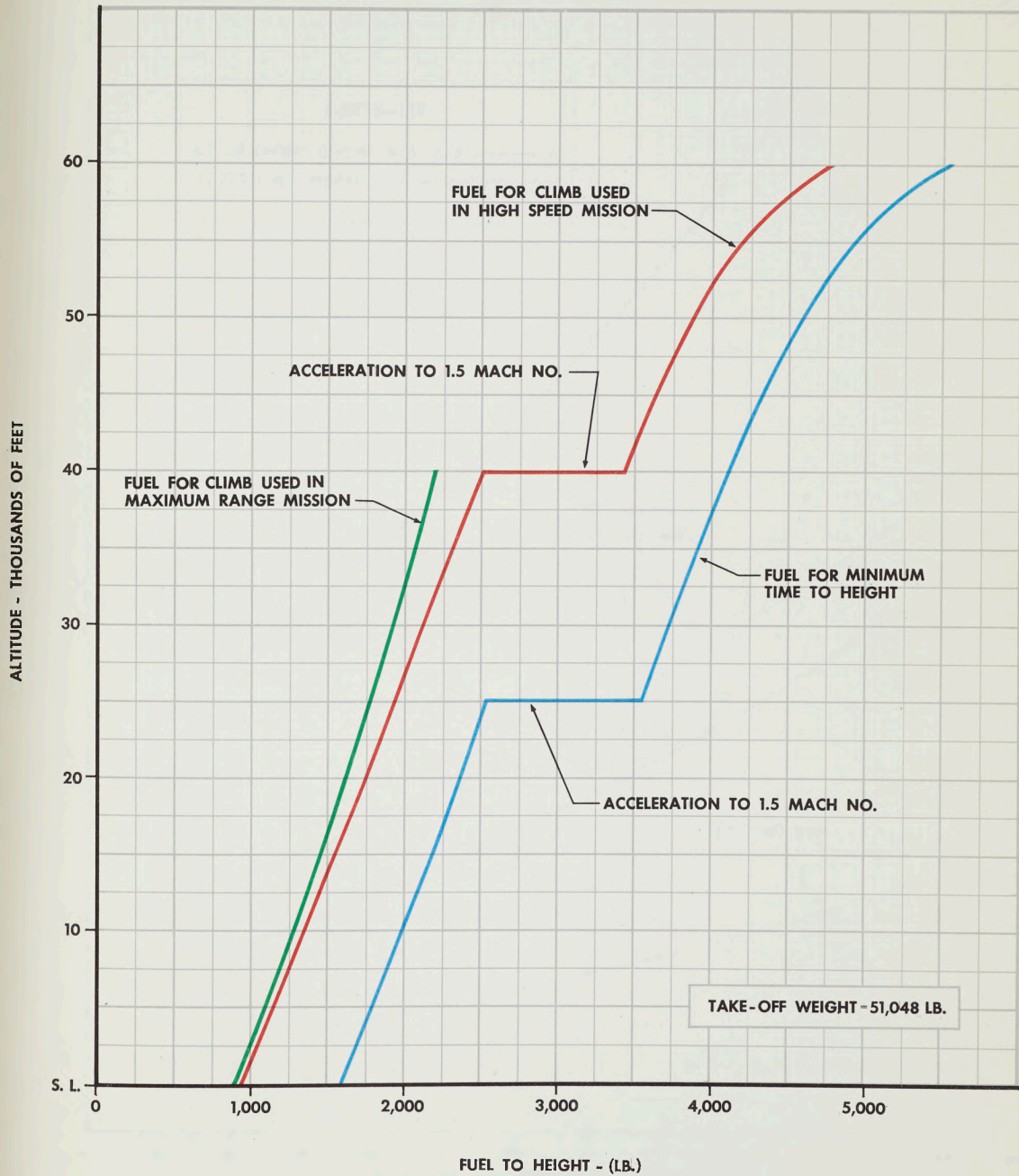
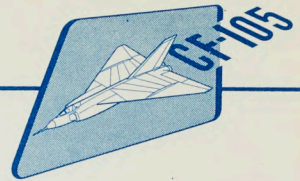

FIG. 7 FUEL TO HEIGHT FROM ENGINE START

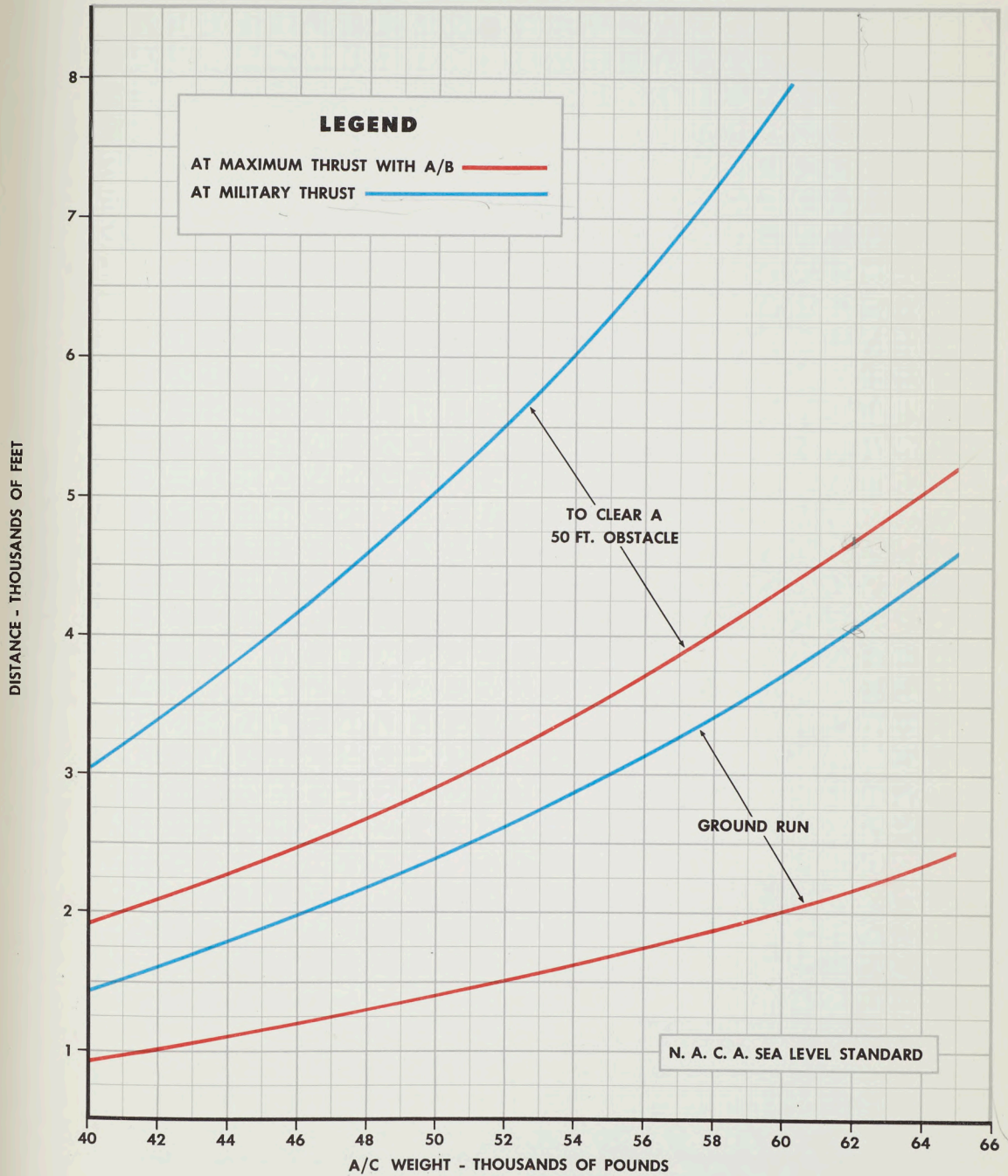
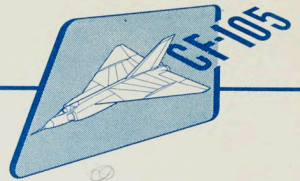

FIG. 8 TAKE-OFF DISTANCES - SEA LEVEL

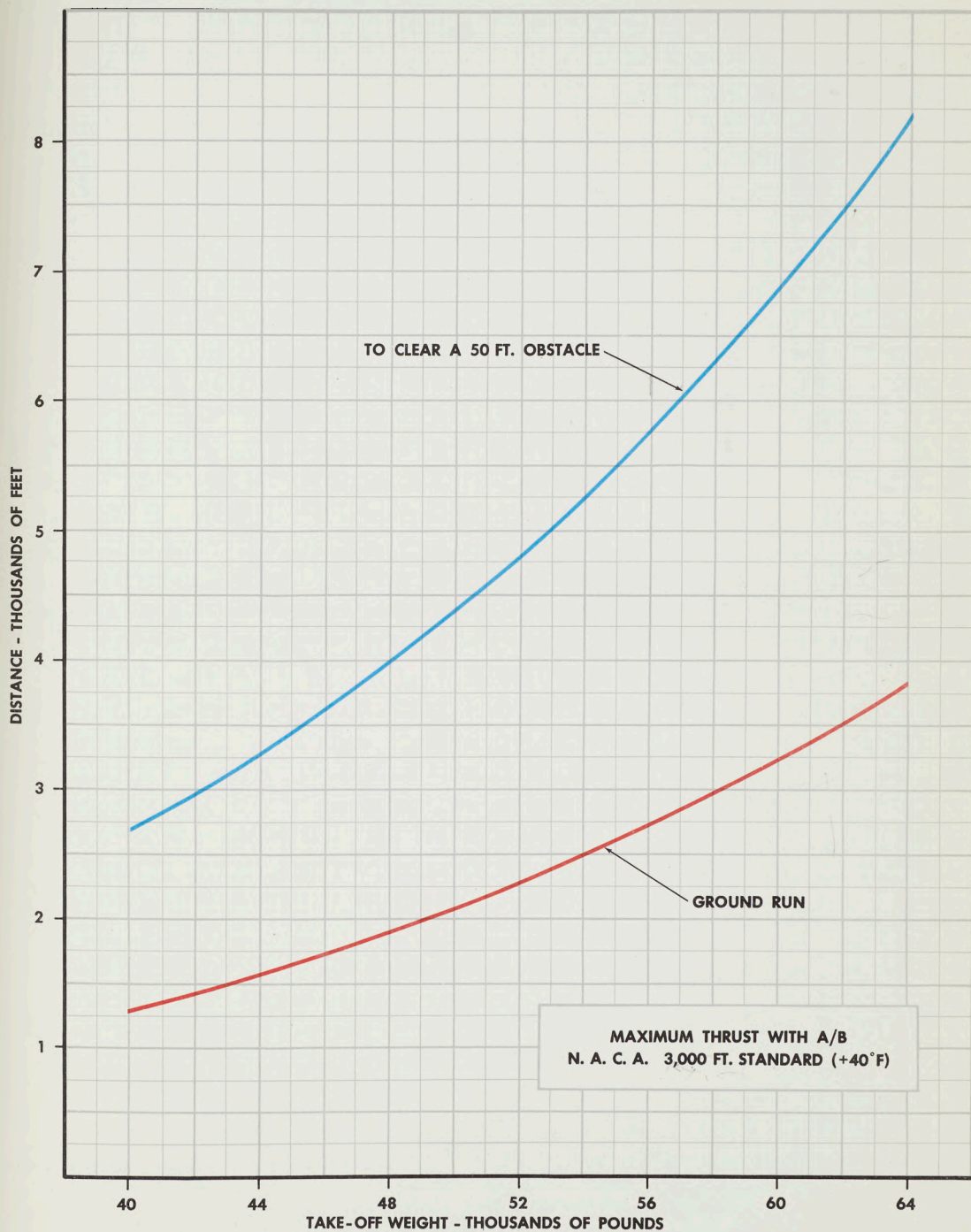
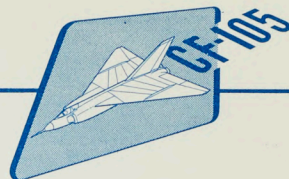

FIG. 9 TAKE-OFF DISTANCES - 3,000 FT.

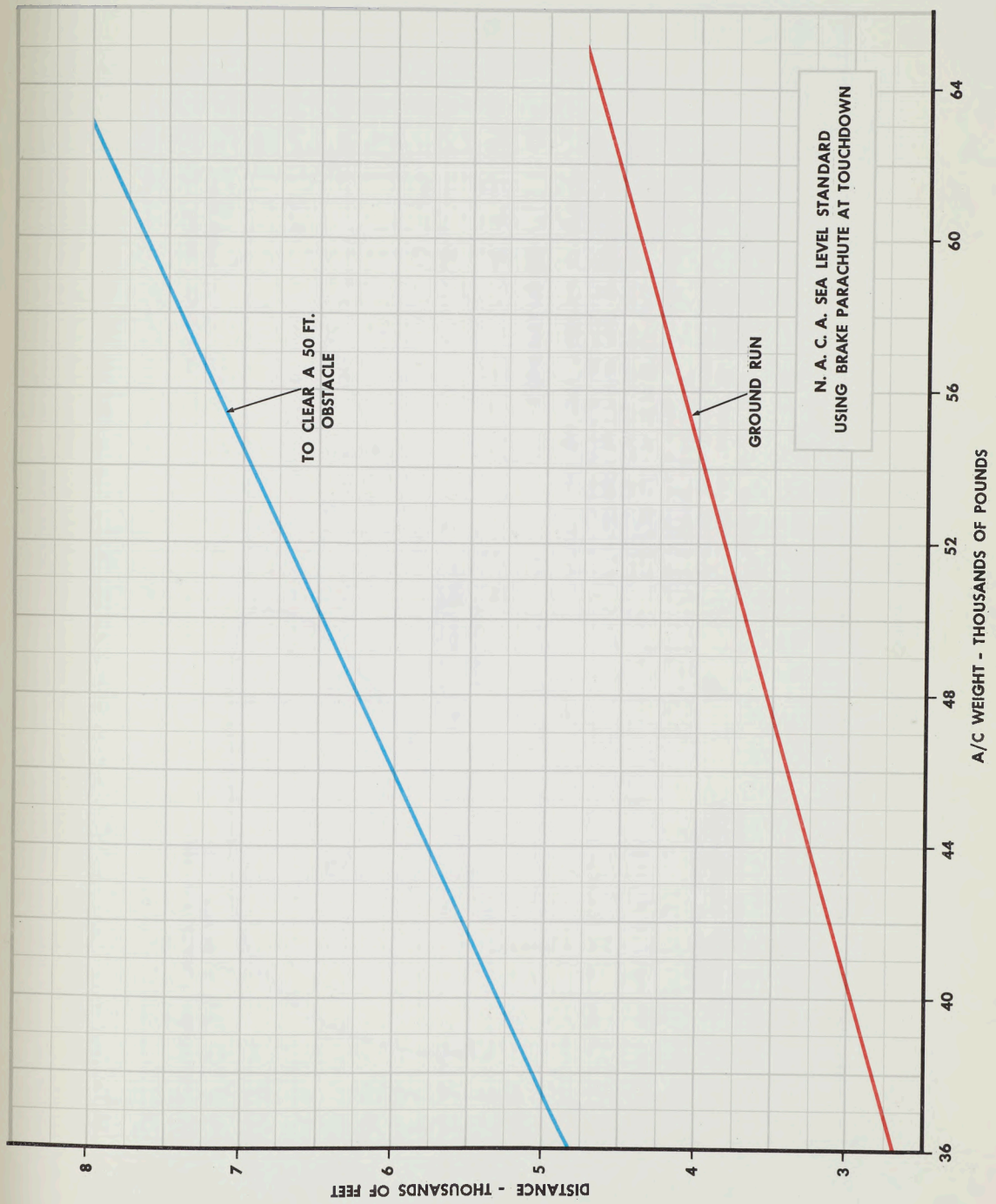
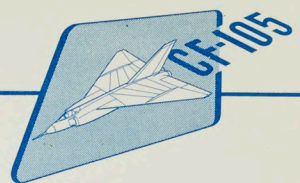

FIG. 10 LANDING DISTANCES

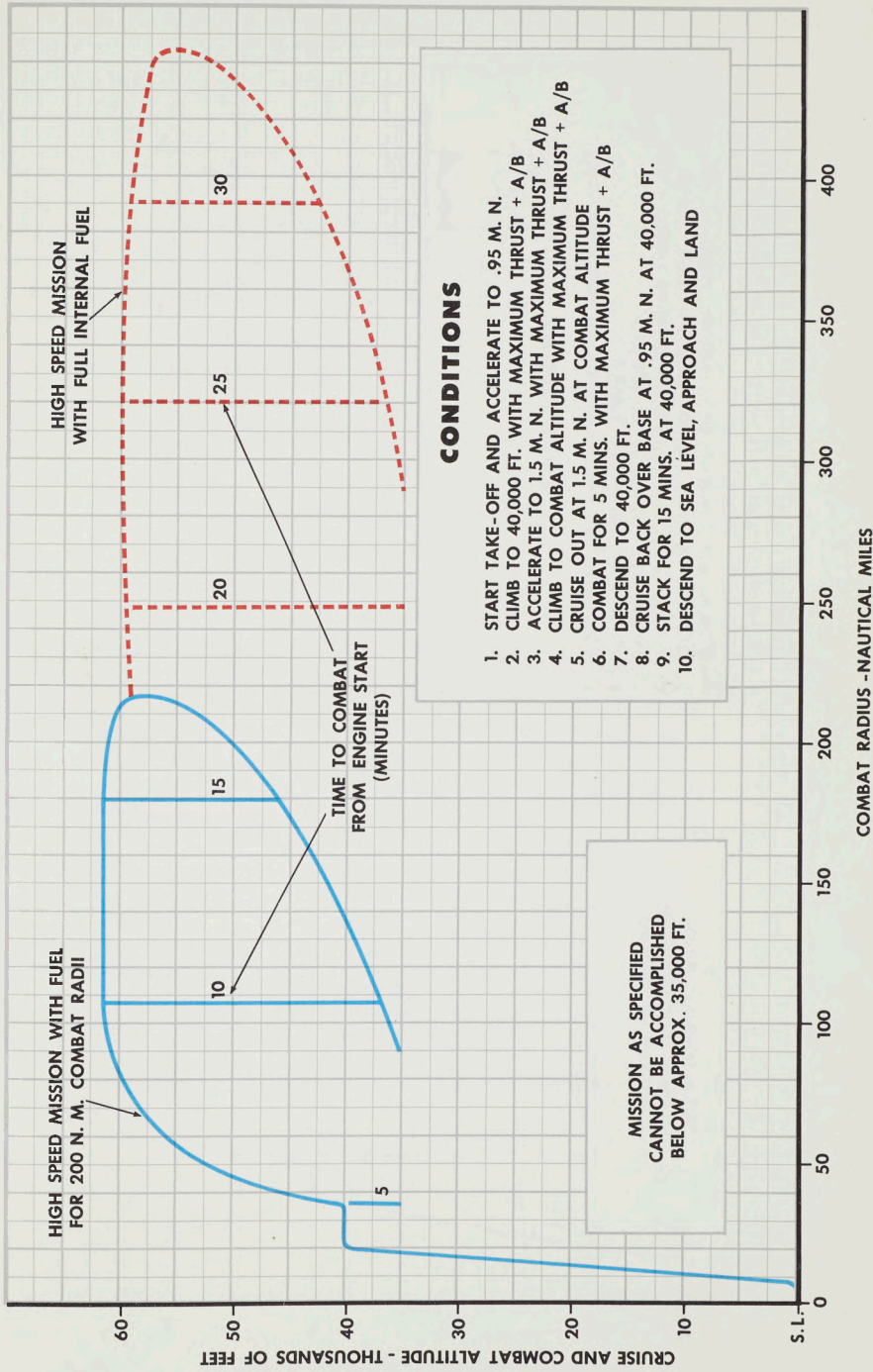
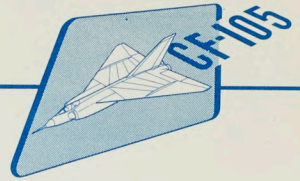

FIG. 11 HIGH SPEED MISSION

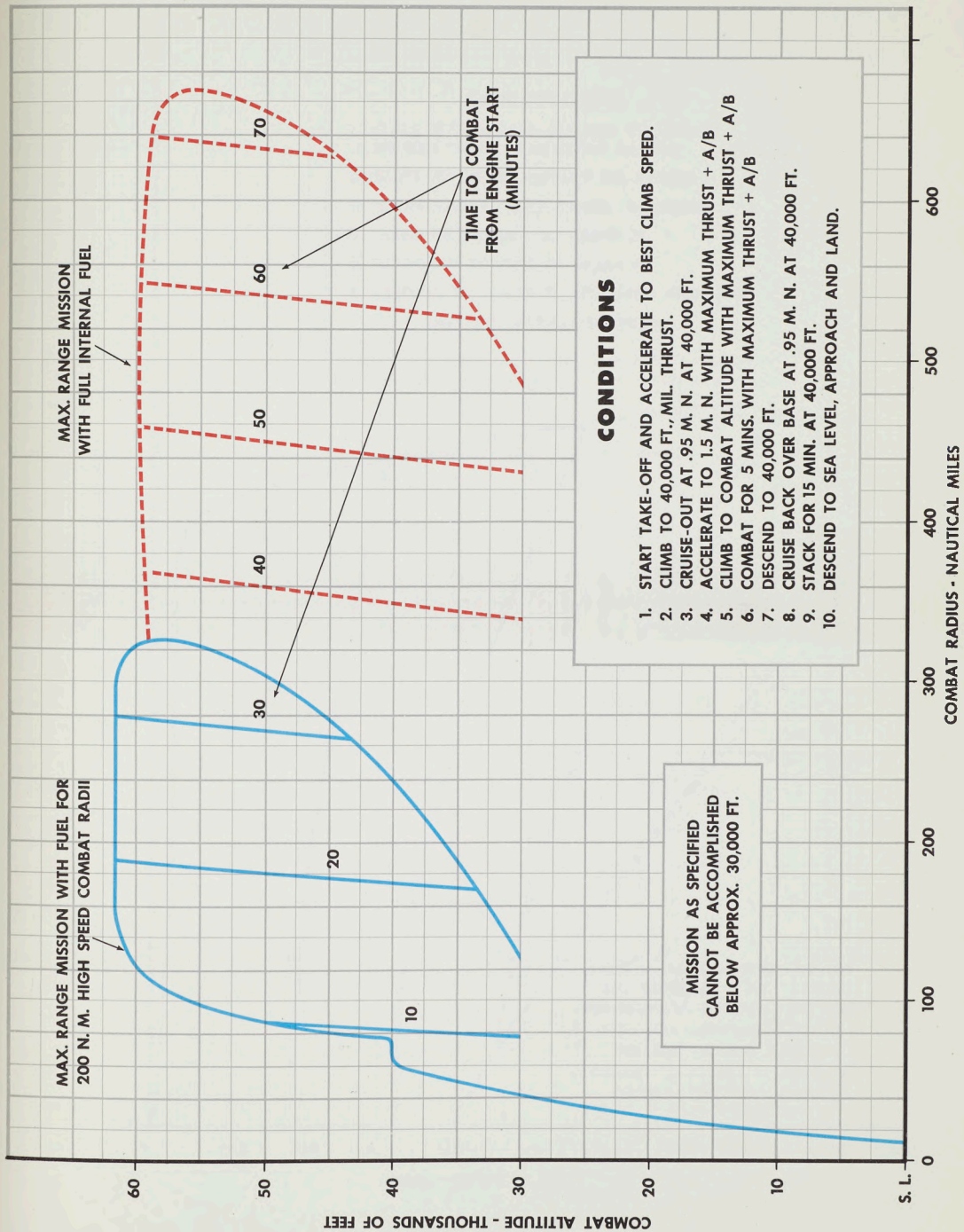
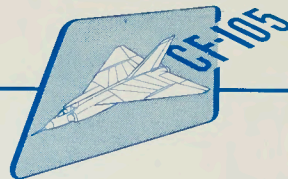

FIG. 12 MAXIMUM RANGE MISSION

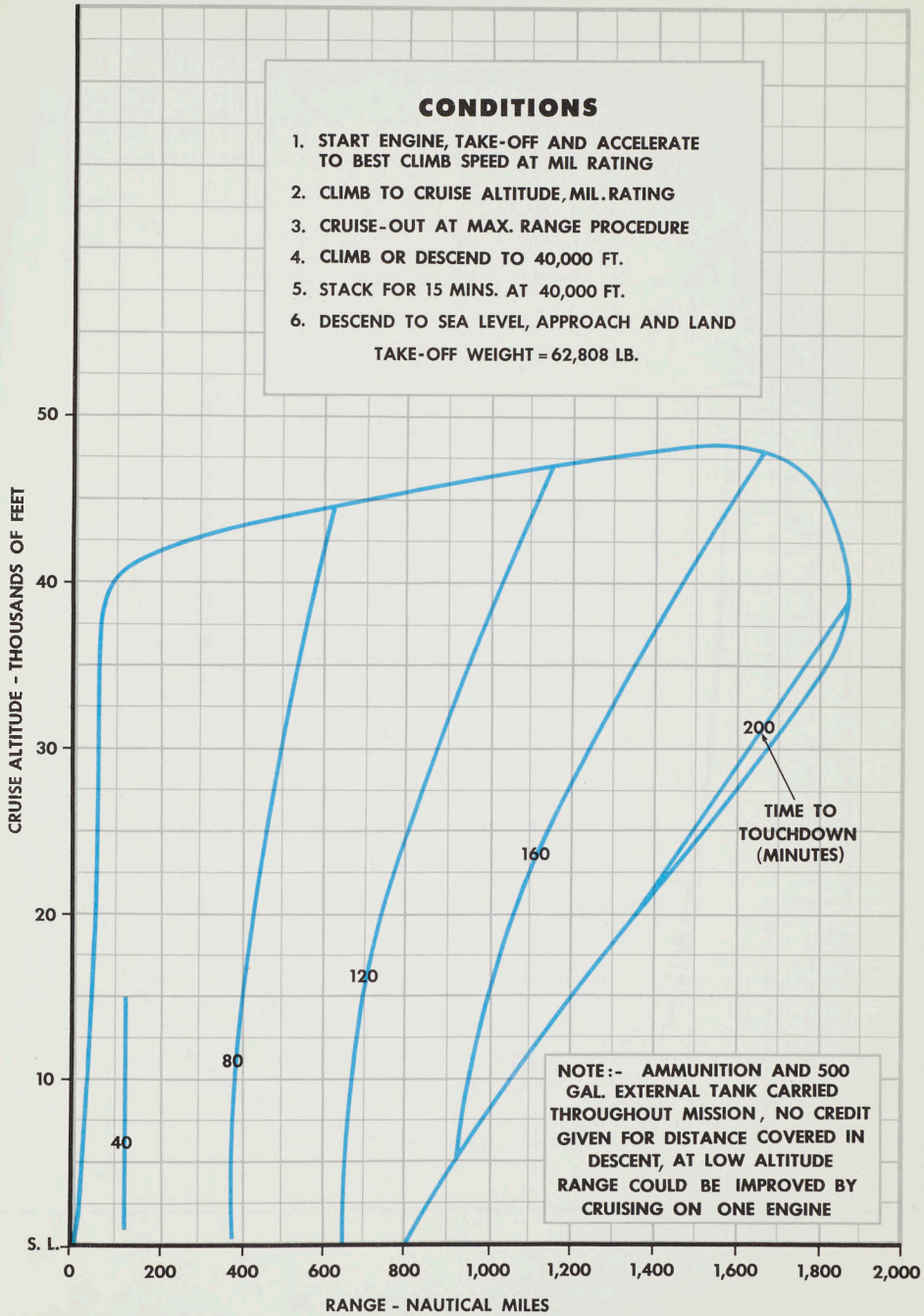
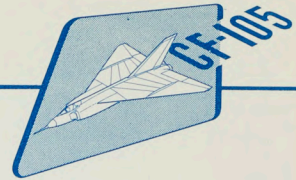

FIG. 13 LONG RANGE FERRY MISSION

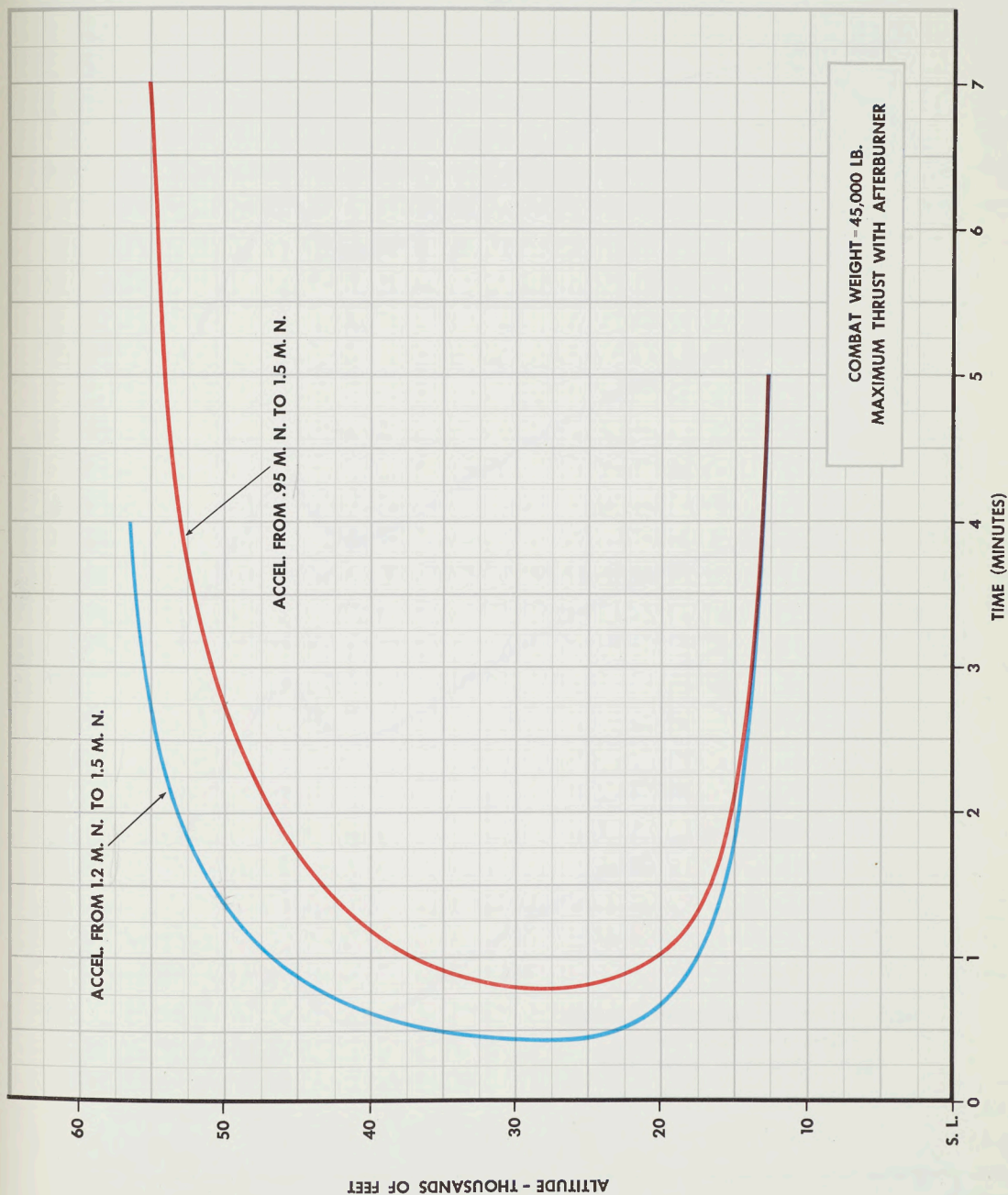
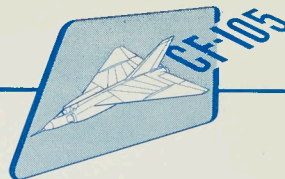

FIG. 14 ACCELERATION TIME IN LEVEL FLIGHT

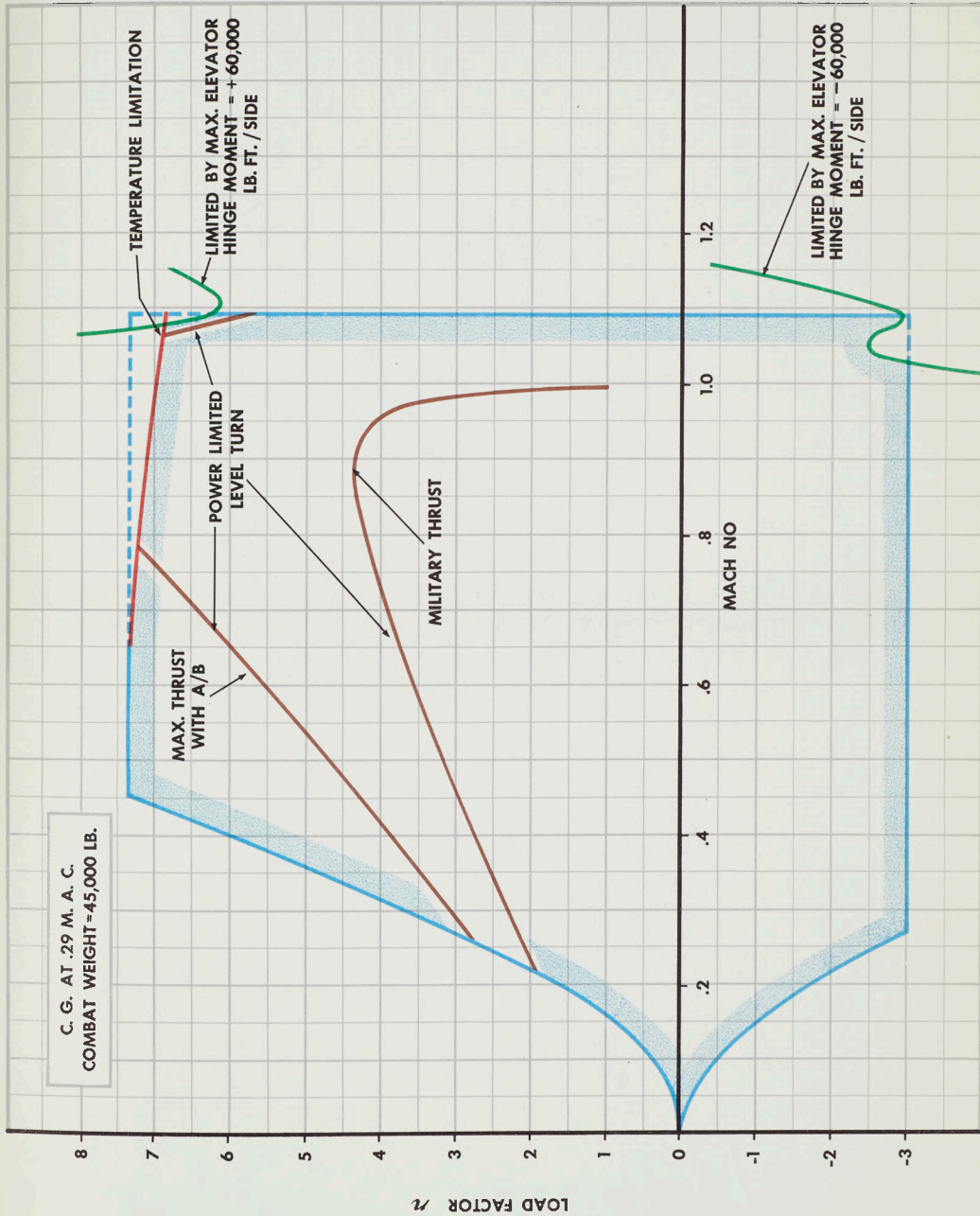
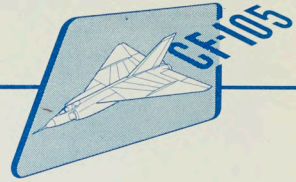

FIG. 16 PERFORMANCE FLIGHT ENVELOPE AT SEA LEVEL

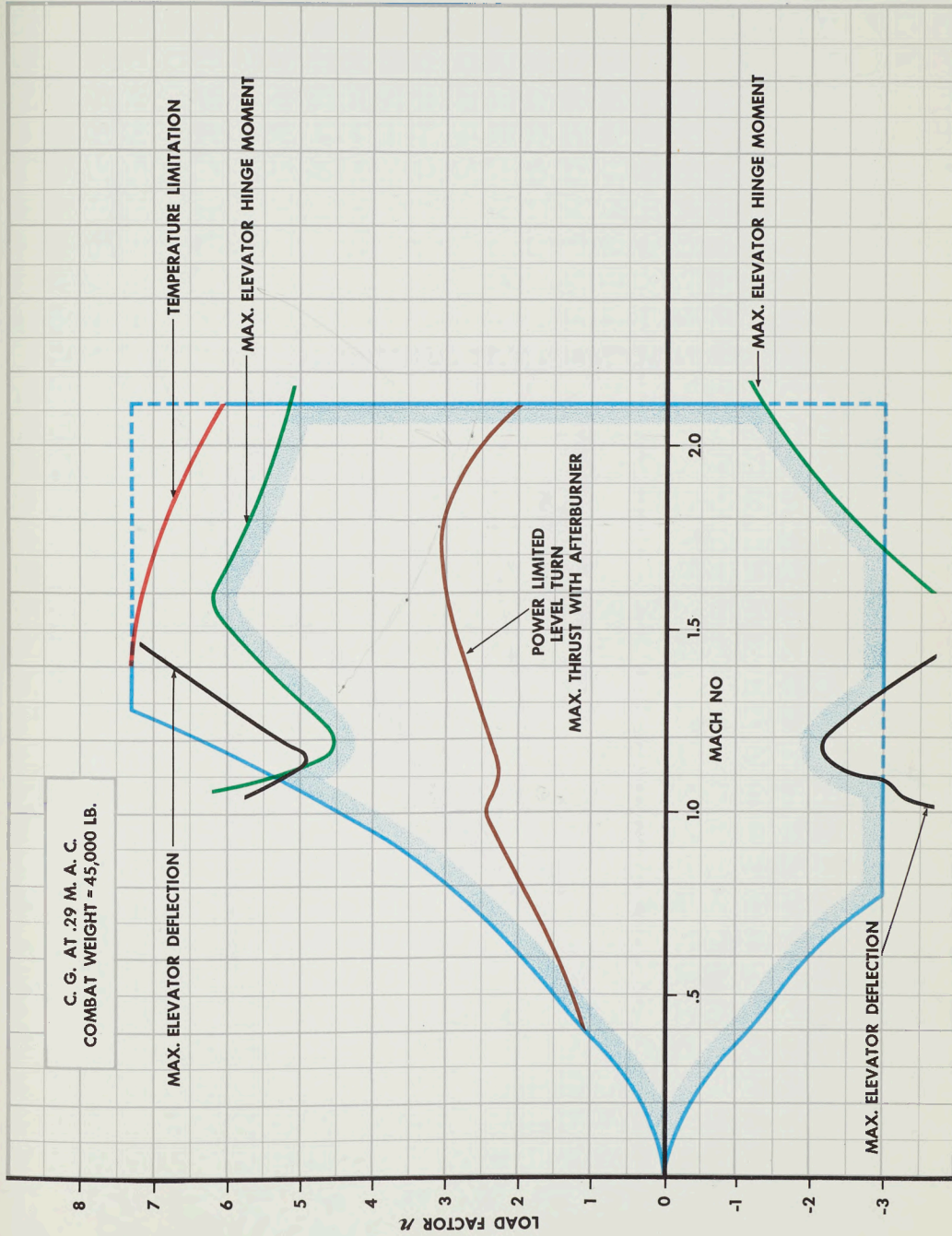
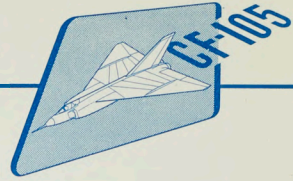
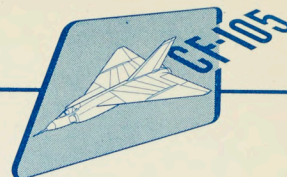

FIG. 17 PERFORMANCE FLIGHT ENVELOPE AT 40,000 FT.



3.1.3 Weights: Following is a list of the component weights of this airplane.

TABLE 8 - WEIGHT STATEMENT

Item	Weight Lb.	Percent of Gross Weight
STRUCTURE GROUP	18,366	35.97%
POWER PLANT GROUP	11,616	22.76%
FIXED EQUIPMENT GROUP	6,695	13.12%
WEIGHT EMPTY <i>43,915.83</i>	<u>36,677</u>	<u>71.85%</u>
CREW, RESIDUAL FUEL, OIL	695	1.36%
FUEL FOR 200 NAUTICAL MILES	12,620	24.72%
RADIUS HIGH SPEED MISSION		
ARMAMENT (EXPENDABLE)	<u>1,056</u>	<u>2.07%</u>
USEFUL LOAD	<u>14,371</u>	<u>28.15%</u>
NORMAL TAKE-OFF GROSS WEIGHT	51,048	100.00%

59,608.30

TABLE 9 - STRUCTURE WEIGHT

Item	Weight Lb.
WING GROUP:	9,560
Inner Wing	5,924
Outer Wing	2,948
Elevators	436
Ailerons	252
TAIL GROUP:	841
Fin	690
Rudder	151
BODY GROUP:	5,860
Front Fuselage	4,500
Rear Fuselage	1,045
Detachable Rear Fairing	315
LANDING GEAR:	2,105
Main Undercarriage	1,780
Nose Undercarriage	325
TOTAL STRUCTURE WEIGHT	<u>18,366</u> <i>19,689.22</i>

4,633

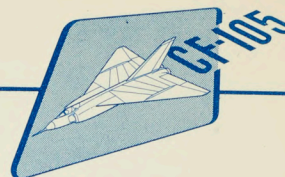

TABLE 12 - USEFUL LOAD

Item	Weight Lb.
Crew	430
Oil	40
Residual Fuel	225
Fuel for 200 Nautical Miles Radius High Speed Mission	12,620
Armament (Expendable) -- 8 Guided Missiles	1,056
<u>TOTAL USEFUL LOAD</u>	<u>14,371</u>

17,692.67
+ 3,321.67

TABLE 13 - UNIT WEIGHTS

Component	Unit Weight
Wing Group (Gross Area 1225 sq. ft.)	7.81 lb. per sq. ft.
Tail Group (Gross Area 138 sq. ft.)	6.09 lb. per sq. ft.
Weight of Fuel System (2692 Imp. Gall. of fuel)	.27 lb. per Imp. Gall.

TABLE 14 - DESIGN INFORMATION

Length - max.	73 ft.	1.65 in.
Height - max.	20 ft.	9.5 in.
Span	50 ft.	0 in.
Thickness - root chord	3.5%	
Thickness - tip chord	3.8%	
Wing area - net	766.4 sq. ft.	
Taper ratio08889	
Length - root chord	45 ft.	0 in.
Length - tip chord	4 ft.	0 in.
Maximum fuselage depth	5 ft.	10.5 in.
Maximum fuselage width	9 ft.	9 in.
Normal take-off gross weight	51,000 lb.*	
Stressing weight and load factor:		
At combat weight	45,000 lb.*	
Ultimate load factor	10.00 g.*	
Limit load factor	7.33 g.*	
Factor of safety	1.364*	

* These values are the current estimated weight and corresponding R. C. A. F. specification load factors. For structural design purposes a design gross weight of 55,000 lb. and a combat stressing weight of 47,000 lb. are actually used with corresponding load factors of 10.00 g. ultimate and 7.33 g. limit. Consequently at a stressing weight of 45,000 lb. an ultimate load factor of 10.45 g. and a factor of safety of 1.43 can be realised.

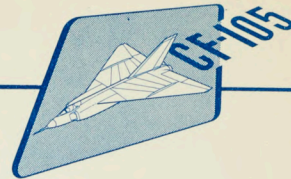

3.1.3.1 Gross weight estimations are as follows:-

Normal take-off gross weight 51,000 lb.

3.1.4 Center of Gravity:

The aircraft will be balanced with C.G. limits between 27% and 31% of the mean aerodynamic chord.

3.1.5 Areas:

Wing area, total including ailerons and elevators	1225 sq. ft.
Elevator area aft of hinge line (each)	53.39 sq. ft.
Aileron area aft of hinge line (each)	33.25 sq. ft.
Vertical tail area, total	138 sq. ft.
Fin - to rudder hinge	99.4 sq. ft.
Rudder, aft of hinge	38.6 sq. ft.
Speed brakes:	
Gross area (each)	8.85 sq. ft.

NOTE: The control surfaces are power-operated and do not incorporate aerodynamic balance aids.

3.1.6 Dimensions and General Data:

Wings:

Span, maximum	50 ft. 0 in.
Chord:	
At root	45 ft. 0 in.
At construction tip (theoretical extended section at tip)	4 ft. 0 in.
Mean aerodynamic	30 ft. 2.612 in.

Airfoil section designation and thickness

At root	NACA0003.5-6-3.7 Mod. Camber .0075 Mod.
At tip	NACA 0003.8-6-3.7 Mod. Camber .0075 Mod.

Incidence:

At root	0 deg.
At construction tip	0 deg.
Sweepback at 25% chord	55 deg. 0 min.
Anhedral	4 deg. 0 min.
Aspect ratio	2.04

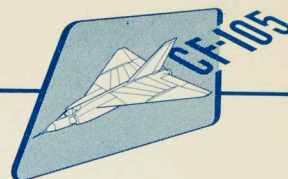

Ailerons:

Span (each)	10 ft. 0 in.
Chord (average percent wing chord)	27.2 %

Elevators:

Span (each)	10 ft. 2 in.
Chord (average percent wing chord)	18.2 %

Speed brakes (fuselage - lower)

Span (each)	2 ft. 2 in.
Chord (each)	4 ft. 1 in.

Tail - vertical:

Airfoil section designation and thickness	
At root	NACA 0003.5 -6-3.7 Mod.

At tip	NACA 0003.8 -6-3.7 Mod.
--------------	----------------------------

Sweep of leading edge	60.12 deg.
Aspect ratio	1.043

Height over highest fixed part of airplane - fin	20 ft. 9.5 in.
Height - wing tip	7 ft. 3 in.
Height to top of cockpit	14 ft. 3 in.

NOTE: The above heights are taken with the airplane in its normal ground attitude - shock absorber struts static.

Length, maximum:

Reference line level	73 ft. 1.65 in.
----------------------------	-----------------

Distance from wing m.a.c. quarter chord point to vertical tail m.a.c. quarter chord point	15 ft. 10 in.
Angle between reference line and wing zero lift line	0 deg.
Ground angle	4 deg.

Wheel rim size:

Main wheels	15 in.
Nose wheels	8 in.

Tire size:

Main wheels	29" x 7.7"
Nose wheels	18" x 5.5"

Tread of main wheels	26 ft. 6 in.
Wheel base	29 ft. 11.85 in.

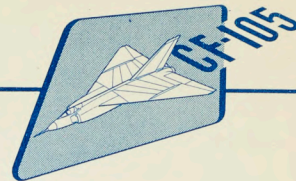

Vertical travel of axle from extended to fully compressed position:

Main wheels	12 in.
Nose wheels	10 in.

3.1.7 Control Surface and Corresponding Control Movements: Following is a table of control surface and control movements on each side of neutral position for full movement as limited by stops:-

TABLE 15

Surfaces	Control	Movement
Rudder	Surface	30 deg. RIGHT, 30 deg. LEFT
-	Pedals	According to USAF Spec. ARDCM 80-1
Ailerons	Surface	19 deg. UP 19 deg. DOWN
-	Stick	According to USAF Spec. ARDCM 80-1
Elevators	Surface	30 deg. UP 20 deg. DOWN
-	Stick	According to USAF Spec. ARDCM 80-1
Speed Brakes:	Surface	60 deg. maximum DOWN.

3.2 General:

3.2.1 General Interior Arrangement: Refer to Figs. 1 and 19. These illustrations show the disposition of crew, armament, power plant, fuel and the avionics equipment superimposed on a general arrangement drawing and a perspective drawing respectively. Additional illustrations are included in the text to show the main items of equipment in detail together with the access to same for purposes of maintenance.

These comprise:-

- Fig. 27 Structure Arrangement
- Fig. 28 Engine Installation and Removal
- Fig. 37 & 38 Armament and Electronic Equipment Installations

Special attention has been given to ease of access for those installations which require frequent servicing. This aspect is enlarged upon in the paragraphs dealing with equipment in detail.

3.2.2 Materials: These will conform to specifications approved by the RCAF.

3.2.3 Workmanship: This will conform to the usual high grade airplane practice.

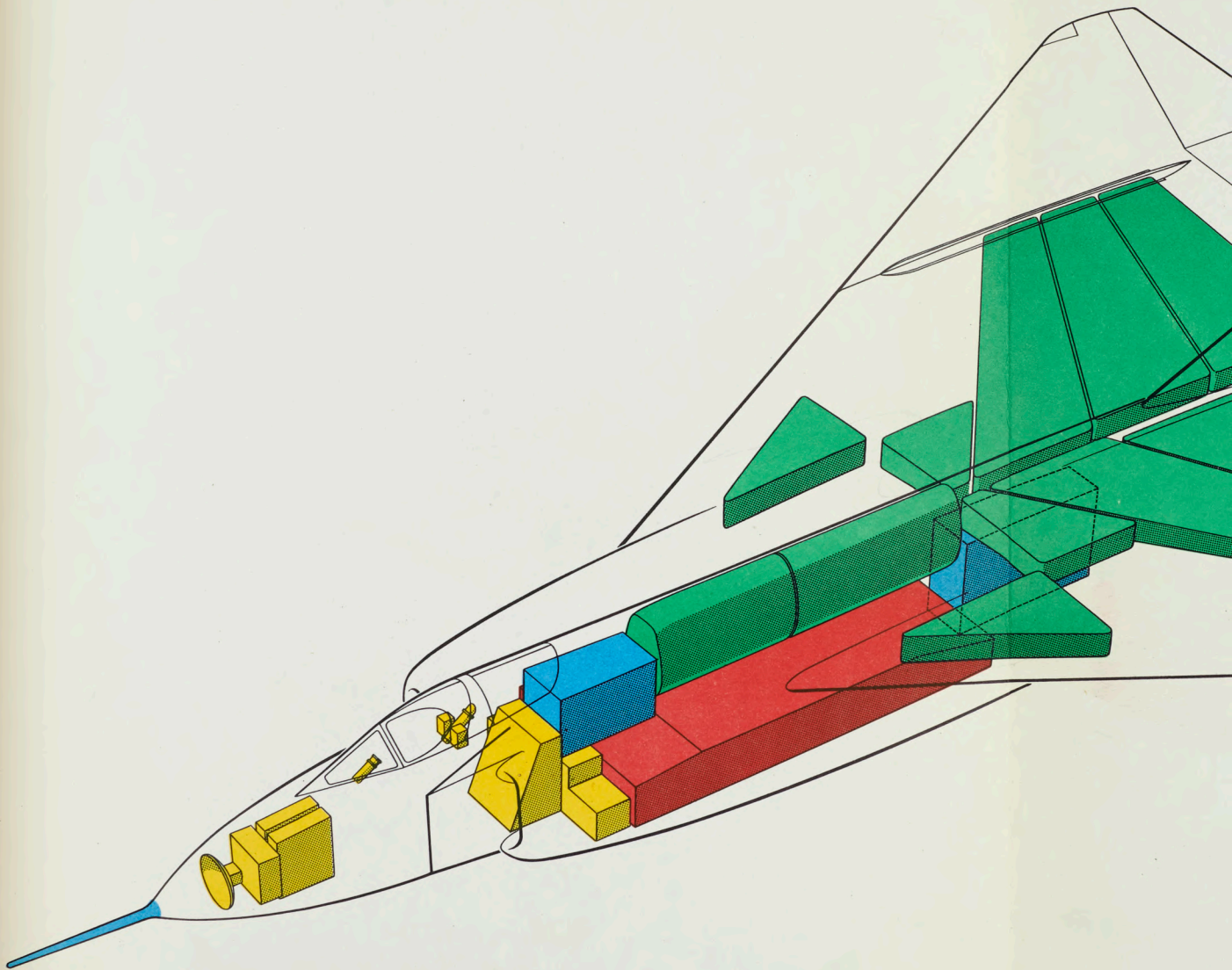

FIG. 19 EQUIPMENT ARRANGEMENT

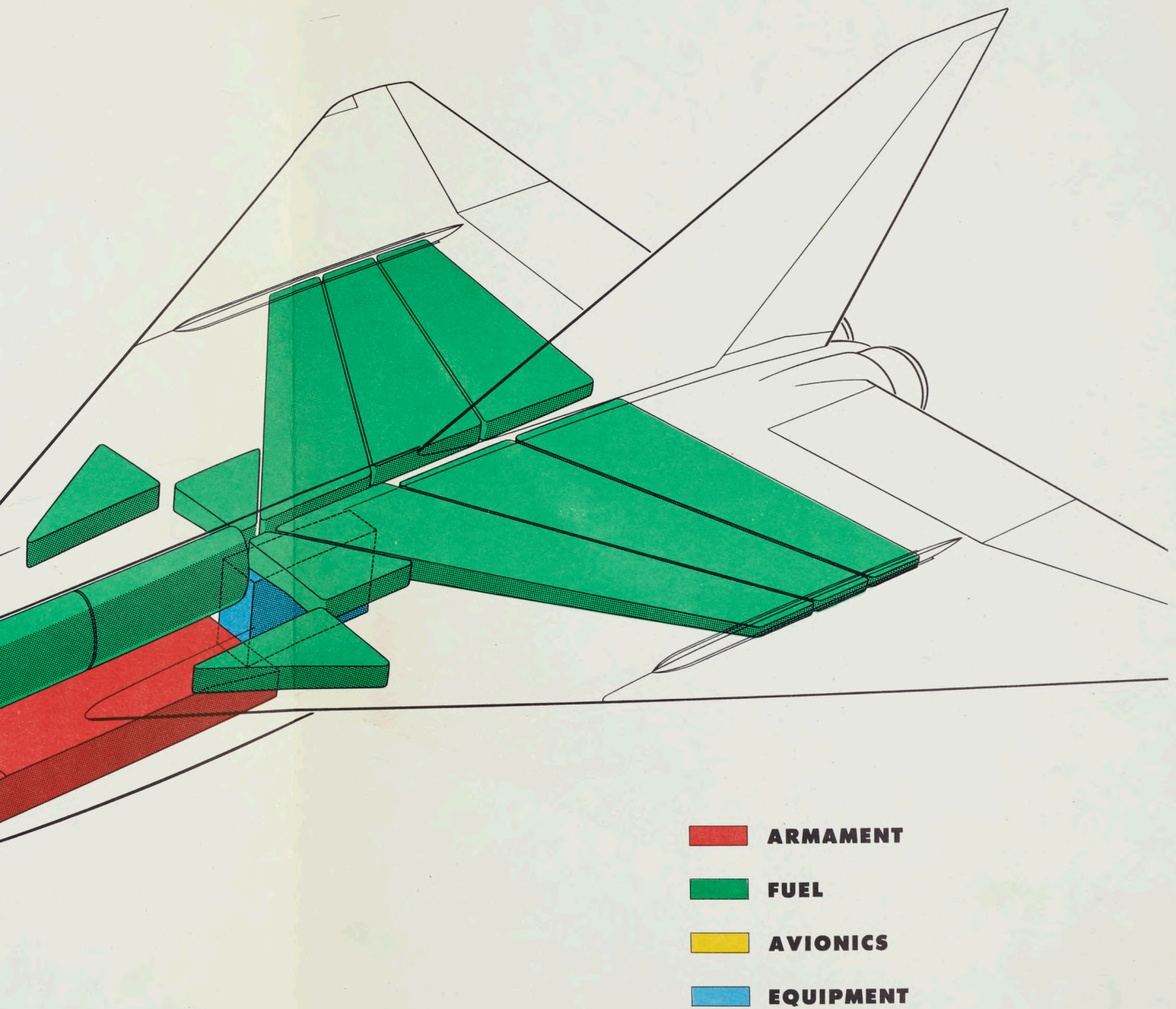

FIG. 19 EQUIPMENT ARRANGEMENT

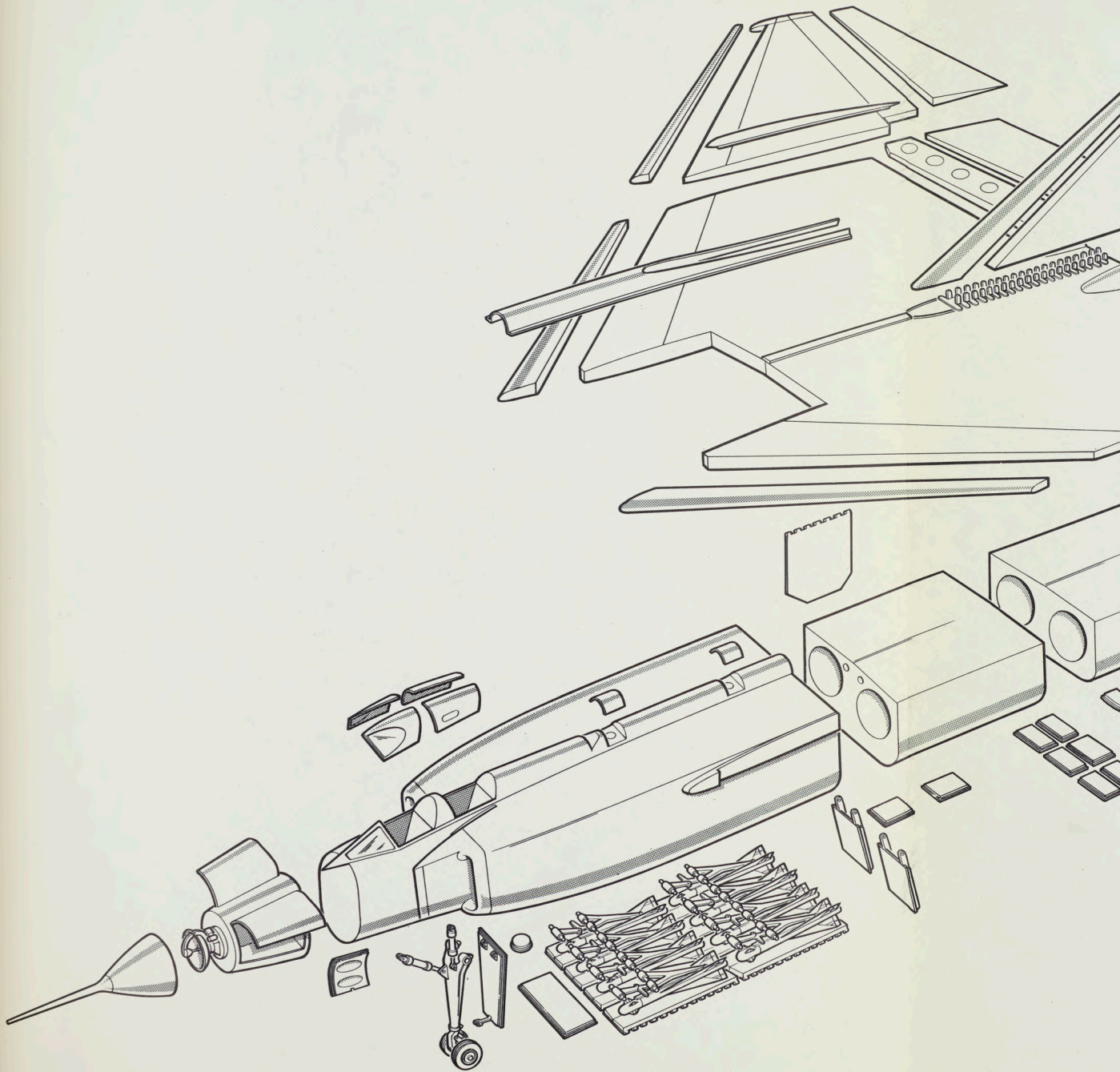
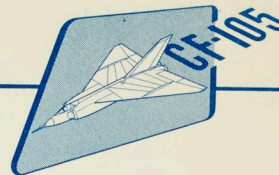

FIG. 20 CF-105 COMPONENT BREAKDOWN



3.2.4 Production, Maintenance and Repair: The design of the aircraft is such as will ensure ease of production, simple and rapid installation of the engines and equipment, and ease of general maintenance. Special attention has been given to the ease with which component parts of the structure can be inspected, maintained and repaired. The fuselage and wings are designed to facilitate the removal and replacement of damaged sections as illustrated in the component breakdown drawing Fig. 20. The fuselage is constructed in six main sections. These comprise:-

- (a) The radome and probe section.
- (b) The nose electronics section.
- (c) The front fuselage section containing the cockpit, intakes, fuselage fuel tanks, armament and equipment.
- (d) The fuselage center section containing the speed brakes and equipment.
- (e) The rear fuselage section containing the engines and after-burners.
- (f) The tail cone section.

Item (c) forms the largest fuselage section and is approximately 30.5 feet long by 9.75 feet wide by 7.2 feet deep. The wing structure, which is continuous across the fuselage, is divided into ten separate parts. These comprise:-

- (a) Left and right inner wings joined at the fuselage center line
- (b) Left and right inner wing trailing edges
- (c) Left and right inner wing leading edges
- (d) Left and right outer wings
- (e) Left and right outer wing leading edges

The elevators and ailerons are separately hinged to the trailing edge assemblies of the inner wings and outer wings respectively. The dimensions of the largest wing panel are approximately 14 feet by 31.5 feet.

NOTE: These dimensions will allow transport by road or rail.

Bolted joints connect the fin to the wing structure. This application also applies to the attachment of the main and nose undercarriage units.

3.2.5 Interchangeability and Replaceability: Effective on the first prototype air-

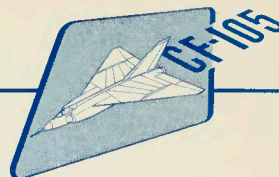

plane, the component parts of all airplanes of the same model will be interchangeable or replaceable in accordance with and to the extent required by the RCAF.

3.2.6 Finish: The finish of the airplane and parts will be in accordance with RCAF requirements as stipulated in CAP 479.

3.2.7 Identification and Marking: The airplane and its components will be identified and otherwise marked in accordance with RCAF requirements.

3.2.8 Extreme Temperature Operation: The airplane as a whole, including equipment, will be so constructed that it will function satisfactorily in any or all temperature conditions that will be encountered. A ground temperature range of:-

-65 degrees Fahrenheit
to
+160 degrees Fahrenheit

has been established as the range in which the airplane will operate.

3.2.9 Climatic Requirements: The airplane and its equipment will not be adversely affected by other climatic conditions incident to the temperature range stated in the preceding sub-paragraph, and will be capable of transfer from one climate to another without penalty of extensive modification and adjustment.

3.2.10 Lubrication: Lubrication of the airplane will conform to the requirements of the RCAF.

3.2.11 Standard Parts: Standard parts used in the construction of the airplane and contractor furnished equipment as incorporated in the various systems installed in the airplane will conform to RCAF requirements as laid down in CAP 479.

3.2.12 Crew: The crew will consist of the following:-

One (1) Pilot and
One (1) Airborne interception radar operator

3.2.13 Equipment Installations: Equipment to be carried in the airplane is listed below.

3.2.13.1 Armament:

Guided missiles (Hughes 'Falcon') 8 off
or
Guided missiles (Douglas 'Sparrow 2') 3 off

Further information on this equipment is contained in paragraph 3.18.

3.2.13.2 Communications and Navigation Equipment: This consists of the Hughes

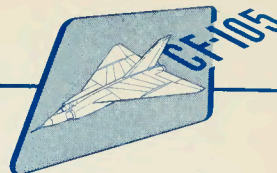

MX.1179 integrated navigation - communication - interception system, operating details of which are described in the following sub-paragraphs. It is anticipated that this digital computing MX.1179 system will not be available for fitment to early CF-105 aircraft, and, as an interim measure, the two-man analog computing MG-3 system will be fitted. The MG-3 system has not the capacity for memory storage and consequent automatic operation which is one of the features of the MX.1179 system, but it is the most advanced system likely to be available for fitment to early CF-105 airplanes.

3.2.13.2.1 Operation: Due to the high speed of the airplane, it is considered essential to fit automatic interception and navigation equipment to the type specified in the preceding sub-paragraph. An additional function of the equipment is armament fire control. Details of this latter procedure are outlined in paragraph 3.17.

3.2.13.2.2 Interception navigation is effected by referring the G.C.I. broadcast data to the airplane position as determined by an A.P.I., corrected for wind by the use of DME omni range. All of the foregoing data are fed, as pulses, through a single, high speed digital computer which, through magnetically stored instructions processes all the relevant information, and sends the appropriate instructions to the auto-pilot which controls the flight path. A gyro-stabilized platform, which gives a vertical and north reference, is used as a datum for the steering instructions.

3.2.13.2.3 After the interception has been completed automatically, the computer gives the necessary instructions to reach a marshalling area defined by its coordinates in the memory of the computer. From this area, the airplane is directed to the landing slot by a signal sent by the ground controller. This can be relayed either through the pilot or by automatic means. Landing will be accomplished by AILS or AGCA, the choice being dependent on which system is first developed to a high state of perfection.

NOTE: It is assumed that the AILS will meet this criterion but will be displaced, ultimately, by a superior AGCA system.

3.2.13.2.4 Several redundancies occur in the navigation system. These will permit it to function with reasonable efficiency in the event of a number of contingencies. If the ground data link is severed, the wind vector computed from the last DME omni range information is retained in the memory of the computer and applied, from the severage point onwards, to the API without change. The error involved by this method is often quite small. The path of the target may also be computed from GCI data stored magnetically in the event of failure of this link: reasonable accuracy is ensured providing that no evasive measures are attempted by the target. ADF is also used as an auxiliary source of information and may be compared with the data secured from the other sources to check their veracity. Alternatively, it may be used in the event of their failure.

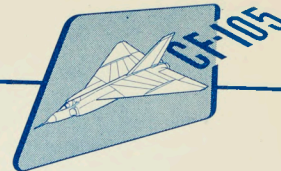

3.2.13.2.5 All navigational information is displayed to the pilot in a convenient form so that he may take over any part of the system which becomes unserviceable. Enemy interference with the ground data link can be avoided if the pilot changes the wave length. A range of approximately twenty frequencies is provided for this purpose. Any other remedial action, which could be taken by the pilot of a conventional airplane, can also be applied by the pilot of this airplane during an emergency. For this purpose a manual over-ride of all controls is provided, guidance being obtained from the information displayed to the pilot from various sources.

3.2.13.2.6 Under normal circumstances, the only flight functions expected from the pilot are:-

- (a) Taxiing
- (b) Take-off until terrain clearance has been secured, and
- (c) Stopping the engines after taxiing to the ramp.

Landing is accomplished automatically.

3.2.14 Equipment and Furnishings: Following is a list of equipment and furnishings provided in the airplane:-

Item	Reference Para.
Two turbo-jet engines and afterburners ...	3.12
Instruments	3.14
Hydraulic and pneumatic equipment	3.15
Electrical equipment	3.16
Electronic equipment	3.17
Armament	3.18
Furnishings	3.19
Air conditioning and anti-icing equipment	3.20
Auxiliary gear	3.22

3.3 Aerodynamics:

3.3.1 General: As the mission of this airplane requires the use of supersonic speeds, the basic configuration is so designed as to achieve the best possible aerodynamic characteristics in transonic and supersonic flight. This condition can be obtained by using the maximum wing sweep and the minimum t/c. Detailed studies have shown that, with conventional planforms, it is practically impossible to find accommodation in a wing of less than 6% t/c for the necessary equipment. In addition to this, the weight of the wing structure becomes excessive. Utilizing a delta configuration, however, a 3.5% t/c wing is perfectly practical with a 60 degrees sweep at the leading edge. Furthermore, due to the favourable disposition of material, the weight per square foot does not exceed that of a conventional unswept wing. These considerations made the selection of the delta planform a mandatory

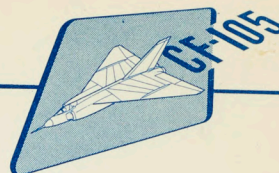

requirement. Turning to the tail unit, it has been found that, with the delta configuration, a horizontal tail becomes not only a superfluity but also an embarrassment. The reasons are as follows:-

- (a) If a tail is raised substantially above the wing chord line it becomes destabilizing at moderate angles of incidence, thus giving rise to longitudinal instability. This, apart from being dangerous, restricts the airplane's manoeuvrability seriously.
- (b) If the tail is near the chord plane, these difficulties are overcome but it becomes impossible to secure the necessary ground angle for the low aspect ratio wing. The wake from the wing is also a serious problem in this case.

Accordingly then, the supersonic airplane is made tail-less. Troubles with longitudinal damping which have been associated with this configuration are avoided by using at least 60 degrees sweep.

3.3.1.1 Subsonic Profile Drag Synthesis: The drag used in the subsonic performance estimates was synthesized by adding up the drags for the various parts including appropriate allowances for roughness and interference. From the result, the drag coefficient of the wetted area (or, to use the technical appellation 'aerodynamic cleanness') was computed. As a further criterion, the ratio of the total drag to the flat plate friction drag was also calculated. This is known as the 'cleanness ratio'. These two quantities were compared with the values achieved by several airplanes in service; the comparison forms a check on the validity of the original estimate. Following are details of the synthesis:-

Note: The figures in parentheses in the following text refer to the list of references in sub-paragraph 3.3.1.5.1.

Body - including canopy and side inlets: Due to the jet location in the tail, the diameter-length ratio of the fuselage (\bar{d}/l) is effectively reduced by approximately 40%. Then, based on the wetted area, the drag for a streamline body, with transition at the nose for cruise flight conditions, is found (1 & 2). An additional drag increment of 25% is added for roughness and leakage. The drag is then referred to the gross wing area.

Wing: It has been shown that subsonic drag is independent of the angle of sweep-back (3 & 4) providing that the drag is based on the streamwise thickness chord (t/c) and thickness distribution. On this basis, the exposed wing drag is determined (1). An additional drag increment, due to flush rivets, is taken as .001 (5 & 6). The wing drag is then referred to the gross wing area.

Vertical Tail: Data for the vertical tail drag is found in the same way as that for the wing drag.

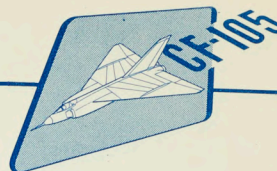

Interference: The drag of wing + interference has been found from rocket model tests (7) on models similar in configuration, differences occurring primarily in body cross-section area to wing gross area ratio. These, however, bracket the ratio required so that a reasonable estimate of the interference can be obtained.

Miscellaneous: The 25% drag increment already added to the body and the allowance for rivets on the wing and tail are only for normal conditions. It is thought that the armament section doors and the air conditioning system will give rise to more drag.

The component drags stated are enumerated below together with their percentage of the total zero lift drag.

Part	C_{D_0}	% Total
Wing	.00389	44.8
Body - including canopy and side air intakes	.00306	35.1
Vertical tail	.00081	9.3
Armament	.00015	1.7
Interference	.00079	9.1
TOTAL:	.0087	100.0

The aerodynamic cleanness and cleanness ratio of several jet airplanes - including the CF-105 - are given in the following list as a check on the low speed profile drag estimate. It should be noted that the smooth flat plate friction drag used to obtain the cleanness ratio is varied in accordance with the averaged Reynolds number of each airplane.

<u>Airplane</u>	<u>Aerodynamic Cleanness</u>	<u>Cleanness Ratio</u>
CF-100	.00367	1.50
F80	.00299	1.20
F86	.00326	1.30
Meteor 4	.00380	1.52
CF-105	.00311	1.41

The aerodynamic cleanness required for the CF-105 is relatively quite good. This is not as difficult to attain as for the other airplanes due to the much higher Reynolds numbers of the components. The true situation is more clearly illustrated by the cleanness ratio, where this is allowed for; here the CF-105 lies approximately half way between the F86 and the CF-100. While the F80 sets a very high standard of surface finish, the F86 is not, by comparison, remarkable in this respect.

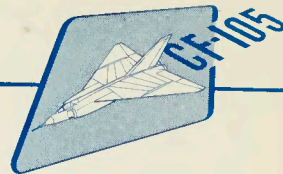

Accordingly, it is felt that a small improvement over the CF-100 is quite practical and does not represent any undue optimism as to what may be achieved by a certain amount of attention to surface finish.

3.3.1.2 Supersonic Profile Drag Synthesis: (Refer to Fig. 21) The supersonic drag estimation was based on available experimental data and theoretical calculations, from which a detailed analysis, much as in the subsonic case, was evolved. CF-105 wind tunnel results are not given due to the difficulty in correcting profile drag for a ducted model configuration. However, on the basis of present corrections there appears to be good agreement with the estimates.

Fuselage: The fuselage drag was estimated on the basis of a parabolic body of equal frontal area. That this approximation is reasonable for ducted bodies having near unity mass flow through their intakes is shown in Refs. 8 and 9. (When the flow is less than unity, the increase in drag is handled through the spillage drag term, see paragraph 3.3.1.5). For the equivalent parabolic body, the maximum cross-sectional area was assumed at mid-length and the fineness ratio taken equal to 8. From Refs. 7, 10, 11, the drag coefficients of similar bodies based on their frontal area were determined and from these the CF-105 body drag coefficient was estimated. Base drag was subtracted due to the effective elimination of the base by the jet stream; and a further correction was applied to take into account the ratio of base area to maximum frontal area.

The fuselage wave drag was also calculated theoretically using refs. 12 and 13. Adding the wave drag to the estimated skin friction drag (14) gives good agreement with the value based on experimental data.

Canopy: The drag of the canopy was estimated from data on 'V' -shaped and normal-front canopies on Free Flight Models (15 & 16) and then corrected for Fineness Ratio (taking into account the dorsal fairing which extends back to the vertical fin).

Wing: Available wind-tunnel data (7) brackets the CF-105 maximum body cross-sectional area to gross wing area ratio almost exactly and from this an estimate of wing plus interference drag was made. The model with the larger frontal to wing area experienced a drag rise over the subsonic value and the model with the smaller ratio, a drag decrease. The CF-105 ratio being midway, it could then be assumed to have a constant drag.

However, on the basis of theoretical calculations(17) and Free Flight Tests (18), the supersonic wing plus interference drag was increased 38% over the subsonic value for a wing of the CF-105 thickness to chord ratio, sweepback and aspect ratio. The estimate is therefore felt to be quite conservative.

Vertical Tail: Being of the same thickness and sweepback, the fin was treated in the same manner as the wing.

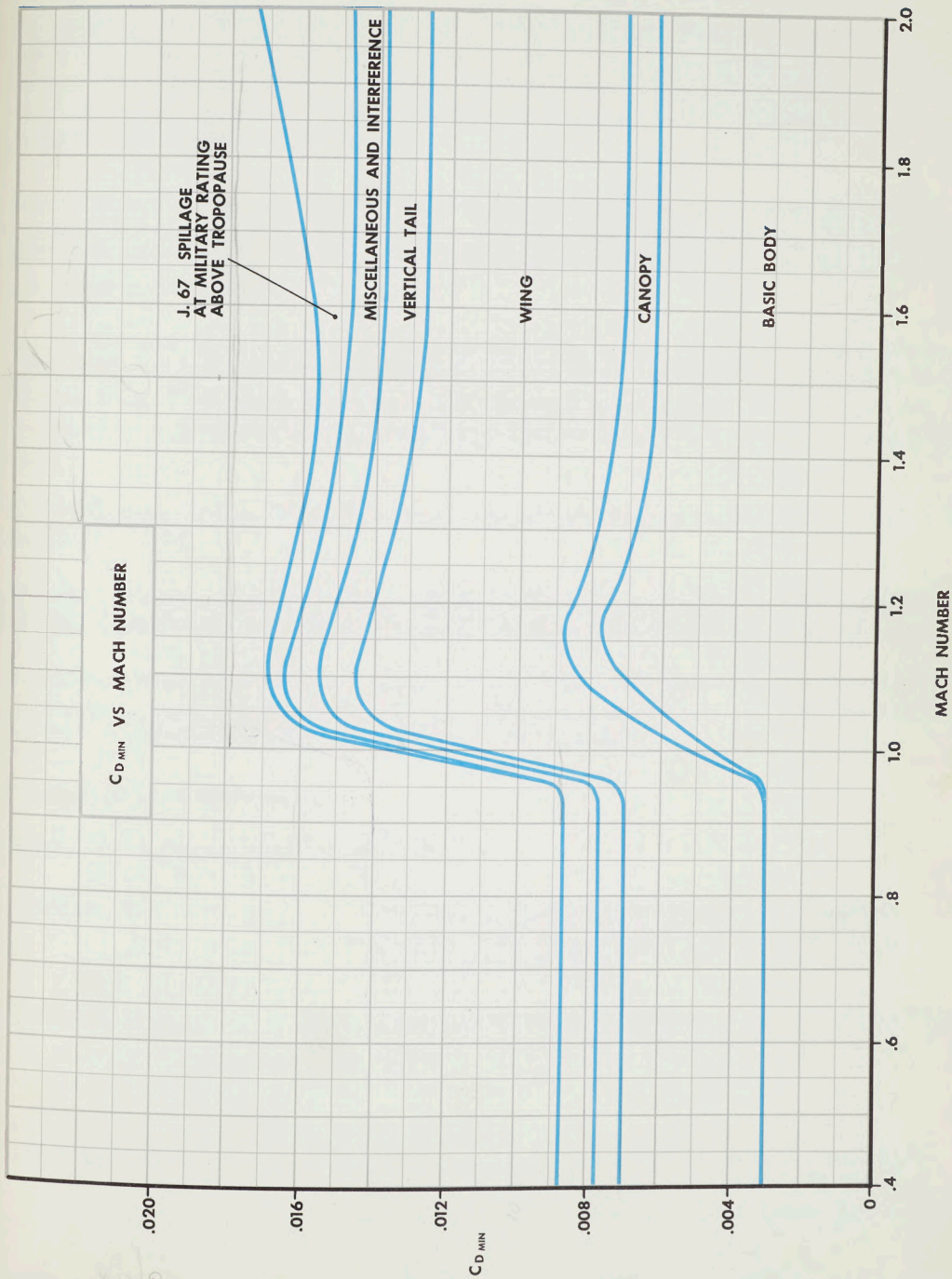
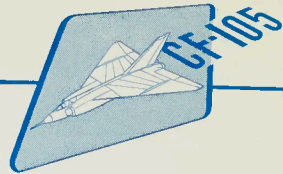
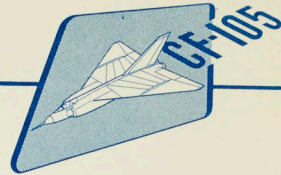

FIG. 21 PROFILE DRAG COEFFICIENT



Miscellaneous: From Reference 19, it may be seen that a fair degree of waviness and pitting has a negligible effect on the supersonic drag. The interference of the wing and fin is already covered in their respective sections. This extra drag then provides for rivets (20), armament doors, leakage and air conditioning system effects.

3.3.1.3 Drag Efficiency: By means of tests on a .03 scale model of the CF-105 in the Cornell Transonic Wind Tunnel (21), the drag efficiency "e" (Fig. 22) was determined up to Mach 1.23. References 22-25 were used to extrapolate the curve to higher supersonic speeds.

3.3.1.4 Elevator Drag: Again by means of Wind Tunnel Tests on a scale model, the effect of elevator deflection on the minimum drag C_{DMIN}/δ^2 (Fig. 23) and the lift minimum drag C_{LCDMIN} (Fig. 24) were obtained up to a Mach number of 1.23. References 26 - 28 were used to determine the elevator effect at higher Mach Numbers.

3.3.1.5 Spillage Drag: This has been calculated using an estimate based on References 29 and 30.

Due to the presence of a mass flow bypass, the spillage drag has been reduced to a relatively small value except at very high Mach Numbers and low engine r. p. m.

The spillage drag correction is applied as a decrease in engine thrust rather than an increase in drag as shown in Fig. 21, since it arises from and depends on the mass flow which varies with altitude below the tropopause.

3.3.1.5.1 List of References:

1. Royal Aeronautical Society Data Sheets.
2. Meleus, H. "Results of Drag Measurements of Fuselage Models in the High-Speed Tunnel of the DVL" MAP/VG R & T 857.
3. Maskell, E. C. "High Speed Tunnel Tests on a Series of 14% Thick Wings of Varying Sweepback and Taper Ratio." RAE Aero 2295.
4. Whitcomb, R. T. "An Investigation of the Effects of Sweep on the Characteristics of a High Aspect Ratio Wing in the Langley 8-Foot High-Speed Tunnel" NACA RM L6J01a.
5. Young, Serry and Morris "Flight Tests on the Effect of Surface Finish on Wing Drag" ARC R & M No. 2258.

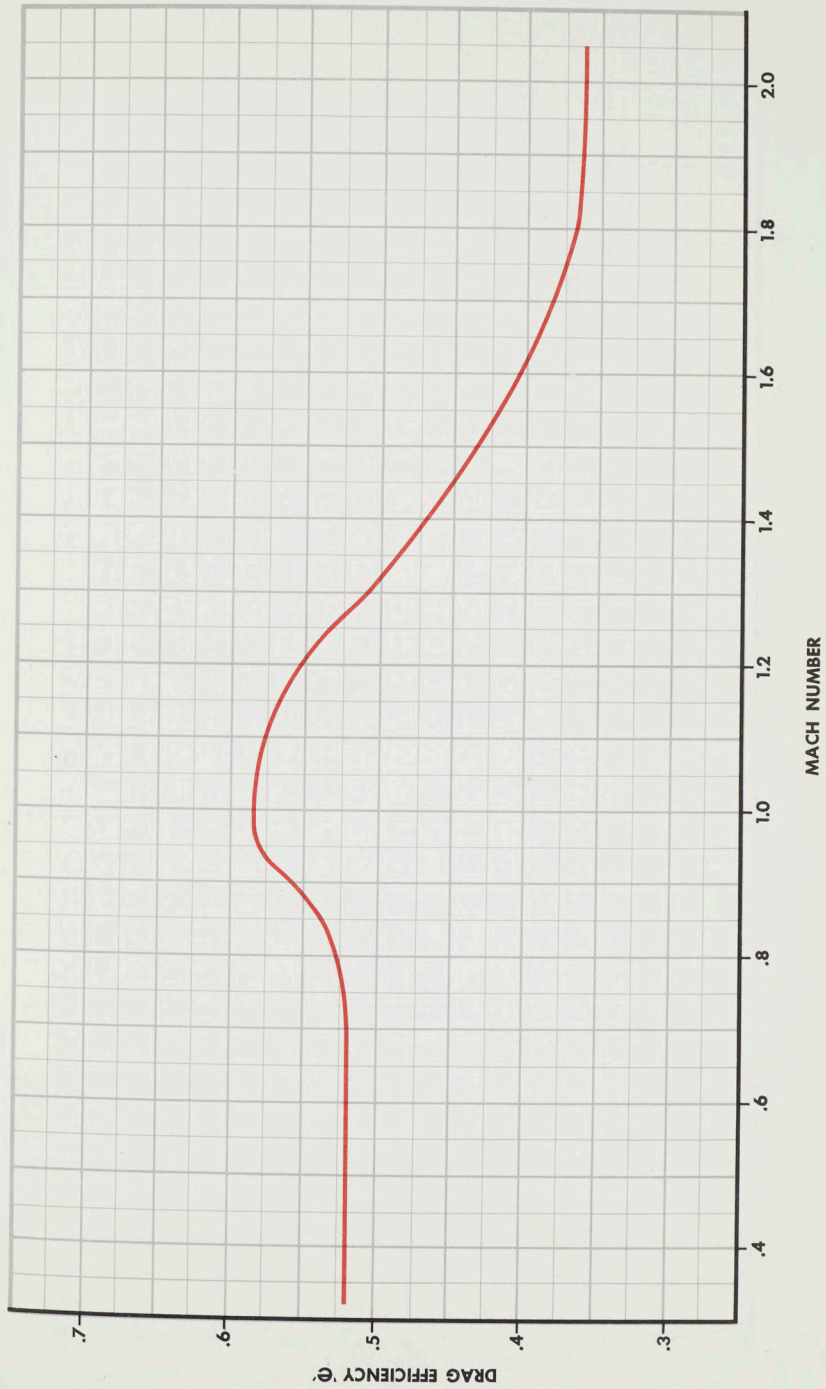
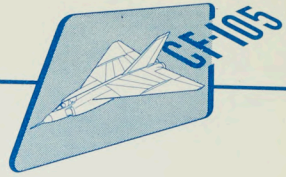

FIG. 22 DRAG EFFICIENCY

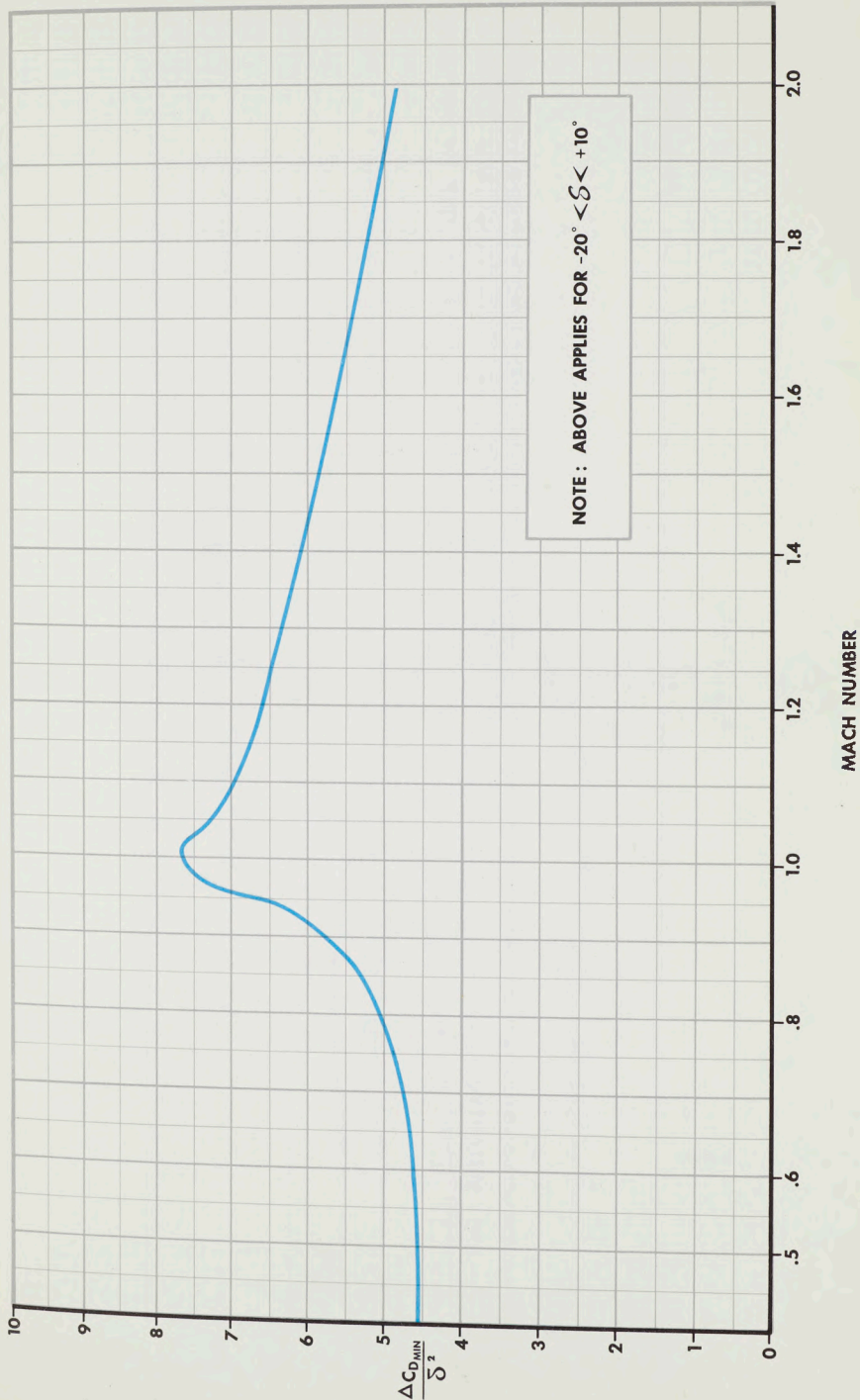
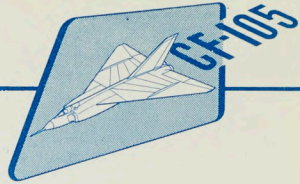

FIG. 23 EFFECT OF ELEVATOR DEFLECTION ON MINIMUM DRAG COEFFICIENT

SECRET

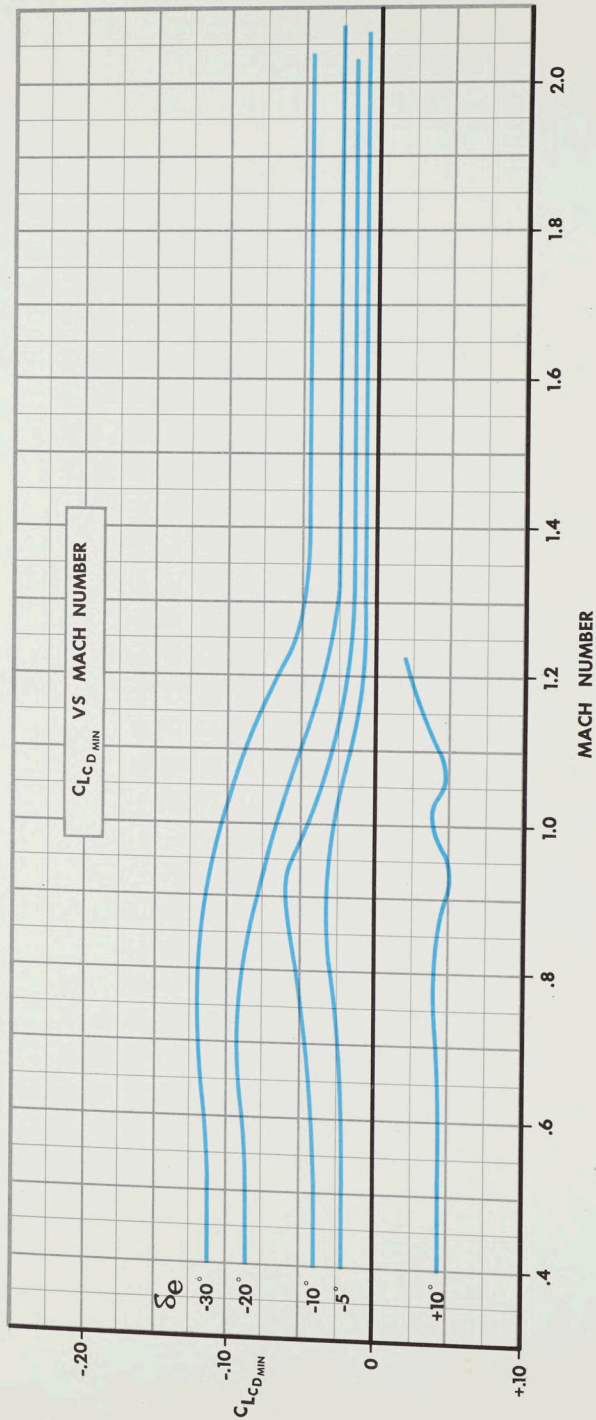
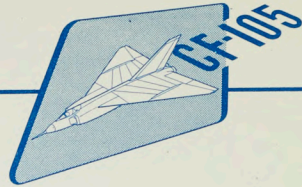
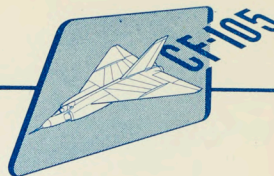
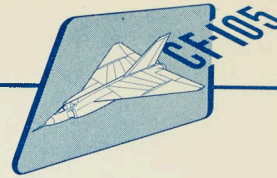

FIG. 24 LIFT AT MINIMUM DRAG

SECRET



6. Day and Schwarzbach "A Flight Investigation of the Effects of Surface Finish on Wing Profile Drag" Jour. of Aero. Sciences, April, 1946.
7. Schult, E.D. "Comparison of Large-Scale Flight Measurements of Zero-Lift Drag at Mach Numbers from 0.9 to 1.7 of Two Wing-Body Combinations having similar 60° Triangular Wings with N.A.C.A. 65A003 Sections" N.A.C.A. RM L50I22.
8. Pierpont and Braden "Investigation at Transonic Speeds of a Forward-Located Underslung Air Inlet on a Body of Revolution" N.A.C.A. RM L52K17.
9. Nichols and Pendley "Performance of Air Inlets at Transonic and Low Supersonic Speeds" N.A.C.A. RM L52A07.
10. Hart and Katz "Flight Investigations at High-Subsonic, Transonic and Supersonic Speeds to Determine Zero-Lift Drag of Fin-Stabilized Bodies of Revolution having Finess Ratios of 12.5, 8.91 and 6.04 and Varying Positions of Maximum Diameter" N.A.C.A. RM L9I30.
11. Carlson, H.W. "Preliminary Investigation of the Effects of Body Contouring as Specified by the Transonic Area Rule on the Aerodynamic Characteristics of a Delta Wing-Body Combination at Mach Numbers of 1.41 and 2.01" N.A.C.A. RM L53G03.
12. Theoretical Forebody Wave Drag R.A.E. Tech. Note Aero 1934.
13. Theoretical Afterbody Wave Drag R.A.E. Report Aero 2348.
14. Johnson, J.E. "Skin Friction at Supersonic Speeds" R.A.E. TM Aero 130.
15. Alexander, S.R. "Effect of Windshield Shape of a Pilot's Canopy on the Drag of an N.A.C.A. RM-2 Drag Research Model in Flight at Transonic Speeds" N.A.C.A. RM L8E04.
16. Purser, P.E. "Effect of a Pilot's Canopy on the Drag of an N.A.C.A. RM-2 Drag Research Model in Flight at Transonic and Supersonic Speeds" N.A.C.A. RM L7I22.



17. Warren, C.H. "The Estimation of the Drag of an Aircraft at Supersonic Speeds" R.A.E. TM Aero 132.
18. Lawrence, T. "Estimation of Swept Wing Drag at Supersonic Speeds - A Preliminary Survey" R.A.E. TN Aero 2223.
19. Jackson, H.H. "Flight Measurements of the Effects of Surface Condition on the Supersonic Drag of Fin-Stabilized Parabolic Bodies of Revolution" N.A.C.A. RM L52B26.
20. Hopko, R.N. "Preliminary Free-Flight Investigation of the Effects of Rivets and Lap Joints on the Drag of Bodies at Zero Lift at Supersonic Mach Numbers to 2.1" N.A.C.A. RM L52F09.
21. Transonic Wind Tunnel Tests of a .03 Scale Model of the A.V. Roe C-105 Aircraft in the Cornell Aeronautical Laboratory, Inc. 4 Foot Transonic Wind Tunnel - Report No. AA-891-W-1.
22. Heitmeyer and Smith "Lift, Drag and Pitching Moment of Low-Aspect-Ratio Wings at Subsonic and Supersonic Speeds - Plane Triangular Wing of Aspect Ratio 2 with N.A.C.A. 0003-63 Section" N.A.C.A. RM A50K24a.
23. Smith and Heitmeyer "Lift, Drag and Pitching Moment of Low-Aspect-Ratio Wings at Subsonic and Supersonic Speeds - Plane Triangular Wing of Aspect Ratio 2 with N.A.C.A. 0005-63 Section" N.A.C.A. RM A50K21.
24. Smith and Heitmeyer "Lift, Drag and Pitching Moment of Low-Aspect-Ratio Wings at Subsonic and Supersonic Speeds - Plane Triangular Wing of Aspect Ratio 2 with N.A.C.A. 0008-63 Section" N.A.C.A. RM A50K20.
25. Hall and Heitmeyer "Lift, Drag and Pitching Moment of Low-Aspect-Ratio Wings at Subsonic and Supersonic Speeds - Twisted and Cambered Triangular Wing of Aspect Ratio 2 with N.A.C.A. 0003-63 Thickness Distribution" N.A.C.A. RM A51E01.

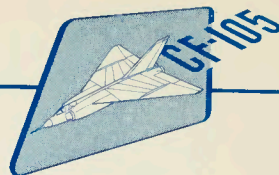

26. Boyd and Pfyl "Experimental Investigation of Aerodynamically Balanced Trailing-Edge Control Surfaces on an Aspect Ratio 2 Triangular Wing at Subsonic and Supersonic Speeds" N. A. C. A. RM A52L04.
27. Boyd, J. W. "Aerodynamic Characteristics of Two-25%-Area Trailing-Edge Flaps on an Aspect Ratio 2 Wing at Subsonic and Supersonic Speeds" N. A. C. A. RM A52D01c.
28. Mitcham, Crabill & Stevens "Flight Determination of the Drag and Longitudinal Stability and Control Characteristics of a Rocket-Powered Model of a 60° Delta-Wing Airplane from Mach Numbers of 0.75 to 1.70" N. A. C. A. RM L51I04.
29. Fraenkel "The External Drag of Some Pitot-Type Intakes at Supersonic Speeds - Part I" R. A. E. Report Aero 2380.
30. Klein "The Calculation of Scoop Drag for a General Configuration in a Supersonic Stream" Douglas SM 13744.

3.3.1.6 Intake System: In order to increase total pressure recovery at high Mach Numbers, a 12°, two-dimensional compression ramp has been used.

A diverter-type boundary layer bleed of generous dimensions, which also houses the air-conditioning intake, has been installed to increase total pressure recovery at all Mach Numbers.

The D-shaped intake with slightly rounded lips diffuses into a circular duct of sufficient size to keep the Mach Number below 0.5 under all conditions. Intake lips designed for high critical Mach Numbers have been employed to ensure satisfactory operation at both Sea Level static and Supersonic cruising conditions.

A mass flow bypass situated just ahead of the engine is used at Mach Numbers above 1.5 in order to prevent instability of the shock system and also serves to decrease the spillage drag.

3.3.2 Stability and Control:

3.3.2.1 Longitudinal Stability and Control: The airplane will have positive static longitudinal stability for all speeds, loadings and power conditions. A push will be required to increase, and a pull to decrease the speed for all conditions except when the Mach number is between 1.05 and 1.15 up to 40,000 ft. and .90 to 1.10 for altitude over 40,000 ft. The static margin (measure of static stability) increases

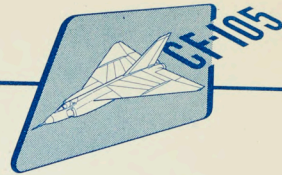

steadily with Mach number until it is approximately four times the low speed value at supersonic speeds.

3.3.2.1.1 Dynamic Longitudinal Stability: At all speeds and altitudes short period pitching oscillations will be damped. Long period (phugoid) oscillations will be damped by an electronic damper which is included as part of the auto-pilot.

3.3.2.1.2 Longitudinal control is achieved by plain flap-type elevators which are power operated and fully irreversible. Aerodynamic balancing aids are not fitted to the surfaces. The effectiveness of the controls at:-

- (a) Sea level is shown in Fig. 16
- (b) 40,000 feet is shown in Fig. 17
- (c) 50,000 feet is shown in Fig. 18

It will be seen from the graphs that nearly all potential manoeuvrability - as limited by the maximum lift coefficient obtainable at a given Mach number - is realized by the elevators at a cost of 60,000 ft. lb. hinge moment required at each side.

3.3.2.1.3 Take-off: It has been established that the main parameters involved in take-off characteristics from the control point of view are:-

- (a) The main landing gear position in relation to the c.g., and
- (b) The angle between the wing chord and the ground line (airplane attitude - nose wheel on the ground).

Suitable choice of these parameters has allowed the speed required to raise the nose to equal 90% of the take-off speed and has reduced to a minimum the stick movement required between the nose-up and take-off positions to trim in the air near ground level (equivalent to approximately 5 degrees elevator movement). In consequence, the undesirable aspects of 'stick pumping' at take-off and 'jumping off' the runway have been avoided. These are noticeable characteristics of some contemporary delta wing airplanes. For the CF-105, however, a take-off technique similar to orthodox high-speed fighters is envisaged differing only in the rather large ground angle involved. Take-off speed is approximately 137 knots at a forward c.g. of 27% m.a.c.

3.3.2.1.4 Landing: Landing will be accomplished at small incidences using the flying-in technique. A tail parachute, streamed either automatically or by manual control, will be used to achieve braking in order to keep the landing run within reasonable limits. Speed brakes are also used.

3.3.2.1.5 Bailed Landing: Stability difficulties will not arise as long as the speed is not allowed to fall below 140 knots. At speeds below 140 knots with full power on the airplane will have negative static longitudinal stability similar to that occurring on most conventional airplanes.

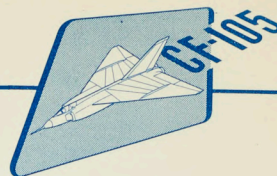

3.3.2.2 Center of Gravity Limits: Considerable difficulty arises, for an airplane operating through a large Mach number range, in fixing c.g. limits from a longitudinal stability point of view. This difficulty is created by the following:-

- (a) The extensive aft travel of the aerodynamic center with Mach numbers, and
- (b) A forward travel with an increasing lift coefficient for moderate speeds (up to $M = .7$).

Aggravation of the situation is caused by the destabilizing effects of power at high lift coefficients. In normal practice, it is customary - with orthodox subsonic airplanes - to provide for a static margin of approximately 5% m.a.c. at low speeds and high lift coefficient. To achieve a similar provision with supersonic airplanes it would mean, in the case of the CF-105, an increase of its supersonic static margin by 40%. At high altitudes and speeds (because of the low value of aerodynamic damping), elevator effectiveness in executing pull-outs and turns is almost directly proportionate to the static margin. In effect, this means that the penalties at high speeds and altitudes - which are the operational requirements for this airplane - would be either a 40% reduction in pull-out and turning performance or an even higher percentage increase in hinge moments required to maintain the performance specified in the flight envelope graphs. (Figs. 16 - 18). Additionally, it would mean a higher overall drag due to higher elevator deflection and consequent greater loss of height in high 'g' turns. The whole performance, therefore, as an efficient interceptor airplane, would be affected. It would appear then, that to aim at the traditional low speed static margin is an unacceptable solution when dealing with supersonic airplanes. Consequently the aft c.g. limit on this airplane is fixed at 31% m.a.c. which gives:-

- (a) A static margin of 4% at low speeds for a C_L range of 0 to .3, and
- (b) A static margin of 2% at low speeds for a C_L range of .3 to 1.1.

In the following table data are given on static margins at low speeds of other delta airplanes to indicate that other designers have reached similar conclusions.

TABLE 16 - COMPARISON OF NEUTRAL POINT, AFT C.G. AND STATIC MARGIN FOR DELTA WING AIRPLANES

Aircraft	Neutral Point	Aft C.G. Limit	Static Margin $0 < C_L < .3$	Static Margin $.3 < C_L < .7$ (estimated)
Avro 707B	32.5 (flight test)	30.0	2.5	+ .5
Convair XF92	35.0 (flight test)	31.0	4.0	2.0
CF-105	35.0 (wind tunnel)	31.0	4.0	2.0

NOTE: All figures in the above table are represented in % m.a.c.

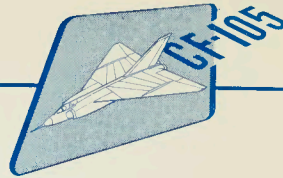

The forward c.g. limit is fixed at 27% m. a. c. with a corresponding take-off speed of approximately 140 knots.

3.3.2.2.1 Summary of C.G. Limits in % M.A.C.: C.G. limits, represented as a percentage of the mean aerodynamic chord, are summarized as follows:-

Forward	Aft
27%	31%

3.3.2.3. Lateral Stability Control: The airplane will possess a small degree of positive static directional stability. This is characteristic of most modern high speed fighters. A further characteristic, which is common to all swept back wings, is the satisfactory dihedral effect which will become somewhat excessive at high lift coefficients. There will be positive dynamic lateral stability (dutch roll) up to a C_L of .65 and altitudes of approximately 20,000 ft., without the use of electronic dampers. In flight at higher lift coefficients and higher altitudes lateral dynamic stability will be augmented to a satisfactory level by an electronic damper incorporated in the autopilot. This will cover the entire speed range of the aircraft.

3.3.2.3.1 Lateral control is achieved by plain flap-type ailerons and the rudder. All the surfaces are fully irreversible and are power operated. The ailerons are capable of giving a maximum rolling performance of 205 deg. per second at all altitudes. (Reference: U.S.A.F. Spec. 1815-B, para. 6.3.4). In the evaluation of these estimates account has been taken of aeroelastic distortions.

3.3.2.3.2 Low Speed Response: It is recognized that delta wings exhibit, in general, a rather sluggish initial response to aileron command at low speeds. This condition is covered by U.S.A.F. Spec. 1815-B, para. 6.3.4 requirement of pb = 10 ft. per sec. for conventional designs. It should be noted that the ailerons on the CF-105 are nearly four times more powerful than the above requirement.

3.3.2.3.3 Wing Dropping: Flight reports on high speed aircraft (e.g. Bell X-1, Douglas Sky Rocket) indicate a very serious and troublesome aspect of transonic flight manifested by a sudden loss of lateral trim. This condition leads to large amplitude lateral oscillations which are extremely difficult to control. It is believed that this phenomenon is, primarily, a function of wing thickness. By using a 3.5% wing section it is assumed that this transonic flight disadvantage will, in all probability, not be encountered on the CF-105.

3.3.2.3.4 The rudder is powerful enough to meet manoeuvring requirements as specified by U.S.A.F. Spec. 1815-B, para. 5.3.

3.4 Structure Design Criteria:

3.4.1 Limit Flight Load Factors: The critical flight envelopes occur at sea level and 30,000 ft. and are shown on Fig. 25 and 26. At sea level, the transonic phenomena are associated with a higher equivalent air speed than at 30,000 ft., thus giving critical conditions for this range. At 30,000 ft. the Mach range reaches the

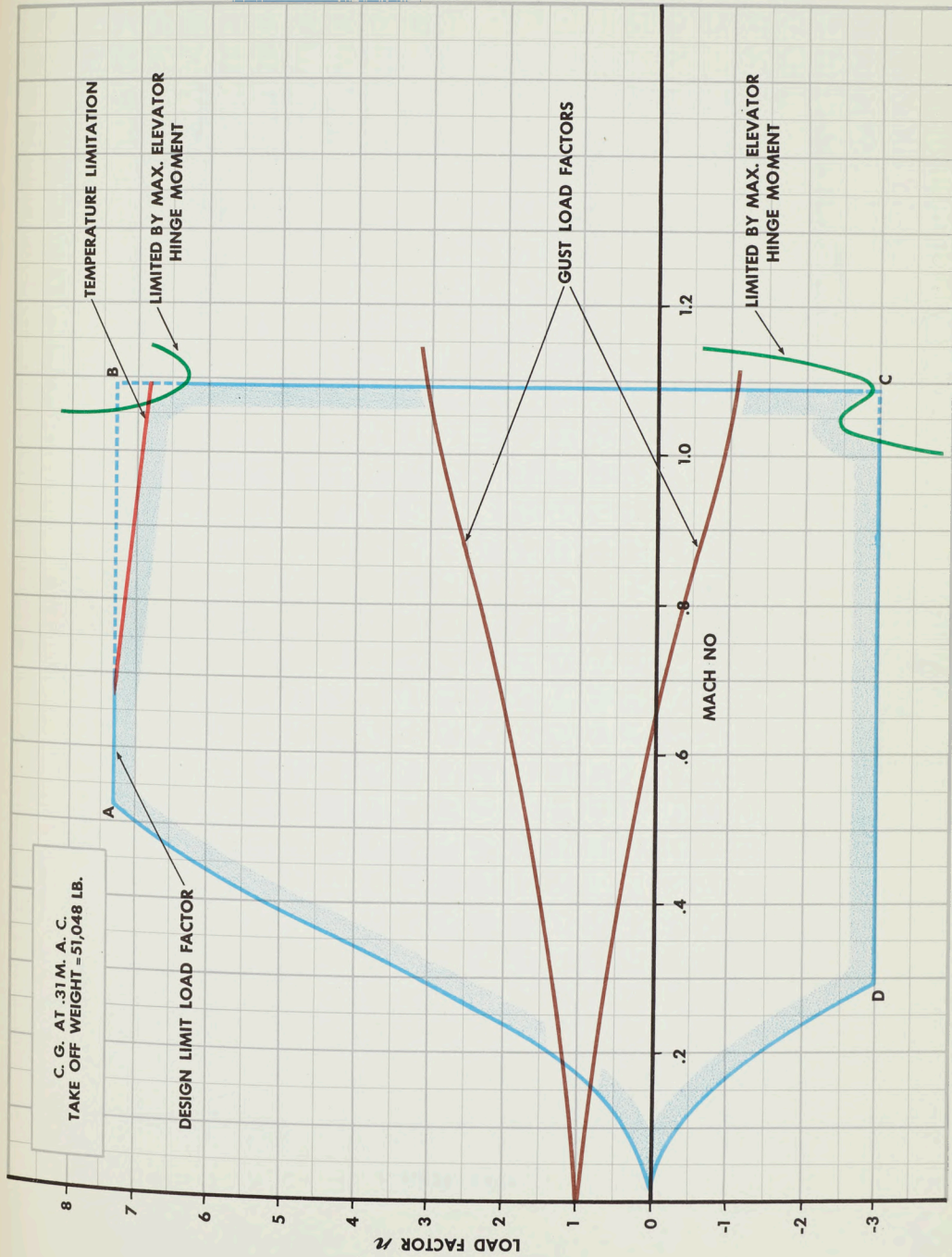
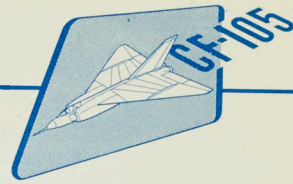

FIG. 25 STRUCTURAL FLIGHT ENVELOPE AT SEA LEVEL

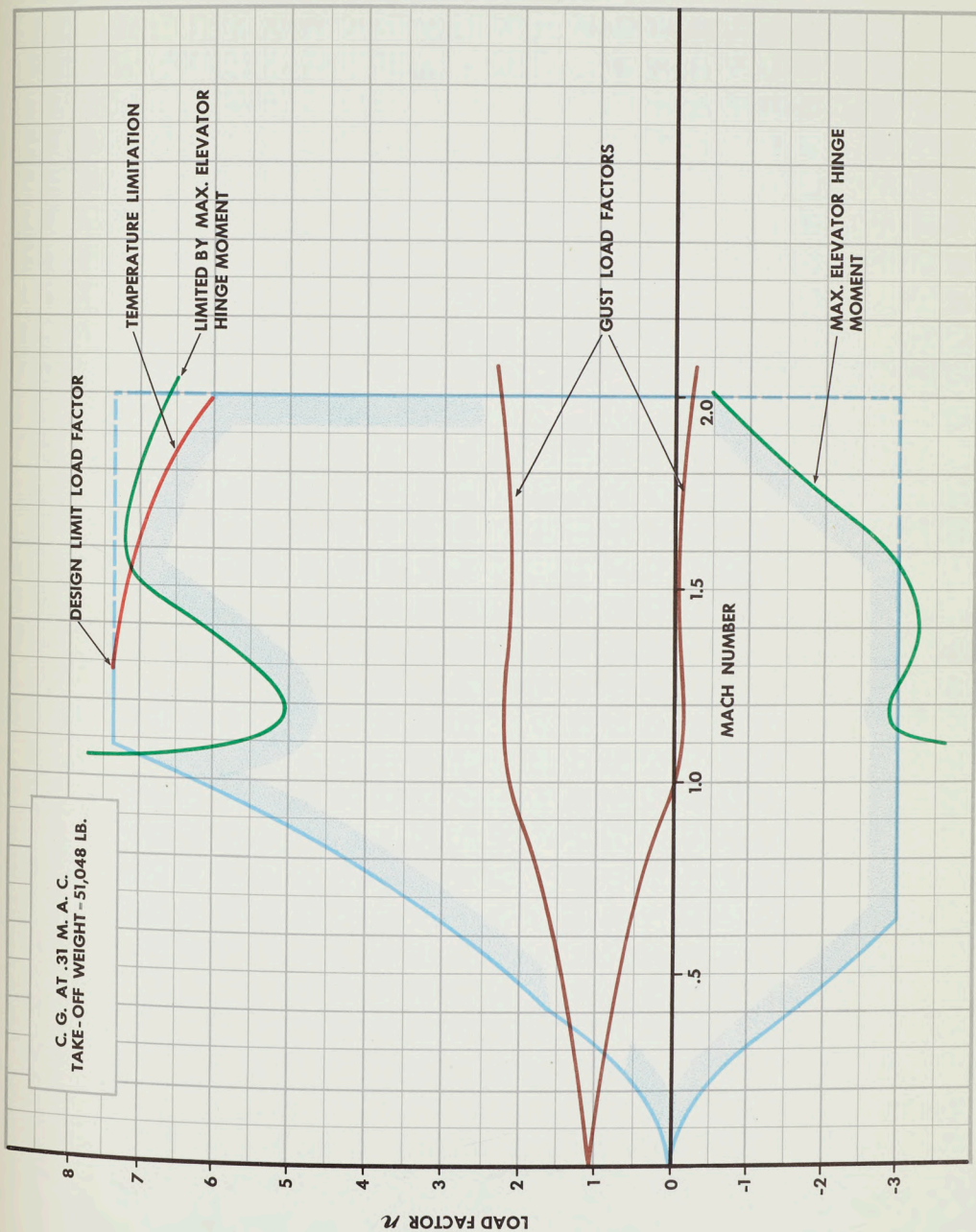
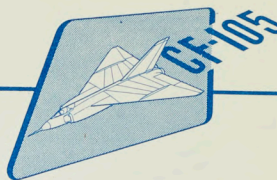

FIG. 26 STRUCTURAL FLIGHT ENVELOPE AT 30,000 FT.

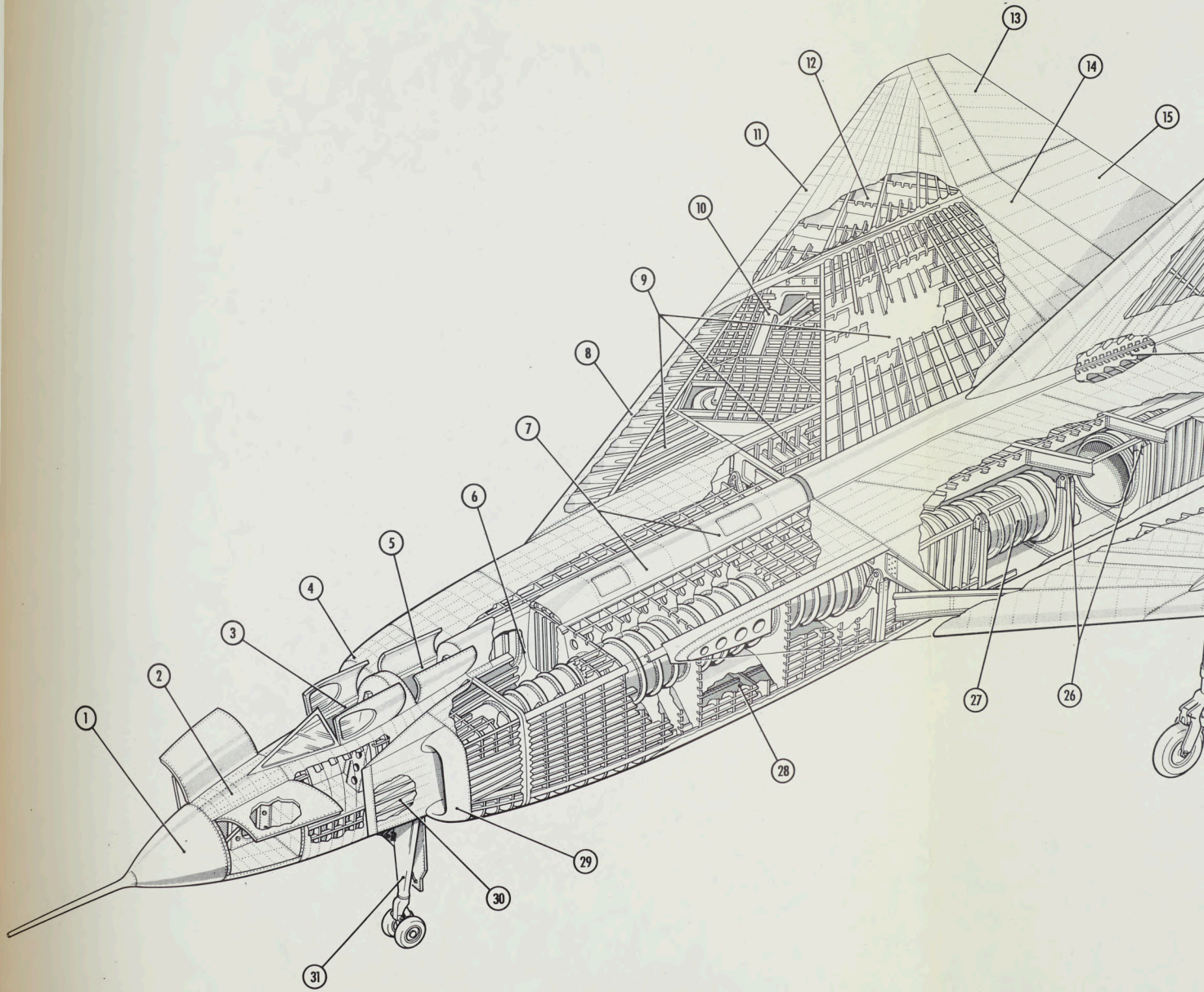

FIG. 27 STRUCTURE ARRANGEMENT

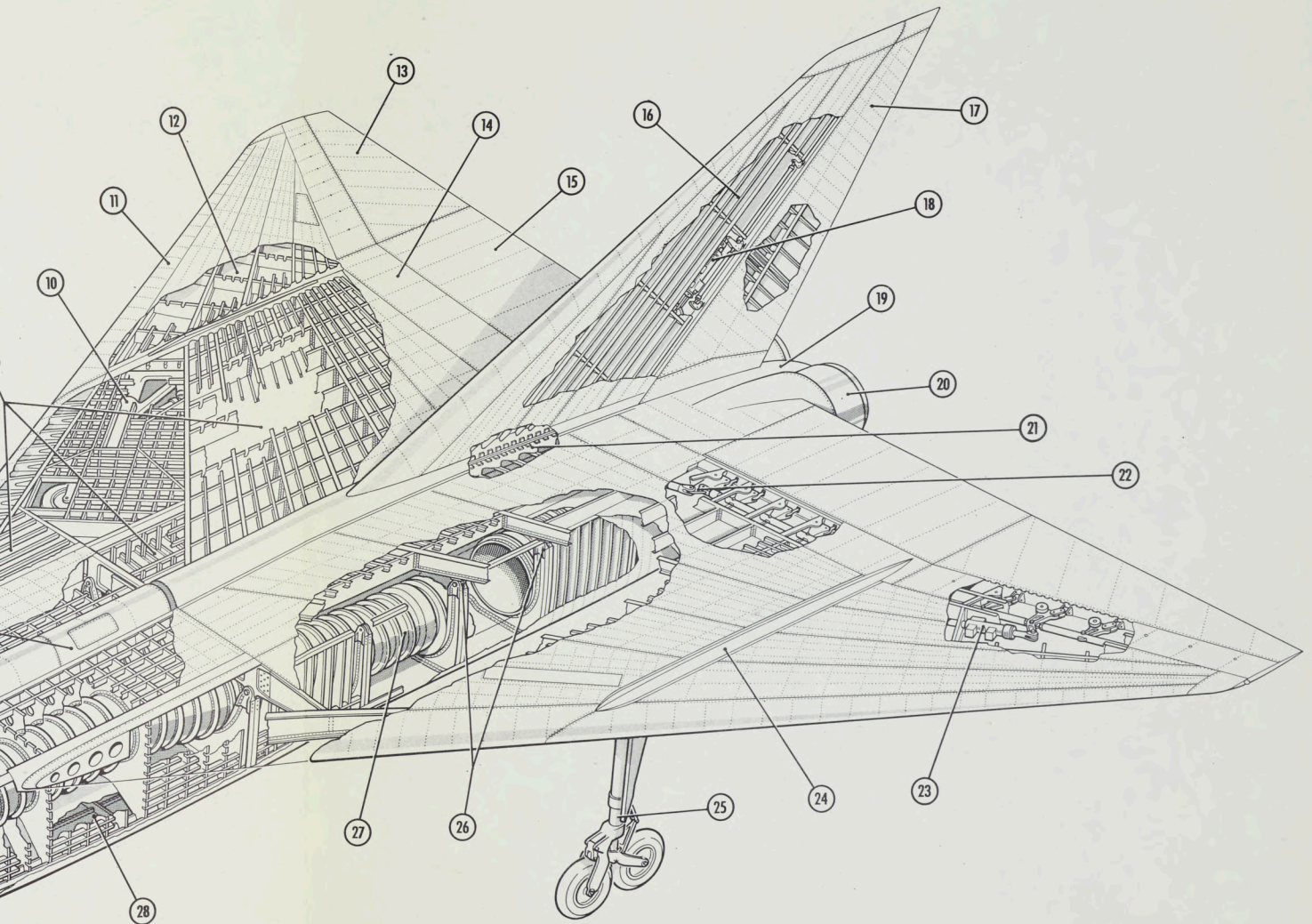
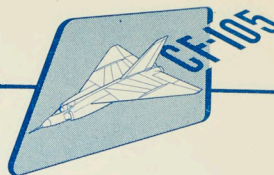

FIG. 27 STRUCTURE ARRANGEMENT



maximum design value, and accordingly must be investigated in its entirety. The elevator limitations have been investigated for a c.g. position extended 1% m. a. c. aft of the aft limit to ensure that the most critical loads are obtained.

3.4.2 Limit Ground Load Factors:

Ground Take-off, $n = 2.5$ at Design Gross Weight
Ground Landing, $n = 2.5$ at Design Gross Weight
Ground Landing, $n = 3$ at Landing Weight = 45,000 lbs.

3.4.3 Design Diving Speed: The design diving speed is either 720 knots EAS or a Mach number of 2.12, whichever is the lesser speed.

3.5 Wing Group:

3.5.1 Description and Components: (Refer to Fig. 27) The wing is of Delta planform, i. e. triangular in shape, and the structure is continuous over the top of the fuselage. The main reason for adopting the high wing configuration is to get better flexibility in the armament bay so that the introduction of larger weapons will not compromise the wing structure and, similarly, with the engines to allow for larger engines to be fitted without basic changes to the structure. The high wing also makes re-arming and engine servicing and changing easier. While the high wing arrangement makes for a longer undercarriage, the employment of 4° anhedral to the wing, which is acceptable from aerodynamic considerations, materially assists in getting a shorter and simpler undercarriage geometry. The wing thickness is 3.5% of the chord at the root tapering to 3.8% of the chord at the wing tip. The wing is manufactured in a number of sub-assemblies which are bolted together at the transport joint (Ref. Fig. 20). These assemblies are:

- (a) Left and right inner wing joined at the fuselage center line.
- (b) Left and right inner wing trailing edges.
- (c) Left and right inner wing leading edges.
- (d) Left and right outer wings.
- (e) Left and right outer wing leading edges.

Left and right ailerons and separate elevators are then fitted to the main wing assembly.

3.5.2 Construction:

3.5.2.1 Inner Wing Assembly: This component consists of a main spar box and separate leading edge and trailing edge. The main spar box has four spanwise spars. The outer surface skin panels are of integral structure, having stringers

LEGEND

- | | |
|-----------------------------------|---|
| (1) Radome and Probe. | (18) Rudder Operating Hydraulic Jack and Control Linkage. |
| (2) Nose Electronics Compartment. | (19) Landing Parachute Stowage. |
| (3) Pilot's Cockpit. | (20) Engine Afterburner Nozzles. |
| (4) R. H. Engine Intake. | (21) Fin/Wing Lap Joint. |
| (5) Radar Operator's Cockpit. | (22) L. H. Elevator Control Linkage. |
| (6) Air Conditioning Equipment. | (23) L. H. Aileron Hydraulic Jack and Control Linkage. |
| (7) Fuselage Fuel Tanks. | (24) Inner/Outer Wing Joint Fairing. |
| (8) Inner Wing Leading Edge. | (25) Main Landing Gear. |
| (9) Wing Fuel Tanks. | (26) Fuselage Frame/Wing Pin Joints. |
| (10) Main Landing Gear Bay. | (27) L. H. Engine Intake Duct. |
| (11) Outer Wing Leading Edge. | (28) Armament Bay. |
| (12) Outer Wing Section. | (29) L. H. Engine Intake. |
| (13) R. H. Aileron. | (30) L. H. Engine Intake Ramp. |
| (14) Inner Wing Trailing Edge. | (31) Nose Landing Gear. |
| (15) R. H. Elevator. | |
| (16) Fin. | |
| (17) Rudder. | |

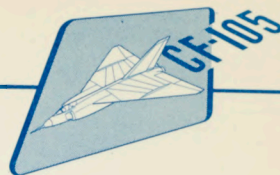

and rib caps machined from a solid billet. The skins and spars form the integral fuel tanks. The main wing transport joint consists of lap plates bolted in double shear. The outer wing joints are covered by a streamlined fairing. The main spar box takes the greater part of the landing gear loads which are transmitted into the box by stout end ribs located at the inner to outer wing transport joint. The fin structure is attached to the main wing by a simple multiplate joint.

3.5.2.2 Inner Wing Trailing Edge Assembly: This assembly is made up of sheet metal skins and forged aluminum alloy ribs. The assembly houses the elevator controlling mechanism which consists of a long push-rod operating six elevator bell cranks.

3.5.2.3 Outer Wing Assembly: This component consists of a multi-cell arrangement of spars and ribs bounded by a leading edge spar and a rear spar, the whole assembly being covered with relatively thick aluminum alloy skin. The spars are of formed channel sections. The ribs are intercostal with shear-attachments through the spars.

3.5.2.4 Outer Wing Trailing Edge Assembly: This component is made up in a similar manner to the inner wing trailing edge assembly with sheet metal skins and forged ribs and houses the aileron controlling mechanism which consists of a long push-rod operating seven aileron bell cranks.

3.5.2.5 Material: In stressing the wing structure, account will be taken of the effect of elevated temperature due to air friction at the design speeds of this airplane. The effect of this temperature, which may reach a value of 250°F at a Mach number of 2, is to decrease somewhat the strength and stiffness of the light alloy material. The skin panels, ribs, and spars are of 75ST high strength aluminum alloy.

3.5.3 Elevator: This component is hinged to the trailing edge assembly of the inner wing by means of a special extruded piano hinge. The elevator is actuated by six push-pull rods equally spaced along the span. Special self-aligning roller bearings are used. The structure of the elevator consists of a leading edge spar and closely spaced ribs covered with thick aluminum alloy skins. A blunt trailing edge is used which will consist of a light alloy extrusion; the reason for this is that this type of trailing edge improves the torsional stiffness considerably and yet causes no additional drag at supersonic design speed. Mass balance or aerodynamic balance devices are not incorporated in the design of the elevator and no tabs are fitted.

3.5.3.1 Elevator Motion: The elevators are fully power-operated by double piston hydraulic jacks; details of the control system are described elsewhere in this brochure. Elevator motion is as follows:-

UP	30 deg.
DOWN	20 deg.

3.5.4 Lift and Drag Increasing Devices: These are not fitted on the wing of this airplane.

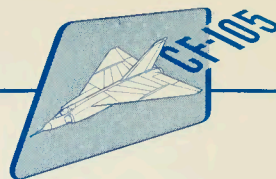

3.5.5 Speed Brakes: These are not fitted on the wing of this airplane (refer to sub-paragraph 3.10.2.2).

3.5.6 Aileron: This component is similar in design and construction to the elevator and is hinged to the outer wing trailing edge assembly by means of a special extruded piano hinge. The ailerons, which are fully power operated, are actuated by seven push-pull rods equally spaced spanwise. As on the elevator, special self-aligning bearings are used. No mass balance or aerodynamic balance is incorporated and no tabs are fitted.

3.5.6.1 Aileron Motion: Details of the aileron control system are discussed elsewhere in this brochure. The motion of the aileron is as follows: -

UP	19 deg.
DOWN	19 deg.

3.6 Tail Group

3.6.1 Description and Components: (Refer to Fig. 27) The tail group consists of a fin and rudder which are situated on top of the wing. The fin is sharply swept back and the maximum airfoil thickness is 3.5% of the chord at the root tapering to 3.8% of the chord at the tip.

3.6.2 Stabilizer: A horizontal stabilizer is not fitted to this airplane.

3.6.3 Elevator: The elevators are fitted to the trailing edge of the wing. Refer to sub-paragraph 3.5.3 for details.

3.6.4 Fin: The fin mounts directly on to the top surface of the wing and its root-shear, bending moment and torque are distributed directly into the wing structure. The structure of the fin consists of a multi-cell arrangement of spars integrated with spanwise rows of vertical members. There are four main ribs attached at 90° to the rear spar, the whole assembly being covered with tapered rolled skins of aluminum alloy. The attachment of the fin to the wing is achieved by means of a multiplate arrangement of aluminum alloy strips forming a series of lap joints to carry the end loads from the main members into the torsion box formed by the wing-to-fin attachment. The trailing edge of the fin aft of the rear spar contains the rudder operating linkage and hinges. This structure is removable as a complete structural unit for servicing and access to the rudder control actuating mechanism. The hydraulic rudder actuating jack and control valves are located in the fin forward of the actuating mechanism. Access to this is provided through a large access door on the left hand side of the fin.

3.6.5 Rudder: This component is hinged to the trailing edge of the fin by five roller bearing hinges on the actuating levers and two plain hinges bolted to the right hand skin surface.

3.6.5.1 Rudder Motion: The rudder is fully power-operated by a double piston hydraulic jack and has a motion of 30 degrees either way. Details of the control system are described elsewhere in this brochure.

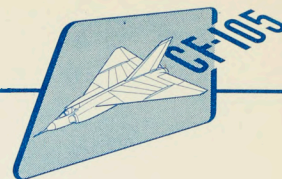

3.7 Body Group:

3.7.1 Fuselage:

3.7.1.1 Description: (Refer to Fig. 27) The fuselage is slung underneath the wing. The cross-section over a good portion of the length is almost rectangular with rounded corners. The fuselage accommodates the pilot and radar operator, nose landing gear, the armament and equipment bays, engine intake ducts, speed brakes, engines and afterburners, flying and power plant controls, fuselage fuel tanks and brake parachute. The fuselage is manufactured in six sections, made up as separate units and bolted together at transport joints (Ref. Fig. 20). From front to rear these consist of:

- (a) The radome and probe section.
- (b) The nose electronics section.
- (c) The front fuselage section containing the cockpit, intakes, fuselage fuel tanks, armament and equipment.
- (d) The fuselage center section containing the speed brakes and equipment.
- (e) The rear fuselage section containing the engines and afterburners.
- (f) The tail cone section.

3.7.1.2 Construction:

3.7.1.2.1 Radome Section: The radome houses the nose probe which in turn contains the pitot-static head, the relative wind sensors for the air data computer and the radome de-icing fluid dispenser. The radome is made of suitable dielectric material of sandwich construction. Anti-icing is provided.

3.7.1.2.2 Nose Electronics Section: The main bulk of the radar equipment is housed in this section which is made up as a separate component with large side access doors for ease of servicing.

3.7.1.2.3 Front Fuselage Section: This is the largest fuselage component. It houses the pilot's and radar operator's compartments, the fuselage fuel tanks, the equipment installation section (including air conditioning equipment), and the armament bay. The general structure follows conventional practice, using formers, stringers, and skin construction, mostly of 75ST high strength aluminum alloy. The crew compartment is pressurized and has clamshell type canopies which may be operated either from outside or inside the aircraft. A "V" type windscreen is

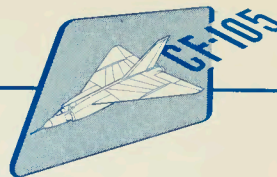

fitted for aerodynamic reasons. This type of windscreen improves the flow over the canopy and cuts down the drag to a minimum, and is so arranged that the optical properties are adequate. Provision is made for anti-icing and de-misting. The front fuselage section also houses the nose landing gear. Engine side intakes are used with supersonic intake ramps on the inboard portion of the intake lips. The engine ducts run from an almost rectangular section at the intake to a circular section just aft of mid-length. The engine intake ramps are wedge-shaped and are fitted to get good pressure recovery characteristics in the intakes at supersonic speeds. These ramps are integral with the intake lips and also form the boundary layer bleed. The boundary layer bleed is approximately of triangular shape with the centre portion feeding the air-cooling turbine for the air conditioning system.

Bag type fuel tanks are carried in this portion of the fuselage. Special attention has been given to housing equipment to achieve ease of servicing and maintenance, and the wide fuselage required by the twin engine installation has been utilized to the fullest extent to provide a very large armament bay. The armament bay below the fuselage is approximately 19 ft. long x 7 ft. 8 in. wide x 2 ft. 1 in. maximum depth and accommodates eight Hughes 'Falcon' missiles or weapons of equivalent size.

3.7.1.2.4 Fuselage Center Section: The center section of the fuselage houses the fuselage speed brakes and a proportion of aircraft equipment.

3.7.1.2.5 Rear Fuselage Section: This assembly is a continuation of the front fuselage structure. The primary structural elements consist of a series of transverse frames pin-jointed at their outboard flanges to the under side of the wing and carry two circular tunnels side-by-side which house the engines and afterburners. The centre structure consists of the lower inboard quadrants of the two tunnels, and a horizontal "cat walk" between them, which is supported through pairs of struts pin-jointed to the center of the wing.

No stringers are used, but a longeron is used at the lower outboard portion of the structure. The two engine tunnels of titanium material for fire resistance, are pressure vessels attached to all frames around the lower halves with independent support for the top halves. Direct attachment of the tunnels at the forward end to the rear of the air intake is achieved through a semi-flexible joint. This structure takes aerodynamic loads only, since all engine and afterburner loads are taken directly through the main wing structure.

3.7.1.2.6 Tail Cone Section: This assembly forms a completely detachable fairing of monocoque construction containing the continuation from the rear fuselage section of the two engine tunnels, a landing parachute with operating mechanism and the rudder fairing. The unit is attached to the rear of the main fuselage through eight quick release toggle action fasteners. The main functions of this unit are to transmit parachute landing and tail skid loads to the rear fuselage section, and to provide a fairing around the two afterburner nozzles. Engine removal and installation are accomplished by detaching the whole unit to permit the engine to roll on tracks through the rear of the power plant bays.

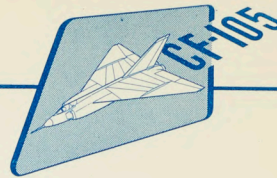

3.7.1.3 Crew Station: The crew consists of pilot and navigator/radar-operator, both seated in automatic type ejection seats. The pilot is provided with normal flying and engine controls, a radar scope, flight instruments, switches, etc. to enable the aircraft to be flown at all times, if necessary, by a pilot alone. The navigator/radar-operator, is provided with a radar scope, the essential flight instruments and the main radar controls to monitor the attack, including lock-on. (It is intended to fit the MX.1179 single-man fire control system when available, at which time the navigator/radar-operator station will become redundant.) The cockpit is pressurized to a pressure differential of 4.5 lb. per sq. in. and is fully temperature-controlled. Special attention has been given to the pilot's view, both forward over the nose for landing, and to achieve the best presentation of instrument and equipment panels. Escape is achieved automatically by simple selection which opens up the canopy and fires the automatic seat.

3.7.1.4 Cargo Compartment: Cargo compartments are not fitted in this airplane.

3.7.1.5 Equipment Compartments: These have already been outlined in the preceding paragraphs dealing with the fuselage. Reference may further be made to the equipment illustrations in this brochure and the paragraphs dealing with equipment.

3.7.1.6 Speed Brakes: The speed brakes consist of two separate flaps mounted on the under-side of the fuselage center section flush with the outside contour and are actuated by independent hydraulic jacks which rotate the flaps into the air stream.

3.7.2 Hull: Not applicable to this airplane.

3.8 Alighting Gear:

3.8.1 General Description and Components: (Refer to Fig. 27) The alighting gear is the conventional type of tricycle undercarriage. The nose undercarriage retracts forward into a compartment below the pilot's floor. The main undercarriage folds sideways and forwards into a compartment inboard of its pivot-axis inside the wing. The main gear consists of a two-wheel bogie. The main wheels are positioned relative to the centre of gravity of the airplane so that a line drawn from the aft c. g. limit of the airplane (31% m. a. c.), and normal to the tail down static ground line, passes through the center of the bogie chassis pivot axle; this line makes an angle of $15^{\circ} 20'$ with a line drawn normal to the wing chord. The angle between the wing chord and the static tail up ground line is $3^{\circ} 55'$.

3.8.2 Main Landing Gear:

3.8.2.1 Description: This gear consists essentially of a two-wheel bogie. Retraction is effected about an inclined pivot axle, the motion of the gear being inboard and forward, so that the wheels in their retracted position are considerably ahead of their extended position. Due to the inclination of the pivot axle in plan view, it is necessary to rotate the bogie chassis about the leg centre line during retraction, by about 45° . The whole gear will be made quickly detachable from the airplane. For

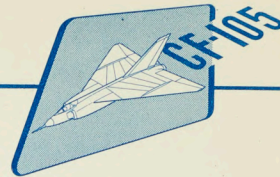

this reason, the main pivot shaft is designed so that it can be extracted through a detachable portion of the wing leading edge. It is proposed to use needle bearings wherever possible; this is in accordance with best contemporary practice and results in lower friction losses during retraction and hence smaller hydraulic jacks.

3.8.2.2 Wheel Brakes and Brake Control System: The main wheels will be fitted with brakes which will be operated hydraulically by means of links connected to the rudder pedals. These pedal links are connected to hydraulic valves which meter the hydraulic fluid to the brakes. A hand operated parking brake will be installed in the cockpit. The brake drums of the front and rear wheel of the bogie are interconnected by a link, so that the braking torque from the rear wheel is transmitted to the front drum. The total torque is then transmitted from the front drum to the undercarriage leg, via another link and the bogie chassis.

3.8.2.3 Tires and Tubes: The tire size will be 29" x 7.7".

3.8.2.4 Shock Absorbers: The main shock absorber, which will be of the liquid spring type, is housed inside the leg casing. Total travel is of the order of twelve inches. In addition to the main shock absorber, there is a small damper strut. This damper strut connects the bogie chassis to the main leg and serves the following purposes:-

- (a) To damp out oscillations of the bogie due to sudden load transference between the front and rear wheels during wheel spin-up and braking while landing the airplane.
- (b) To act as a spring to position the bogie in its correct touch-down attitude prior to landing.
- (c) To act as a subsidiary to the main shock absorber during the early part of a touch-down.

The damper strut will be designed so as to completely eliminate the usual high drag and anti-drag design cases. This may be accomplished as follows. The damper strut spring will position the bogie - chassis so that the rear wheel will hit the ground first. The characteristics of the damper will be made such that spin-up of this rear wheel is accomplished completely before the front wheel hits the ground, with its subsequent spin-up drag load. This characteristic along with the fact that the wheel inertias, resisting spin-up, are small due to the relatively small wheels results in a very low drag load on the main gear. In fact, the bogie arrangement acts so as to spread out, over a longer period of time, the initial shock at landing and wheel spin-up. Furthermore, the usually critical spring back condition, causing high anti-drag forces on a landing gear, is completely eliminated by this mechanism.

3.8.2.5 Retracting, Extending and Locking Systems: Emergency lowering in case of hydraulic failure will be effected by compressed air stored at 3000 lb. per sq. in.

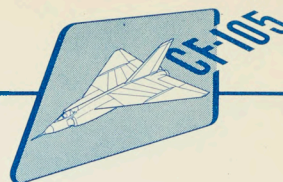

3.8.2.6 Doors and Fairings: The bogie-chassis and wheels are covered by a large hydraulically operated door which hinges from the bottom surface of the wing close to the fuselage side. The hinge line will be parallel to the airflow. The outboard portion of the main gear leg and retracting mechanism is covered by a door which is linked to the main leg but which hinges about a line parallel to the airflow. A narrow fairing between these two doors is mounted rigidly on the main gear leg.

It is proposed that, in the retracted position, the main gear be supported by the large door covering the bogie-chassis. This door will be hooked to the wing structure and positively locked in the up position.

3.8.2.7 Inspection and Maintenance: Special care is being taken to provide maximum accessibility for maintenance and inspection.

3.8.3 Auxiliary Landing Gear - (tail wheel): A tail wheel unit will not be fitted on this airplane.

3.8.4 Auxiliary Landing Gear - (nose wheel):

3.8.4.1 Description: The nose landing gear is a single leg levered suspension unit with a liquid spring shock absorber. The axle travel for shock absorption is 10". Dual nose wheels are employed. Nose wheel steering is provided by a spring centered steering cylinder attached to the main leg strut and steering is controlled through a mechanical linkage between the rudder pedals and the steering valves. Shimmy damping is provided.

3.8.4.2 Wheel Brakes: These will not be fitted on the nose wheel.

3.8.4.3 Tires and Tubes: The tire size will be 18" x 5.5".

3.8.4.4 Shock Absorber: This will be of the liquid spring type, manufactured by Dowty Equipment Limited.

3.8.4.5 Retracting, Extending and Locking Systems: Emergency lowering in the case of hydraulic failure will be effected by compressed air stored at 3000 lb per sq. in.

3.8.4.6 Doors and Fairings: The main nose wheel door is attached to and swivels with the main leg structure. Two small auxiliary doors covering the wheel are hydraulically operated.

3.8.4.7 Steering Control: Refer to para. 3.8.4.1.

3.8.4.8 Inspection and Maintenance: Special care is being taken to provide maximum accessibility for maintenance and inspection.

3.9 Alighting Gear (water type): Not applicable to this airplane.

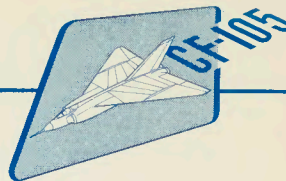

3.10 Surface Control System:

3.10.1 Primary Flight Control Systems: The primary flight control surfaces comprise:-

- (a) An elevator, mounted on the inboard trailing edge of each wing
- (b) An aileron, located outboard of the elevator on each wing, and
- (c) A rudder.

These installations are illustrated in Fig. 27. All three surfaces are actuated by irreversible hydraulic jacks which are connected to the related surfaces at multiple points through a combined push rod/bellcrank linkage (refer to Fig. 27). By using piano-type hinges on the ailerons and elevators, the whole mechanism can be housed internally. This method of operating the surfaces reduces very greatly the stiffness required from them and, in consequence, serves to lighten them. Mass balance is not required and the amount of twist under load is negligible. This internal system is not applicable to airplanes incorporating elevon control, due to the high tip loads and cannot be successfully used on very small airplanes owing to space restrictions. Two pistons are fitted to each hydraulic jack. These are actuated by the separate hydraulic systems as outlined in sub-paragraph 3.15.1.1.1. Artificial 'feel' for the pilot is obtained by a suitable spring system which can be biased to give trim conditions (refer to sub-paragraph 3.10.3). A bob weight is provided in the longitudinal control circuit in order to sense 'g' applications. In general, the system will be similar to that used on the F86E airplane.

3.10.2 Secondary Flight Control Systems:

3.10.2.1 Lift and Drag Increasing Devices: Lift increasing flaps are ineffective on this type of wing planform and, in consequence, are not fitted. Drag at landing speed is greatly increased by the release and subsequent streaming of a tail parachute. This item is stored in a housing (covered by a quick-release end cap) in the tail cone (Fig. 27). The method used for parachute ejection is similar to that required for anti-spin purposes. Successful development of this equipment has been reached on the AVRO 707 series of airplanes. Initially, the ejection will be manually controlled from the cockpit; later it is intended that the parachute release is tied in with the automatic landing system. The parachute diameter is 24 feet.

3.10.2.2 Speed Brakes: Speed brakes are fitted on the bottom of the fuselage as illustrated in Fig. 20, and are positioned to give minimum change of lift or pitching moment when opened up to Mach No. = 1.0. Adequate ventilation between the brake flaps and the adjacent surface is provided to ensure freedom from buffeting at all speeds. The location of the brakes is such that a minimum of interference with the primary flight control surfaces is obtained. Hydraulic jacks, limited in capacity so that the flaps will blow down when a fore-and-aft acceleration of .33 g

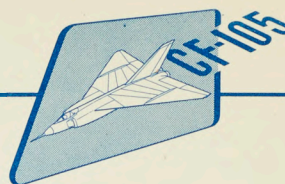

is exceeded, are used to operate the brakes. The maximum time from brakes closed to opened will not exceed three seconds.

3.10.3 Trim Control System: Trim is effected by adjusting the centering position of the spring system which gives artificial feel to the primary flight controls. Tabs are not fitted since these would be ineffective with irreversible controls.

3.10.4 Automatic Pilot: This airplane is designed to be operated almost entirely under automatic control. For this reason the auto-pilot must be integrated with the automatic navigation, fire control and landing systems, while still exercising those functions normally associated with an auto-pilot. Elaborating on this requirement, provision will be made for:-

- (a) Damping of at least 60% critical, about all three axes for both short and long period oscillations.
- (b) Turns to be co-ordinated so as to eliminate sideslip irrespective of drag asymmetry.
- (c) The response of the system will be such as to give a smoothing time with respect to a steering signal of 0.2 seconds for purposes of fire control. Steering signals from all sources are computed relative to a gyro-stabilized platform which uses the earth's gravitational and magnetic fields as primary references in the normal manner. The method of deriving the automatic steering signals is referred to in sub-paragraph 3.17.7.

Suitably amplified voltages are then fed to the servo motors. The servo motors are just powerful enough to operate the hydraulic control valves and, accordingly, can be over-riden easily by the pilot at any time. The force necessary to accomplish this operation will be of the order of 30 lb. It will also be possible to disconnect any or all of the steering channels from the auto-pilot without affecting automatic stabilization and damping. It should be noted that although it will be possible to fly the airplane with the auto-pilot completely disconnected, the synthetic damping will normally be retained even if all the other functions are rendered inoperative. As far as possible, auto-pilot failure will be arranged to exclude possible flight hazards and a system to cater for checks on the circuits will be incorporated in the basic design.

3.11 Engine Section:

3.11.1 Description and components: (Refer to Fig.28). The engines and after-burners are housed in the rear section of the fuselage as has been described in sub-paragraph 3.7.1.2.5 and 3.7.1.2.6. Refer also to sub-paragraph 3.12.3.

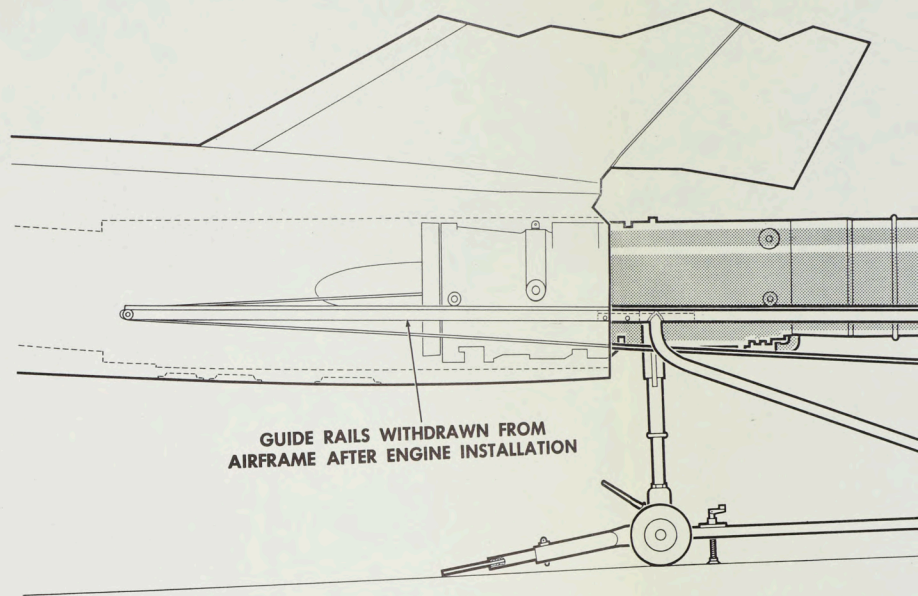

GUIDE RAILS WITHDRAWN FROM AIRFRAME AFTER ENGINE INSTALLATION

ENGINE INSTALLATION AND REMOVAL

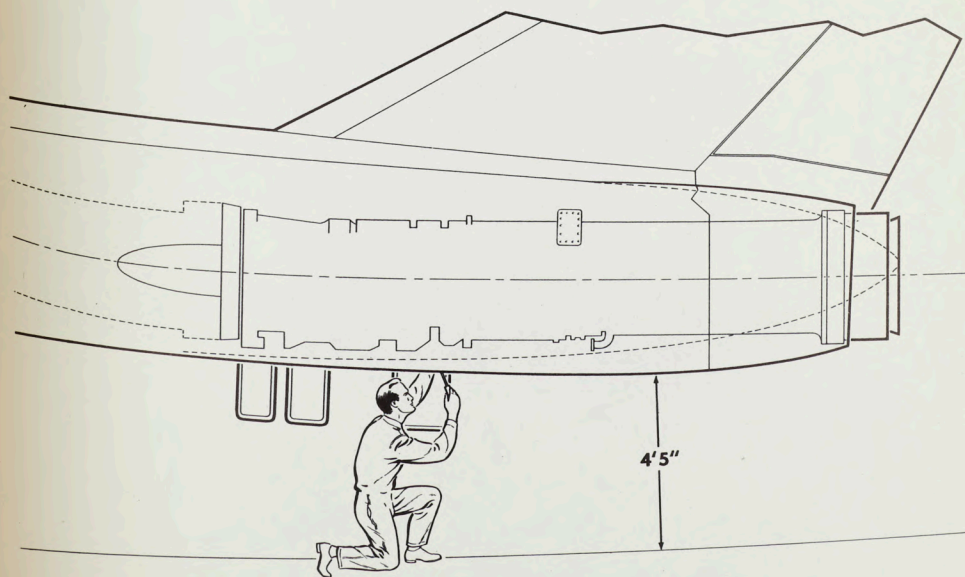

ENGINE SERVICING

FIG. 28 ENGINE INSTALLATION AND REMOVAL

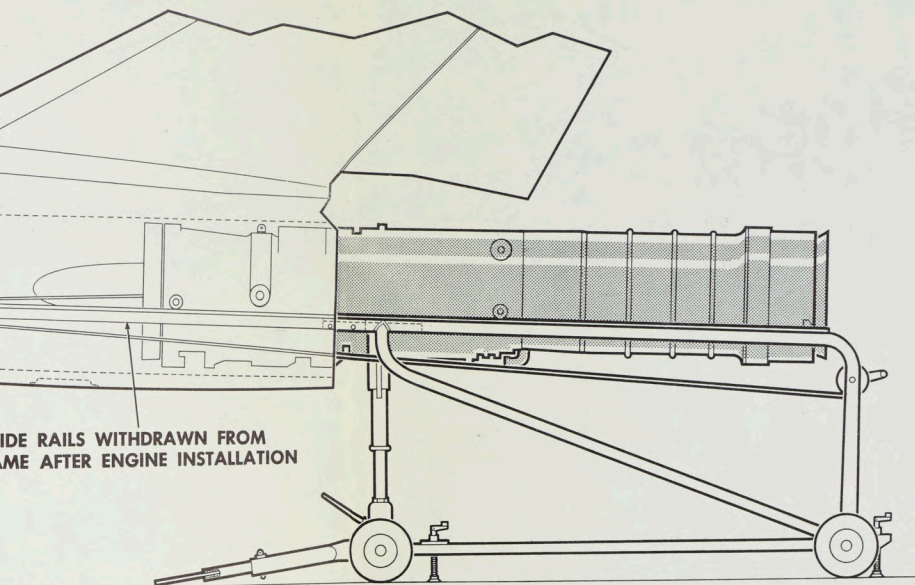

ENGINE INSTALLATION AND REMOVAL

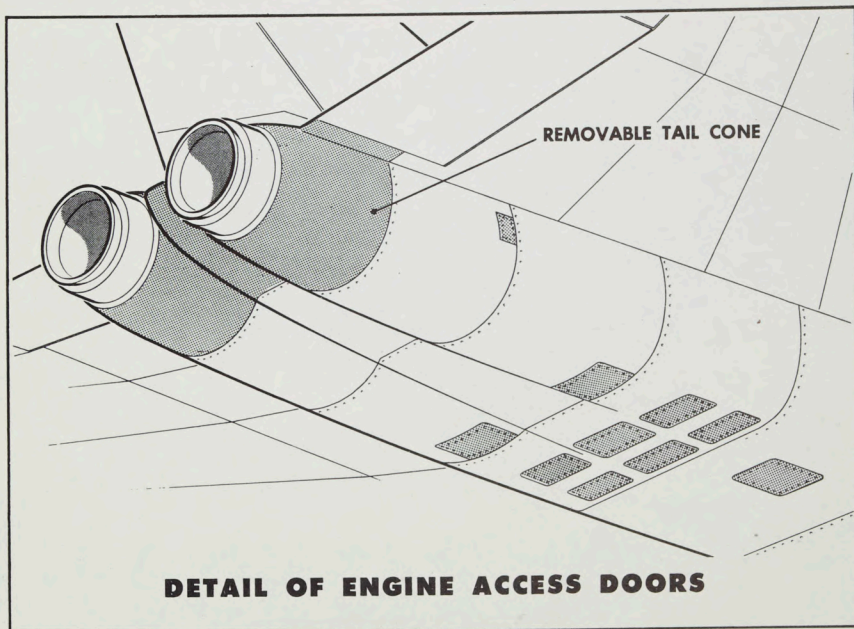
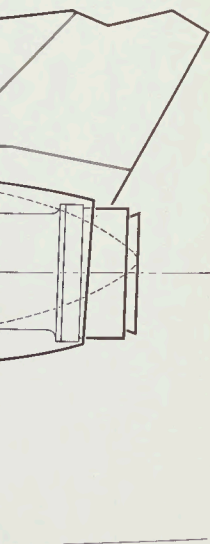

DETAIL OF ENGINE ACCESS DOORS

FIG. 28 ENGINE INSTALLATION AND REMOVAL

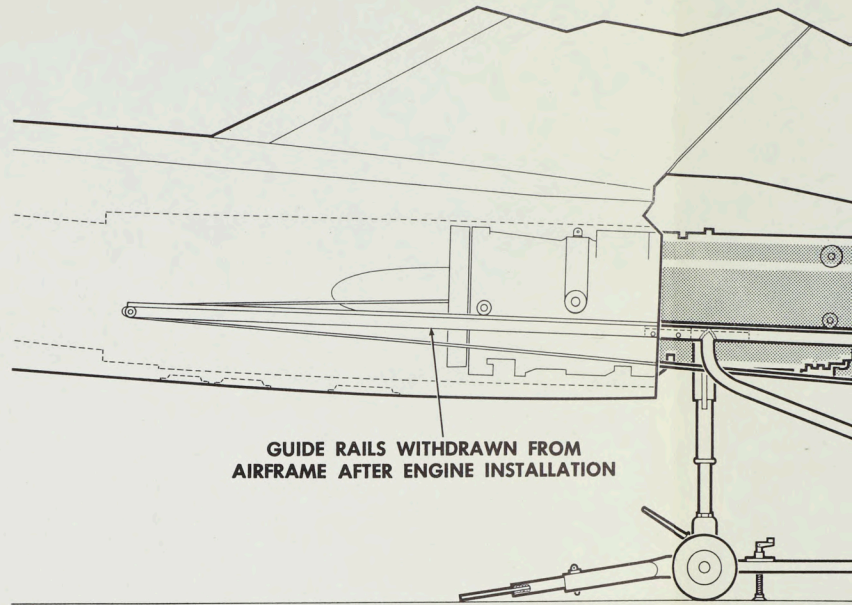

ENGINE INSTALLATION AND REM

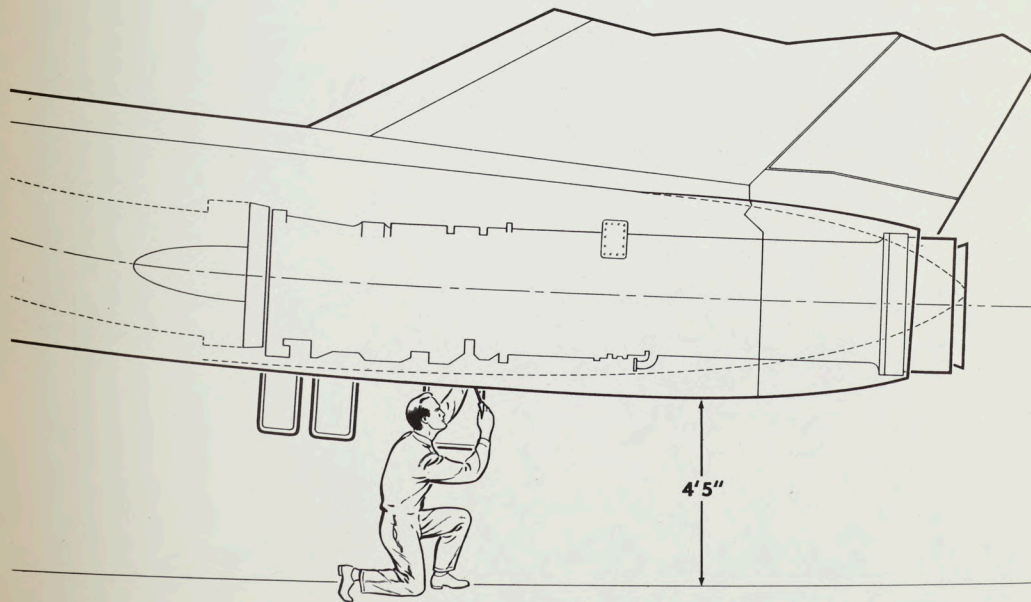

ENGINE SERVICING

FIG. 28 ENGINE INSTALLATION AND

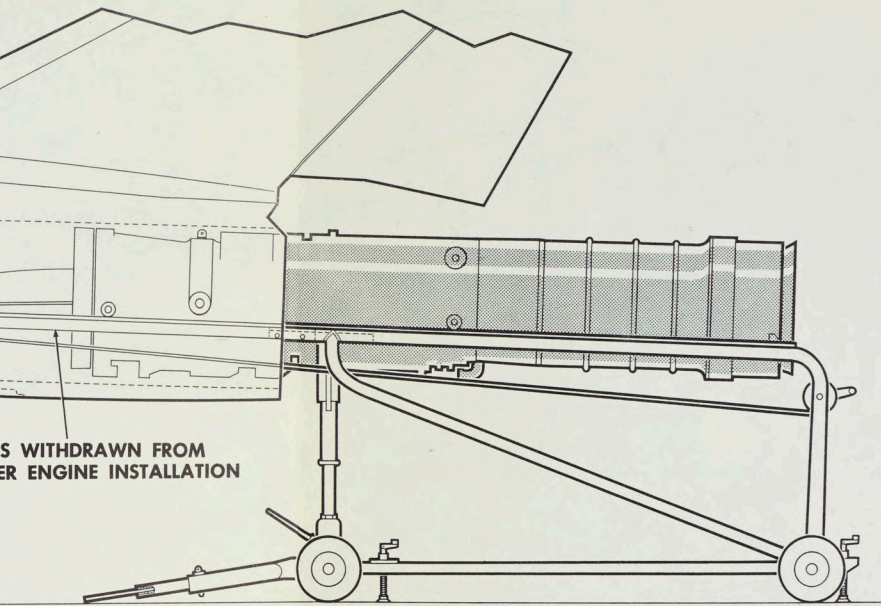

...S WITHDRAWN FROM
...ER ENGINE INSTALLATION

ENGINE INSTALLATION AND REMOVAL

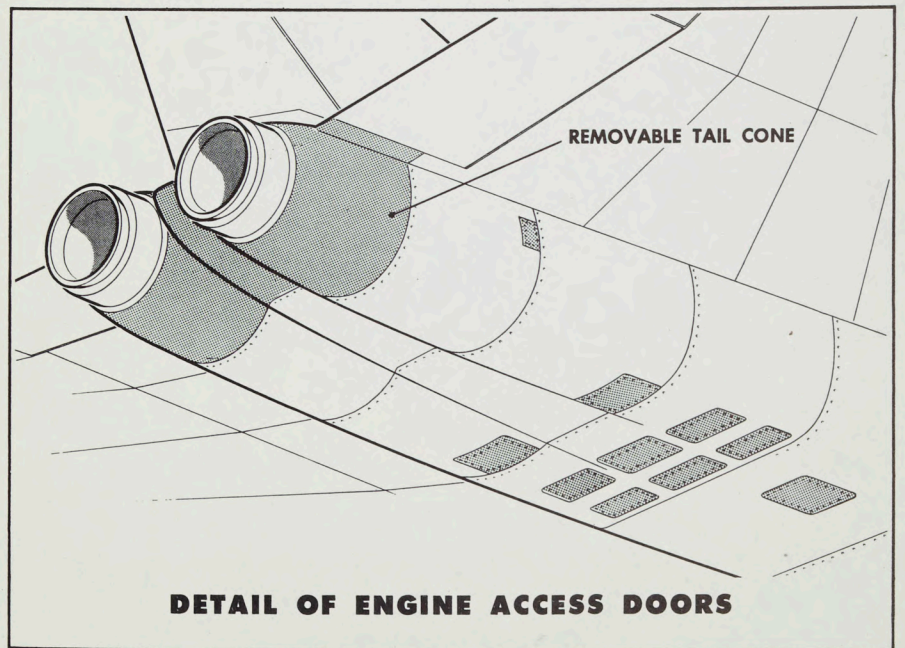
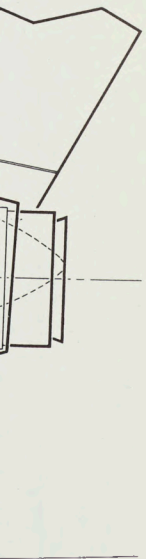

DETAIL OF ENGINE ACCESS DOORS

ENGINE INSTALLATION AND REMOVAL

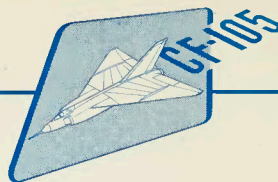

3.11.2 Construction: Refer to the references mentioned in the preceding subparagraphs.

3.11.3 Engine Mounts: The engines are each supported at three points - two of which are on the engine interstage compressor housing, and the third on the turbine shroud ring. There are three permissible front attachment points on the interstage housing, of which two are used in each engine installation, - the one at the top of the engine on the vertical center is used to transmit vertical, side and thrust loads, whereas the second front mount is on the inboard side of each engine on the horizontal center line and takes vertical loads only. The third available front mount on the outboard side is not used. There are two available attachment points for rear mounting at 45° above the horizontal. The outboard pick-up is used for vertical and side loads only. The afterburners are cantilevered from the engine rear flange and no additional support is required.

3.11.4 Vibration Isolators: These will not be fitted.

3.11.5 Fire Walls: Each complete engine and afterburner is housed in a cylindrical shroud of titanium sheet, which isolates the power unit from the remainder of the aircraft, with the exception of the air intake. Separation of the compressor or fuel section of the engine from the combustion zone is achieved by an additional titanium shroud around the afterburner and combustion chamber of the engine, attached to the engine prior to installation in the main shroud or tunnel. A stainless steel transverse fire-wall around the rear end of the compressor section is supplied with the engine and forms the forward support and seal of the engine dividing fire-wall shroud.

3.11.6 Cowling and Cowling Flaps: These are not applicable to this airplane.

3.11.7 Access for Inspection and Maintenance: Three pressure doors are provided under the compressor section of the engine for maintenance and access to airframe/engine connections on engine removal. Two small pressure doors are provided in the combustion zone to provide access to the rear engine mount and to the afterburner fuel and hydraulic equipment.

3.12 Propulsion:

3.12.1 General Description and Components: The airplane is propelled by two turbojet engines, each with an afterburner. The complete installation is mounted inside the rear of the fuselage as shown in Fig. 28.

3.12.2 Main Propulsion Unit: Curtiss-Wright-Y. J. 67-W-1 turbo-jet engines with integral afterburners will be installed in the prototype aircraft. These engines each develop a maximum sea level static thrust of 13,200 lbs. dry and 21,500 lbs. with full 2,000°K afterburning. The J. 67 is a 10.5/1 pressure ratio, two-spool axial flow engine. The two mechanically independent compressors of five and seven stages in series are separated by an intercompressor housing and bearing

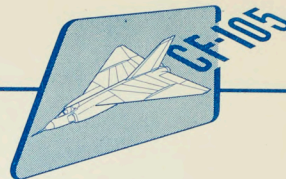

support with an integral engine component gearbox at the bottom. Power take-offs are provided through the front mounting pads in the three positions described in para. 3.11.3. A nose pad is provided in the front main bearing support for driving a 40 KVA alternator. Estimated specific fuel consumptions are as follows:-

- (1) With full afterburner: 2.05 lb/hr/lb thrust.
- (2) Military: .795 lb/hr/lb thrust.
- (3) Normal: .760 lb/hr/lb thrust.

The engines to power the production aircraft have yet to be decided.

3.12.3 Mounting, Access and Removal: (Refer to Fig. 28).

3.12.3.1 Mounting: The engine/afterburner units are mounted directly from the under side of the wing. The top front mount is a fixed position ball type mounting, accessible from the upper surface of the wing. The side front mount is a strut ball-jointed at the under side of the wing and at the horizontal center line of the engine. Strut length is adjustable to allow accurate roll alignment of the engine. The rear mount loads are transmitted through a torque tube forward into the wing structure and this mount is adjustable in the transverse vertical plane for nozzle alignment. Allowance is made for expansion. All mounts are so designed that the operation of making the attachment of engine to airframe also raises the engine 3/8". (Refer to para. 3.12.3.3)

3.12.3.2 Access Provisions: Access to the engine is made through the doors mentioned in 3.11.7, which provide for all normal servicing requirements. If access should, for any reason, be required to the upper part of the engine or to the alternator and constant speed drive, it will be necessary to remove the engine.

3.12.3.3 Engine Removal: Procedure for removing an engine is as follows:-

- (1) Remove fuselage tail cone.
- (2) Open access doors and uncouple all fuel, air and electrical connections.
- (3) Insert assembly rails through rear of fuselage and adjust engine handling trolley to line up with assembly rails.
- (4) Uncouple rear mount, front side mount and front top mount in that order.
- (5) Withdraw engine from aircraft on to trolley.

3.12.4 Engine Driven Accessories: A 40 KVA alternator is mounted on the nose pad provided with the engine. Accessories gearboxes are provided, one driven by



each engine through its side mounting pad. Two hydraulic pumps are mounted on each box for operation of the flying controls and a further hydraulic pump, on one box only, services the utility system. A spare pad on each box, making three in all, is provided for possible future use. An additional take-off from each of these gearboxes provides shafting and gearing to drive the fuel system booster pump. Access to the gearboxes is made through two doors between the two engines on the under side of the fuselage.

3.12.5 Air Induction System:

3.12.5.1 Description and Components: The air induction system consists of the air intake ducts described below.

3.12.5.2 Air Intakes: Engine side intakes are used with supersonic intake ramps on the inboard portion of the intake lips. Boundary layer bleed is also provided between the ramp and the fuselage. The engine ducts run from almost rectangular section at the intake to a circular section just aft of mid-length.

3.12.5.3 Ice Protection System: Compressor entry de-icing equipment will be provided by the engine manufacturer as an integral part of the engine. The lips of the air intake ducts will be de-iced by passing hot air, bled from the engine compressor, through the annular space between the inside and outside skins.

3.12.5.4 Dust Protection System: To be resolved.

3.12.6 Exhaust System: This system is not applicable in this airplane.

3.12.7 Cooling System: This is shown in Fig. 29.

3.12.8 Lubricating System: A self-contained system will be provided as an integral part of the engine.

3.12.9 Fuel System:

3.12.9.1 Description and Components: (Refer to Figs. 30, 31 and 32) The total internal fuel capacity is 20,190 lbs. (at 7.5 lbs/Imp. Gall.) of usable turbine fuel which is contained in a number of tanks situated in the wing and in the fuselage. All wing tanks are of integral construction, while the fuselage tanks are of the "bladder-cell" type. The fuel system will supply fuel to the engines and the afterburners under all flight conditions, including inverted flight. Two immersed type booster pumps, which are located in the inner wing tanks just aft of the main spar and close to the aircraft center line, supply the engines and afterburners. Normally, the pump located in the left tank supplies the left engine and afterburner, while the pump located in the right tank supplies the right engine and afterburner. These left and right inner wing tanks in which the booster pumps are located are not interconnected, and each tank forms a collector nucleus for the appropriate side of the nearly symmetrical right hand and left hand fuel systems. Fuel is transferred, by

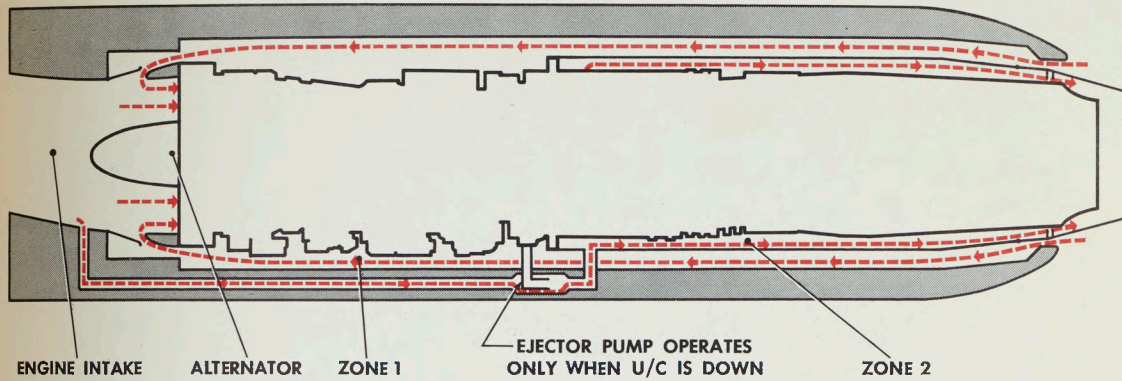

**FLIGHT (M=.25 - 1.50)
AIR COOLING & VENTILATION**

APPROX. AIR FLOWS

- ZONE 1 1/4 LB./SEC. TO 2 LB./SEC.
- ZONE 2 1/4 LB./SEC. TO 3 LB./SEC.

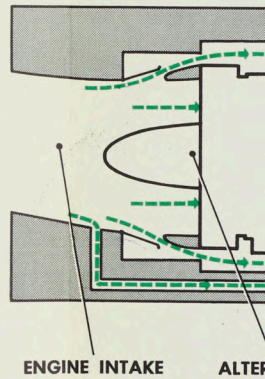

DUMP FLAPS OPEN AT SPEEDS > M=1.5

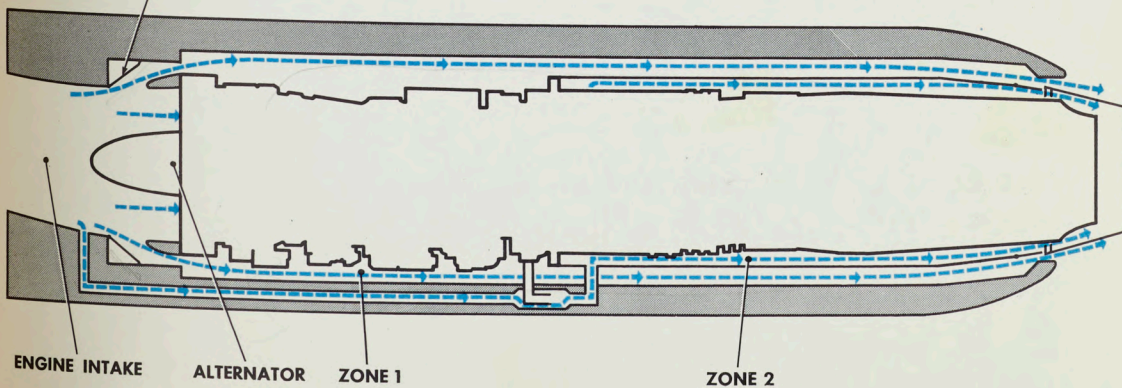
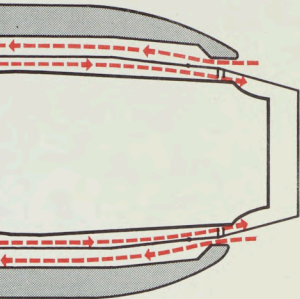
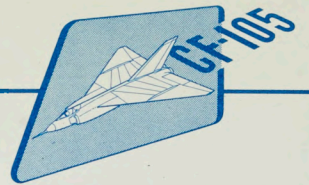

FIG. 29 ENGINE AIRFLOW AND COOL



ZONE 2

STATIC AIR COOLING & VENTILATION

APPROX. AIR FLOWS

ZONE 1 1 LB./SEC.
ZONE 2 3 LB./SEC.

50) ILATION

TO 2 LB./SEC.
TO 3 LB./SEC.

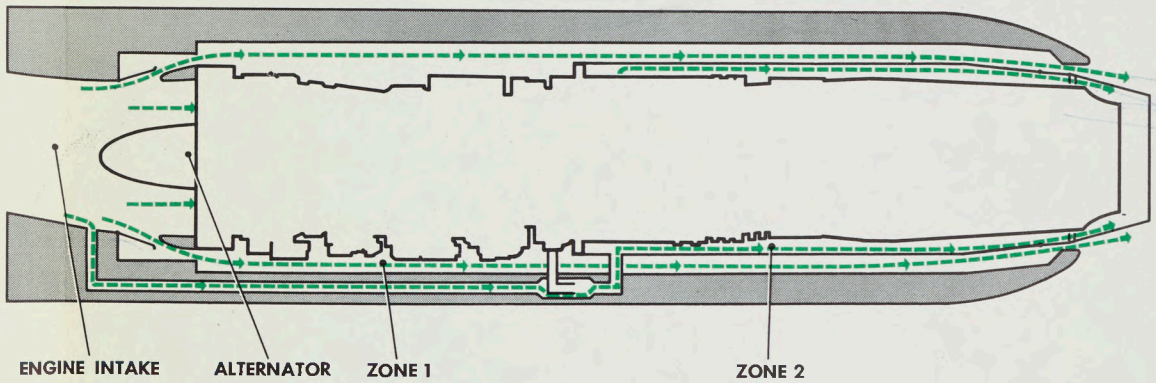

ENGINE INTAKE

ALTERNATOR

ZONE 1

ZONE 2

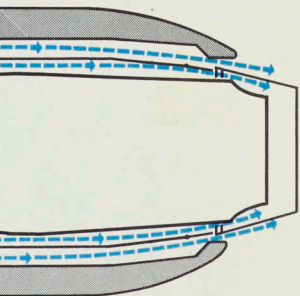

FLIGHT (M > 1.50) AIR COOLING & VENTILATION

APPROX. AIR FLOWS

ZONE 1 35 LB./SEC.
ZONE 2 3 LB./SEC.

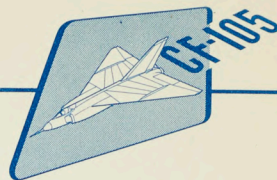

engine air bleed pressurization, simultaneously from the remainder of the left wing tanks and the aft fuselage tank through the left hand flow proportioning unit to maintain the fuel level in the left hand collector tank. The flow proportioning unit ensures that the individual rate of flow from each tributary tank is directly proportional to its capacity and that all tanks empty simultaneously, thereby minimizing the effect of change of fuel load on aircraft c.g. position. To ensure continuous transfer of fuel under normal manoeuvre conditions, the inlets to the transfer pipes are located in extreme corners of the tributary tanks and each inlet is protected by a valve which passes fuel only and not air. Fuel is transferred from the right wing tanks and the forward fuselage tank through the right hand flow proportioning unit to the right collector tank in the same manner described above for the left hand transfer system. In the event of failure of a booster pump, a by-pass pipe from the collector tank to the discharge side of the pump automatically enables the pressurized fuel to supply the appropriate engine at a reduced power. In the event of lateral fuel unbalance between left and right hand systems due to unequal engine power settings or failure of an engine, it is possible for the pilot to:-

- (a) Direct fuel from the left hand system to either or both engines.
- (b) Direct fuel from the right hand system to either or both engines.

3.12.9.2 Pumps: It is proposed to drive each booster pump mechanically by shafting from the appropriate side accessories gearbox. Mechanical drive was chosen as having distinct advantages in respect of weight, space and reliability over electrical, hydraulic, or air turbine drives.

3.12.9.3 Tanks (Internal): The number of cells and their respective capacities are as follows:-

12 integral wing tanks	15,675 lbs.
2 bladder type fuselage tanks	4,515 lbs.
	<hr style="width: 100%;"/>
Total internal fuel	20,190 lbs.
	<hr style="width: 100%;"/>

3.12.9.4 Tanks (Droppable): It is proposed to sling a single tank of 3,750 lbs. capacity (at 7.5 lbs./Imp. Gall.) from the under side of the fuselage. The tank will be quickly detachable on the ground and will be jettisonable in flight. Fuel is transferred by engine air bleed pressurization simultaneously to both right and left internal system collector tanks. Drop tank fuel is arranged to transfer before internal fuel and automatic follow-on of internal fuel transfer is accomplished:-

- (a) By making the degree of pressurization higher for drop tanks than for internal tanks.
- (b) By fitting "fuel/no air" valves to the transfer pipe inlets in the drop tank.

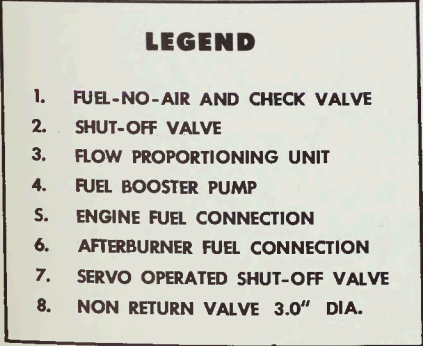
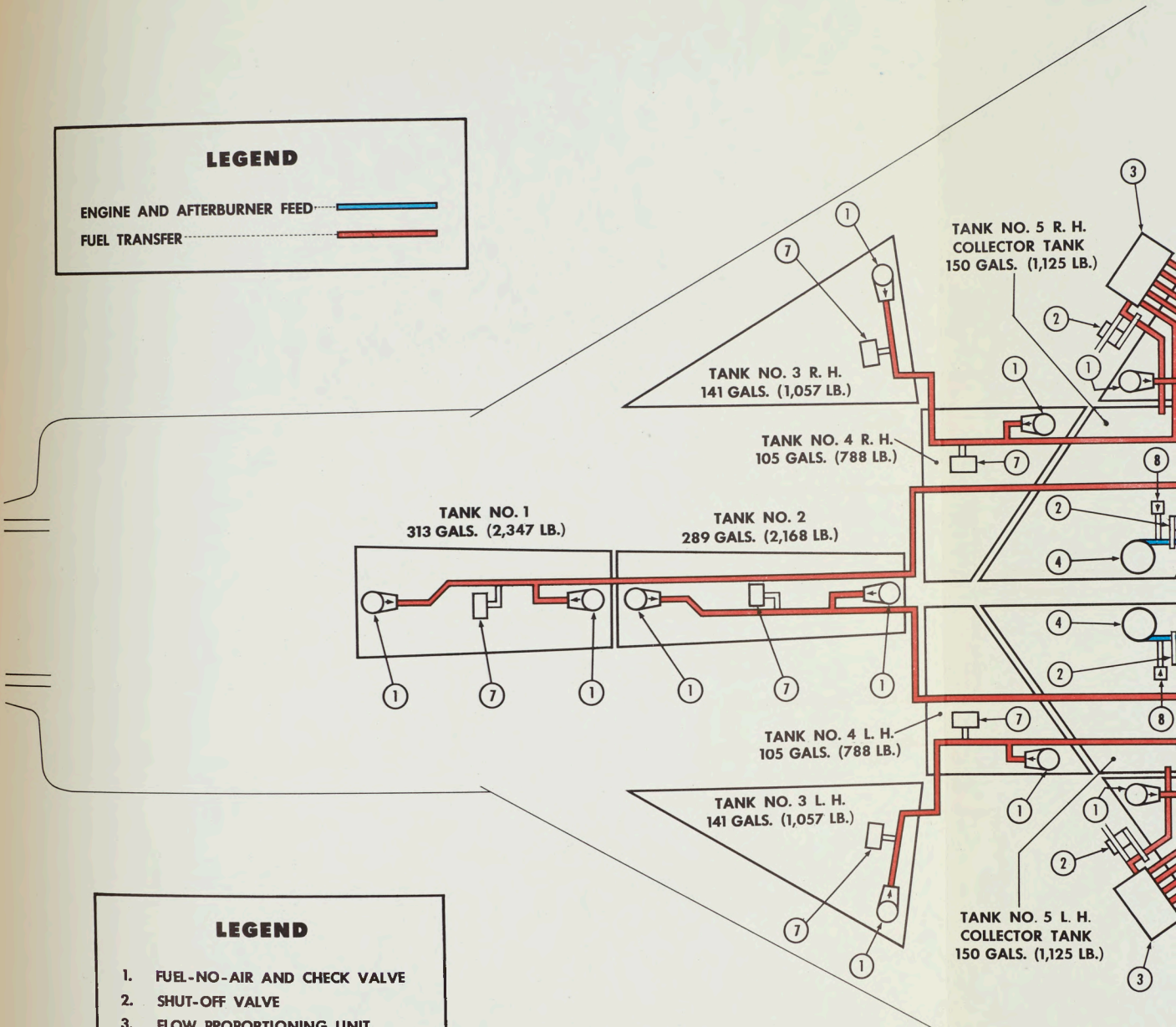
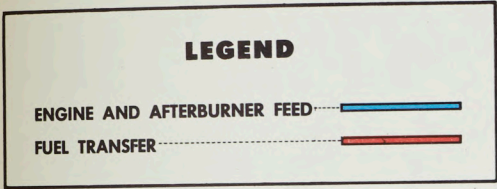

NOTE:
FUEL VOLUMES AND WEIGHTS QUOTED
ARE USABLE QUANTITIES

FIG. 30 FUEL SYSTEM - DIAGRAMMATIC OF FUEL FEED AND

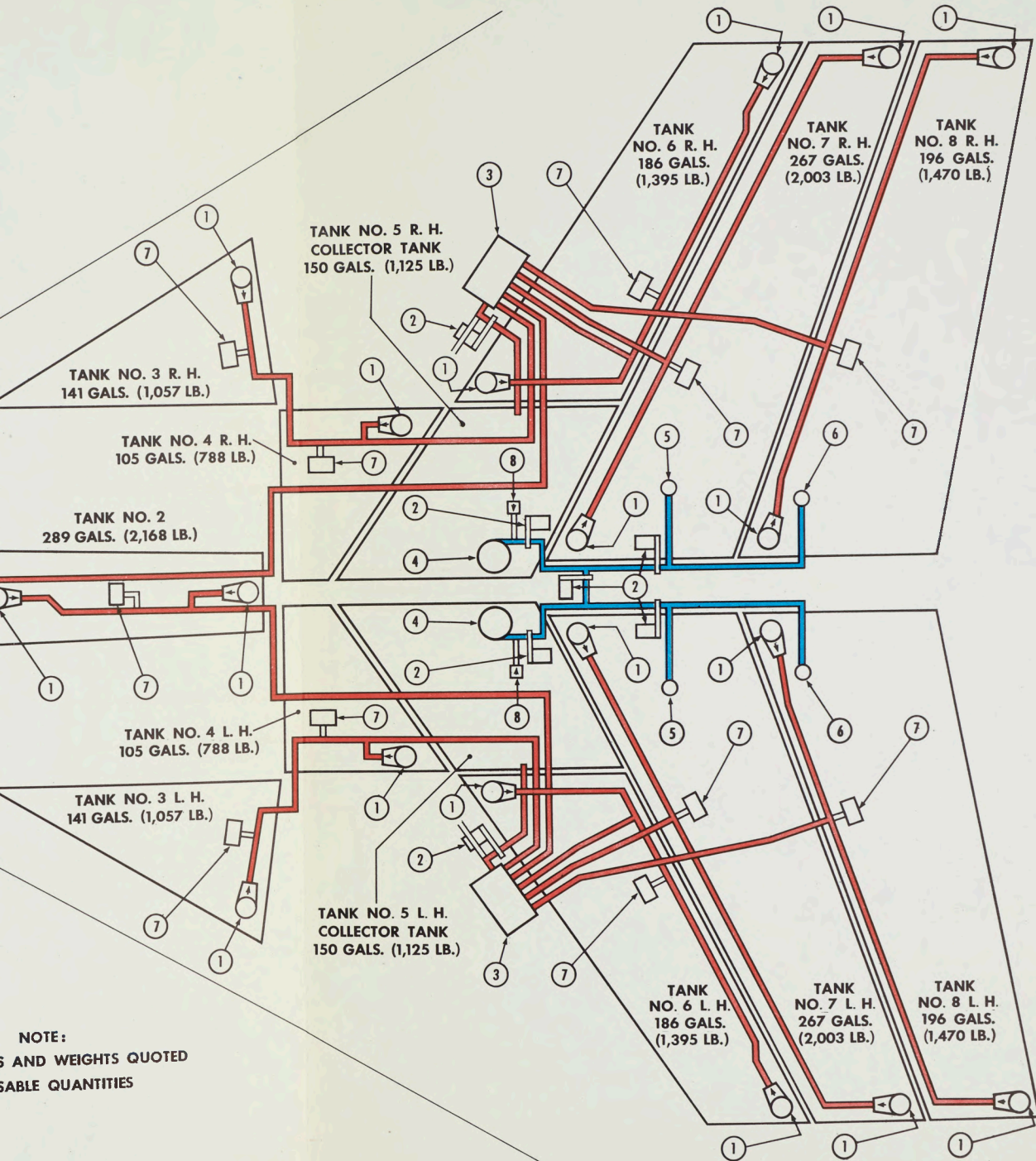
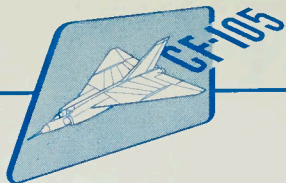

NOTE:
S AND WEIGHTS QUOTED
AS AVAILABLE QUANTITIES

FUEL SYSTEM - DIAGRAMMATIC OF FUEL FEED AND TRANSFER

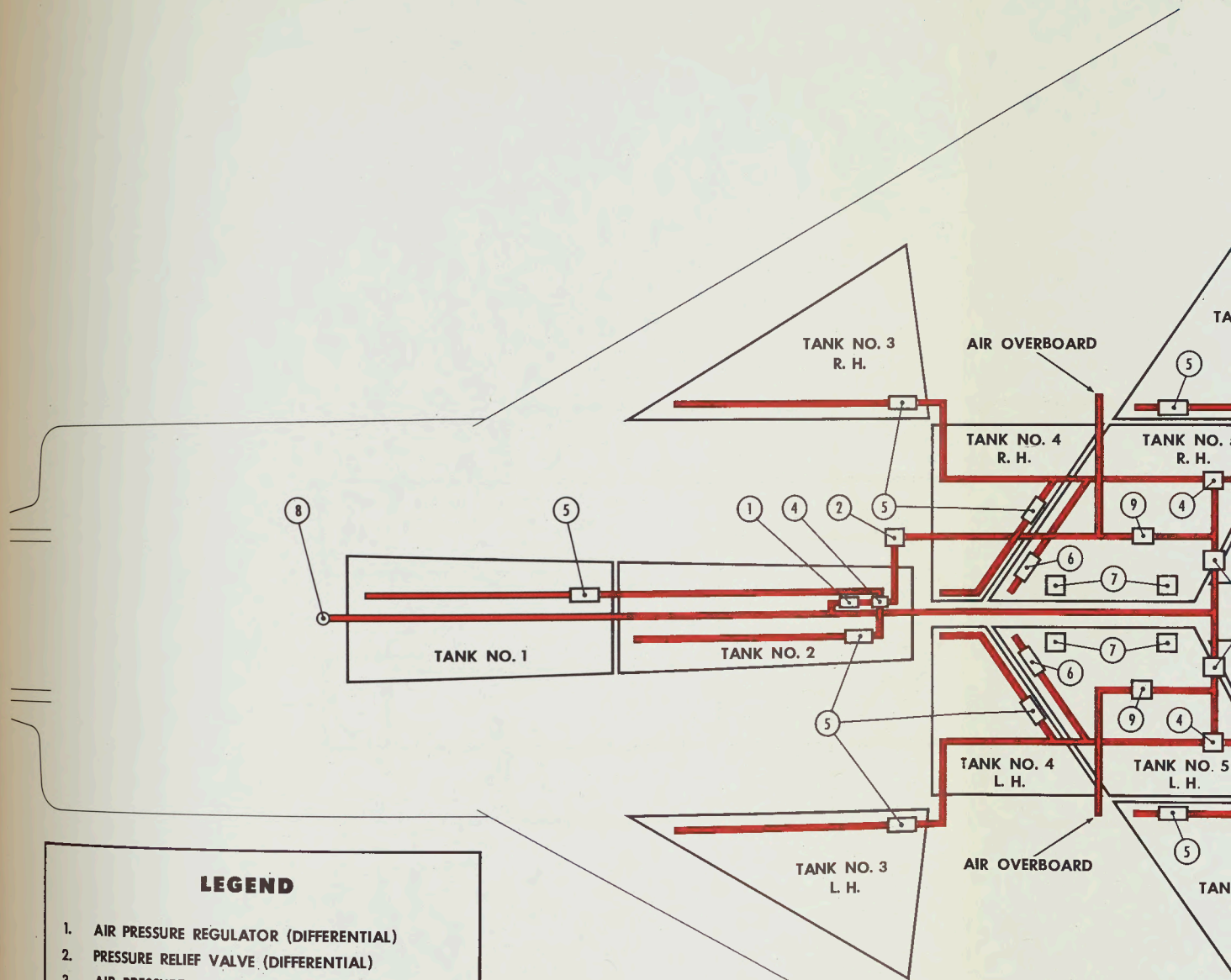

LEGEND

1. AIR PRESSURE REGULATOR (DIFFERENTIAL)
2. PRESSURE RELIEF VALVE (DIFFERENTIAL)
3. AIR PRESSURE REGULATOR (ABSOLUTE)
4. LIQUID FUEL TRAP
5. AUTOMATIC RESTRICTOR
6. NEGATIVE "G" AND LOW LEVEL AIR
ADMISSION VALVE
7. AIR RELEASE VALVE
8. CONNECTION TO AIR CONDITIONING DUCT
(DOWNSTREAM OF RAM AIR HEAT EXCHANGER)
9. PRESSURE RELIEF VALVE (ABSOLUTE)

FIG. 31 FUEL SYSTEM - DIAGRAMMATIC OF FUEL PRESSURE

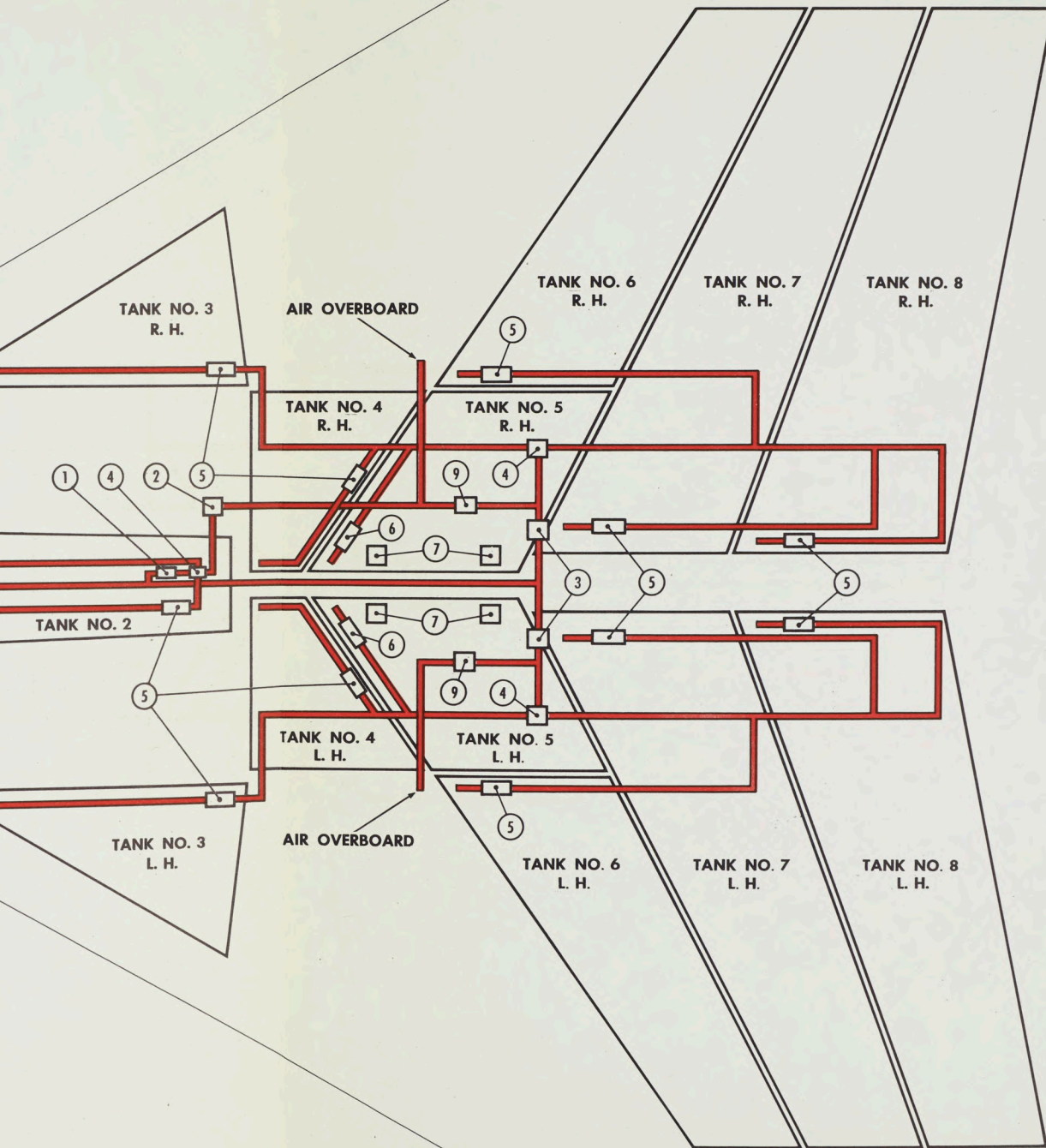

SYSTEM - DIAGRAMMATIC OF FUEL PRESSURIZATION

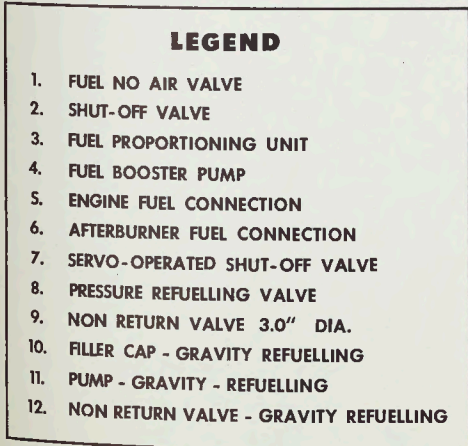
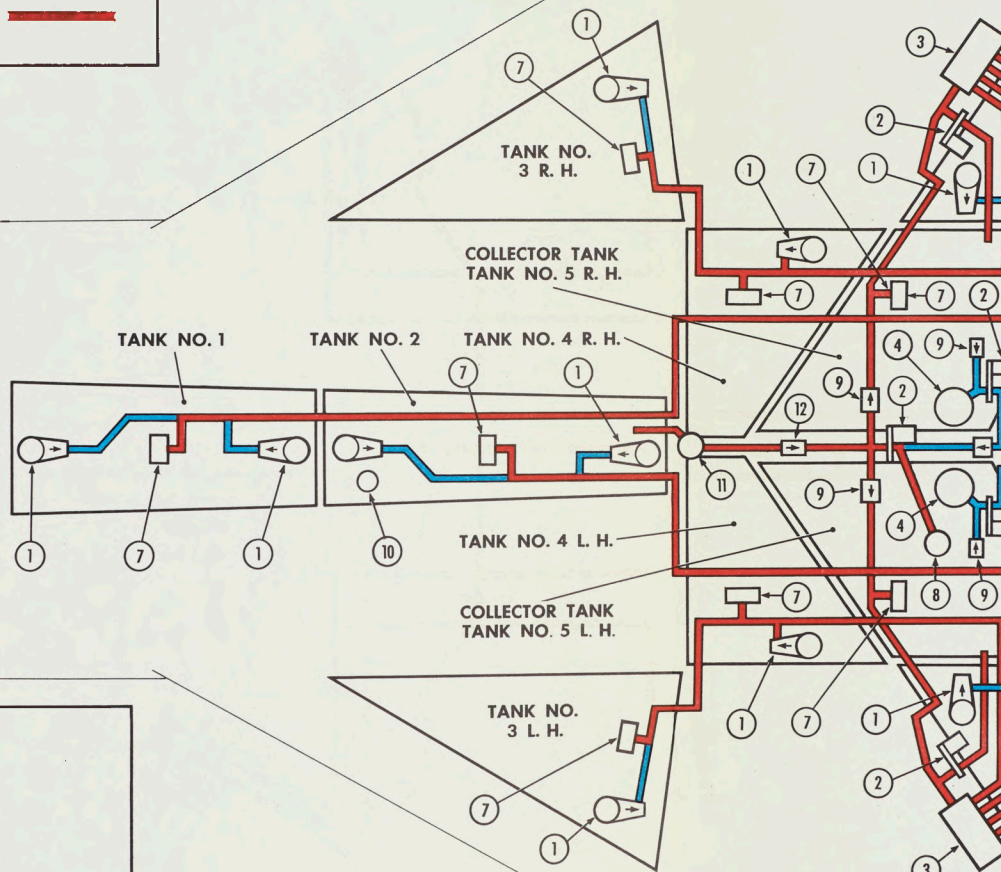
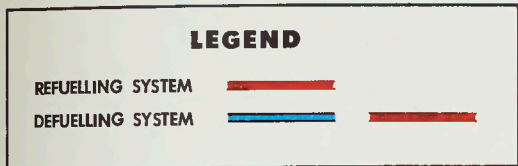
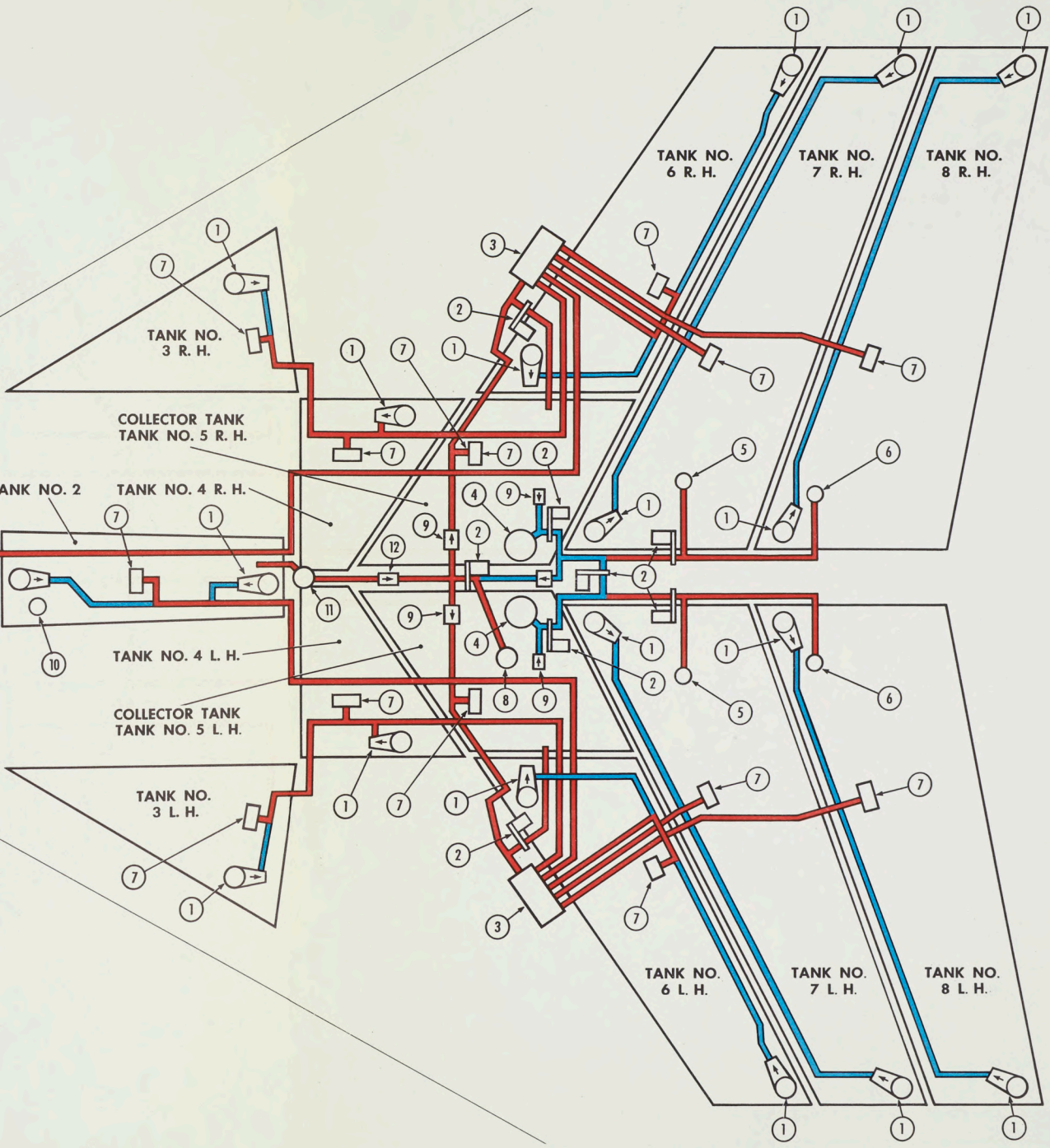
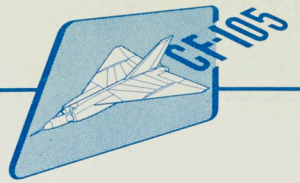
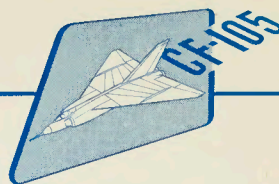

FIG. 32 FUEL SYSTEM - DIAGRAMMATIC OF REFUELLING AND DEFUELLING



FUEL SYSTEM - DIAGRAMMATIC OF REFUELLING AND DEFUELLING



- 3.12.9.5 Vent System: Wing tanks are pressurized to an absolute value and do not vent to atmosphere. Fuselage tanks are pressurized to a differential value and outwardly vent through a relief valve to atmosphere. There is no inwards relief of fuselage tanks from atmosphere because of pressurization. The collector tanks incorporate valves which vent only accumulated air to atmosphere, subject to the collector tank pressure being greater than the pressure required to prevent fuel boiling.
- 3.12.9.6 Piping and Fittings: Refer to Figs. 30, 31 and 32, which show the proposed layout.
- 3.12.9.7 Valves: Refer to Figs. 30, 31 and 32, which show the main valves required in the fuel system.
- 3.12.9.8 Strainers and Filters: An adequate number of these will be incorporated in the system.
- 3.12.9.9 Quantity Gauges and Flowmeters: Quantity gauges are of the capacitance type with fuel contents presented to the pilot on two indicators, one for each of the left hand and right hand fuel systems. Flowmeters will not be fitted.
- 3.12.9.10 Drainage Provisions: These will be dealt with adequately in the design of the system.
- 3.12.9.11 Fuel Vapour Inertion: Whether an inertion system will be incorporated depends on RCAF requirements in this respect.
- 3.12.9.12 Fuel Evaporation Control: The degree of pressurization for all fuel tanks is sufficient not only to transfer fuel, but to prevent fuel from boiling.
- 3.12.9.13 Refuelling Provisions: Ground refuelling will be carried out from a single point pressure refuelling adaptor. Flow valves will be provided in the tanks to automatically shut-off the fuel when the tank is filled to capacity. Over-riding control is supplied to stop refuelling at any desired partial fuel load, partial refuelling being effected through the flow proportioning units in order to achieve the correct aircraft c. g. balance by filling each tank to the same proportion of its total capacity. Provision for in-flight refuelling is not incorporated in this aircraft.
- 3.12.9.14 Defuelling Provisions: Ground defuelling may be carried out from the same single point adaptor as is used for refuelling.
- 3.12.10 Water Injection System: This is not fitted on this airplane.
- 3.12.11 Propulsion System Controls: The design of this system is in abeyance until the engine manufacturer has decided upon the type of control to be used for the infinitely variable afterburner nozzle.

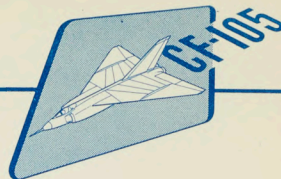

3.12.12 Starting System: Two systems are under consideration:-

- (a) A ground supplied air turbine starter
- (b) A self contained air-fuel starter

The final decision as to which system will be used has not yet been made.

3.12.13 Propeller: Not applicable.

3.12.14 Rocket Propulsion System: This is not required on this airplane.

3.13 Auxiliary Powerplant: This is not required on this airplane.

3.14 Instruments and Navigational Equipment:

3.14.1 Instruments: The instruments which will be fitted in the cockpits comprise the following:-

- (a) The normal engine and aircraft services instruments.
- (b) Such flight instruments as are required to satisfactorily fly and land the airplane in the event of failure of the MX. 1179 or MG-3 electronic equipment.

3.14.2 Navigational Equipment: This equipment is included in the MG-3 and MX. 1179 electronic systems as described elsewhere in this brochure.

3.14.3 Installation: The installation of instruments and equipment will comply with RCAF requirements and specifications.

3.15 Hydraulic, Emergency Air and Pneumatic Systems:

3.15.1 Hydraulic and Emergency Air Systems:

3.15.1.1 Hydraulic System: The aircraft flying controls are operated by two separate hydraulic systems, and the utility and armament circuits by a third system. All systems have separate reservoirs and ground charging points. The systems are designed generally in accordance with MIL-H-5440 requirements. Standard hydraulic fluid, MIL-O-5606 and standard AN type fittings are used. Pressure lines are of one-eighth hard stainless steel and return lines are aluminum alloy. The flying control systems and armament operate at a rated pressure of 4000 p. s. i. and the utility system at a rated pressure of 3000 p. s. i. All pumps are driven from engine driven gearboxes.

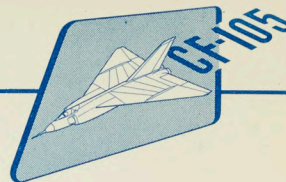

3.15.1.1.1 Flying Control System:

3.15.1.1.1.1 No. 1 Flying Control System: (Refer to Fig. 33) The No. 1 flying control system comprises a power circuit consisting of two variable delivery hydraulic pumps, each mounted on one pad of two dual pad gearboxes, one of which is driven by each engine. The two pumps are supplied by a single airless type pressurized reservoir, the fluid passing through a fuel heat exchanger, located in the suction line to maintain a maximum system temperature of 250°F. Delivery from the pumps passes through check valves and filters into a common pressure line in which is located an accumulator and a relief valve.

3.15.1.1.1.2 No. 2 Flying Control and Speed Brake System: (Refer to Fig. 33) The No. 2 flying control system has an identical power circuit to the No. 1 system, the pumps being located on the other pads of the dual gearboxes, one pump being driven from each engine. The No. 2 system supplies pressure to the other half of the dual valves and actuators to give half the total hinge moment required. In the event of failure of the No. 1 system pressure, the No. 2 system will be unaffected and will operate the controls normally and give up to half the rated output. In addition to the surface control units, the No. 2 system supplies pressure to the speed brake circuit, which consists of two actuators and servo valves which are controlled by a cockpit lever and give infinite positioning range.

3.15.1.1.2 Utility Circuit: The utility power circuit comprises a single variable volume pump, pressurized reservoir and relief valve. The services actuated are the landing gear, armament, brakes and steering. An automatic depressurizing valve permits the pump pressure to by-pass to the reservoir when there is no demand from any service. A reducing valve maintains the maximum pressure in the landing gear circuit at 3,000 p. s. i.

3.15.1.1.2.1 Landing Gear Circuit: The landing gear circuit actuates the two main landing gear doors, main landing gear legs and nose landing gear leg. A solenoid operated open center 4-way control valve directs fluid to the up or down circuit as selected from the cockpit lever. A "down" selection directs the fluid to the main gear door up locks and door jacks. On the final down travel of the two main door jacks, mechanical valves are opened. These valves are cross-coupled in such a manner that both must be open before pressure fluid is admitted to the main gear uplocks and extension portion of the actuators. The main legs are locked down by separate down locks. On the final movement of the main gear, mechanically sequenced valves, which block the retraction side of each door actuator are closed. "Up" selection directs fluid from the solenoid control valve to the main gear down locks and retraction portions of the main nose actuator. On retraction of the legs, the mechanical sequence valves are opened admitting fluid into the retraction portion of the main door actuators.

3.15.1.1.2.2 Armament Circuit: In the case of the "Falcon" missile installation, the armament circuit consists of eight missile launching actuators energized by two self-displacing accumulators. Each actuator has a servo control valve integral with

LEGEND

- | | |
|---------------------------------|-----------------------------|
| 1. PUMP | 9. ELEVATOR ACTUATOR |
| 2. GROUND CONNECTION - SUCTION | 10. AILERON ACTUATOR |
| 3. GROUND CONNECTION - PRESSURE | 11. RUDDER ACTUATOR |
| 4. FILTER - H. P. | 12. ELEVATOR PARALLEL SERVO |
| 5. RESERVOIR | 13. AILERON PARALLEL SERVO |
| 6. HEAT EXCHANGER | 14. DAMPER SERVO |
| 7. ACCUMULATOR | 15. SPEED BREAK ACTUATOR |
| 8. PRESSURE REDUCING VALVE | 16. PRESSURE RELIEF VALVE |

↑ CHECK VALVE

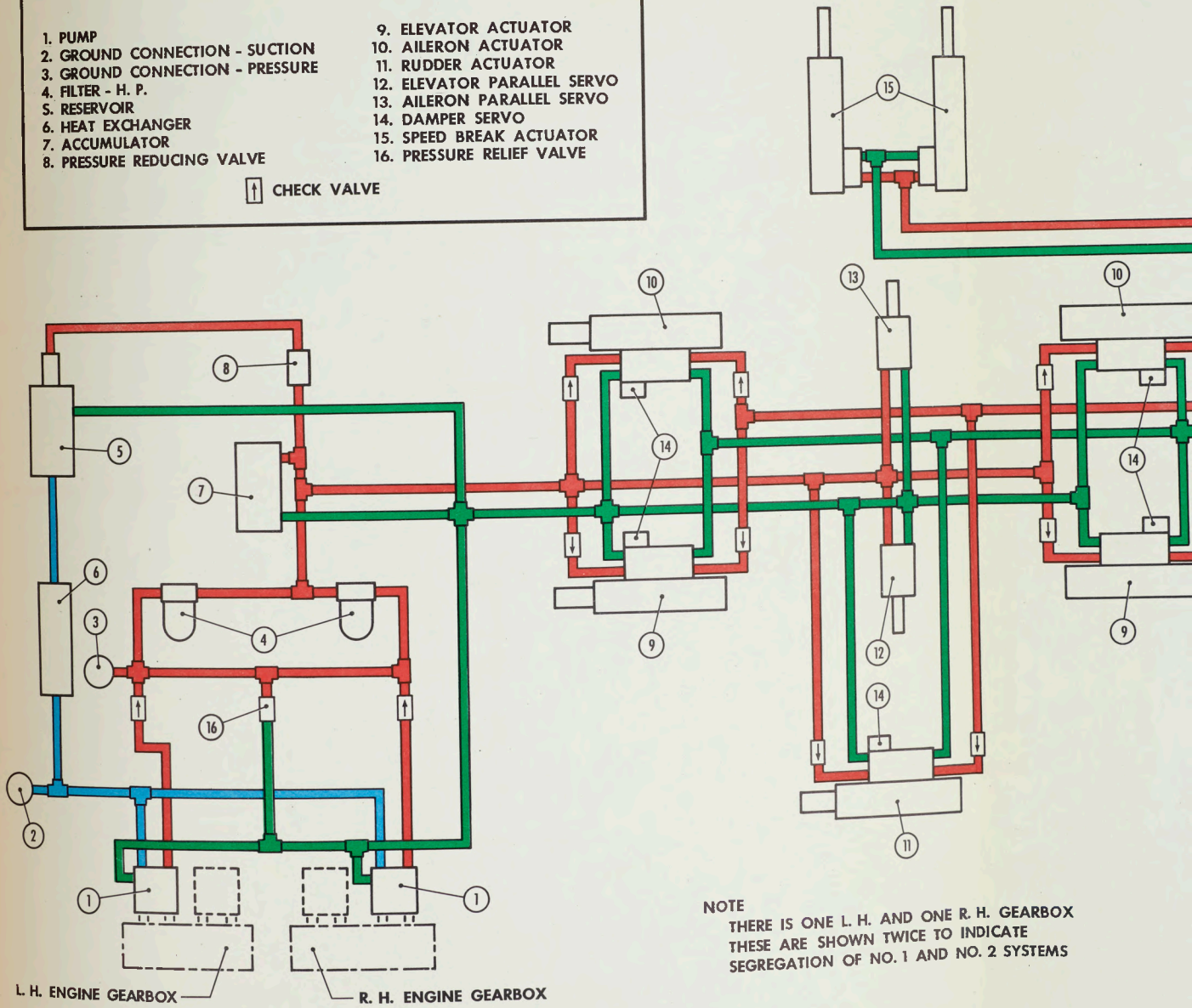

NOTE
 THERE IS ONE L. H. AND ONE R. H. GEARBOX
 THESE ARE SHOWN TWICE TO INDICATE
 SEGREGATION OF NO. 1 AND NO. 2 SYSTEMS

FLYING CONTROLS NO. 1 SYSTEM

FIG. 33 HYDRAULICS SCHEMATIC FLYING CONTROL

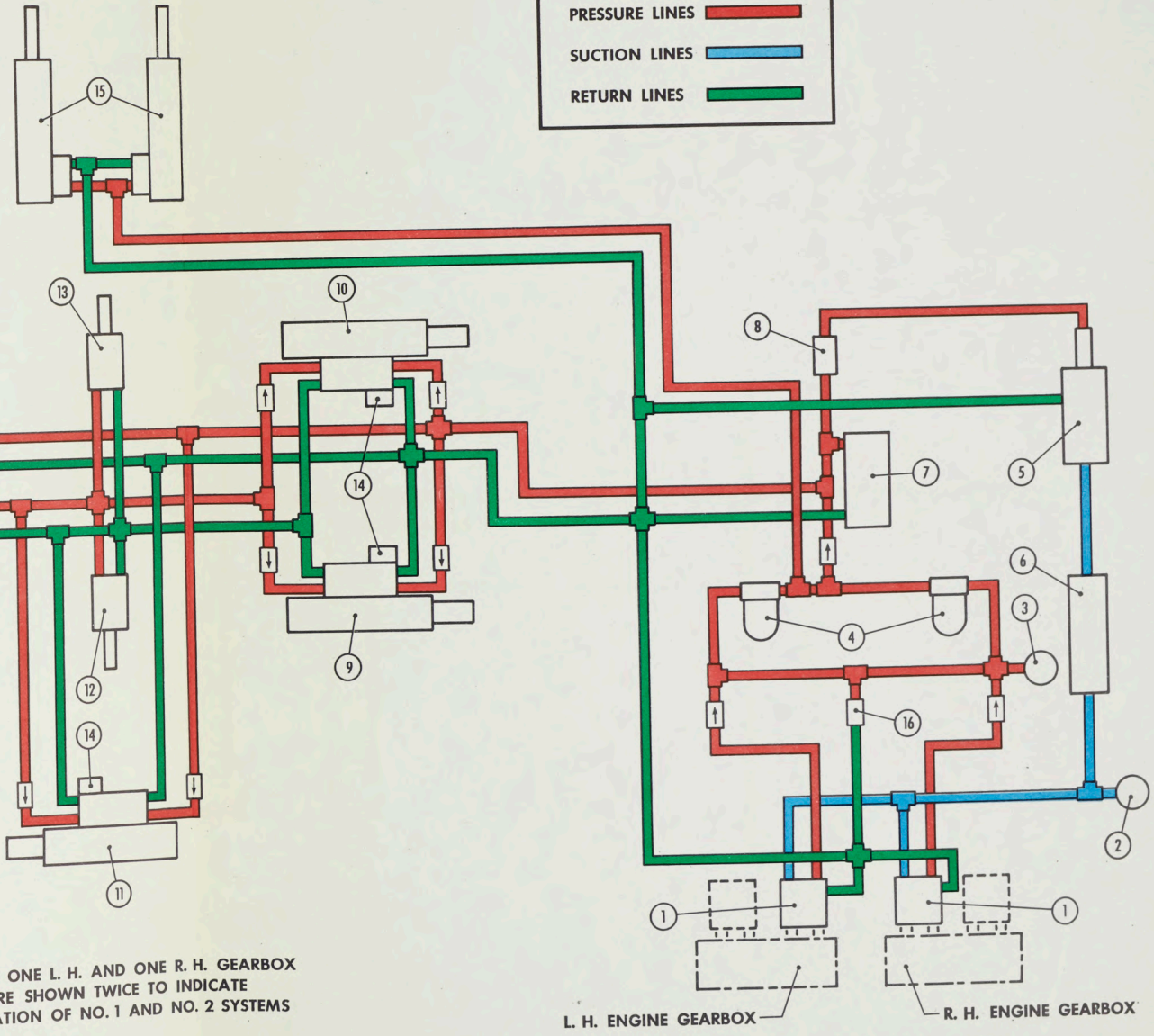
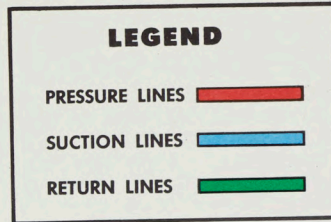
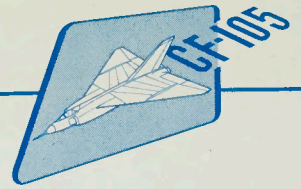

NOTE
 THERE IS ONE L. H. AND ONE R. H. GEARBOX
 THESE ARE SHOWN TWICE TO INDICATE
 SEGREGATION OF NO. 1 AND NO. 2 SYSTEMS

L. H. ENGINE GEARBOX — R. H. ENGINE GEARBOX
 FLYING CONTROLS NO. 2 SYSTEM

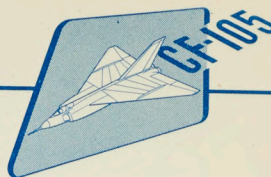
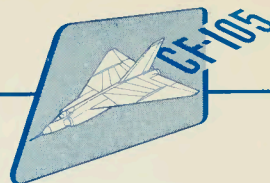

FIG. 34 HYDRAULICS SCHEMATIC UTILITY SYSTEM

(to be issued later)



it, operated by programming electro-mechanical input. The armament system will be coupled to the main utility system through quick disconnect fittings.

3.15.1.1.2.3 Brake System: Two main power brake control valves are actuated through a linkage system to the pilot's foot pedals. Pressure to the brake valves is fed through a reducing valve to maintain the maximum pressure at 1500 p. s. i. An accumulator supplies fluid for sufficient brake operations for a single stop in the event of failure of the main pressure source. Anti-skid units are located at each wheel.

3.15.1.1.2.4 Steering and Anti-Shimmy Circuit: The steering cylinder is attached to the nose leg and is spring-centered, acting also as a shimmy damper. Steering is effected through a mechanical linkage, and a control valve and follow-up mechanism on the leg. A solenoid-operated stop valve is energized and supplies pressure to the control valve. This admits fluid to the desired side of the steering cylinder. A relief valve is fitted which admits fluid from one side of the cylinder to the other when a pressure build-up is caused through excessive turning loads.

3.15.1.2 Emergency Air System: The emergency air system comprises an emergency air bottle and manually operated valve actuated by the cockpit under-carriage lever. Air enters the main down lines system through a shuttle valve, and fluid from the retraction side of the circuit is directed to the return lines through a jettison valve.

3.15.2 Pneumatic System:

3.15.2.1 Description and Components: A low pressure pneumatic system will be fitted, operating at a maximum pressure of 200 p. s. i. In flight, air will be supplied from both main engine compressors. On the ground, the system will operate from an external source of compressed air. Following is a list of the services operated by the system and their function:

(a) Air Conditioning system to:

- (1) Control cockpit temperature and pressure.
- (2) Supply cooling air to electronic equipment.
- (3) Control armament bay temperature.
- (4) Cool miscellaneous equipment.

(b) Engine starting: An air turbine motor is fitted to each engine for starting.

(c) Fuel tank pressurization: Fuel tank pressure is maintained by bleed air.

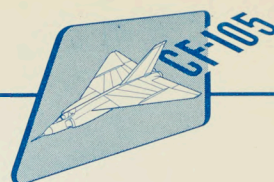

- (d) Miscellaneous: In addition to the aforementioned main systems air will be supplied for various items such as anti "G" valves, canopy seal, etc.

The design of ducting and associated fittings will, in general, follow ARDCM 80-1. A schematic of the system is given in Fig. 35.

3.15.2.2 General Functioning: Air supply for the system is from both engines through non-return valves, so that it may be operated from either or both engines. Compressed air from an external source can be connected to the system through a quick disconnect. Air to the various systems is controlled by means of shut-off, pressure reducing and flow control valves, depending on the requirement of the system. The temperature of air required for air conditioning is reduced by means of an air-to-air heat exchanger and an expansion turbine and proportioned to the various compartments as required. Additional cooling is supplied by evaporating water.

3.16 Electrical:

3.16.1 Description: All electrical power, except that from the batteries, is generated by two 40 k. v. a., 400 cycle alternators. Each alternator is driven by an engine mounted constant-speed drive. This arrangement ensures that the alternator power output is of a constant frequency. The composite system supplies various voltages (i. e. 28.5v., 115v., 200v. and higher) for supply to the items of radar equipment. Direct current is obtained from rectifiers connected to the 26v. a. c. bus. The battery is connected in parallel with the 28v. d. c. bus for initial power requirements. A circuit diagram of the system is shown in Fig. 36.

ELECTRICAL SERVICES

A LIGHTING

- Taxi
- Downward Ident
- Navigation
- Front Cockpit
- Rear Cockpit
- Equipment Bay
- Emergency Cockpit Floodlight

B INSTRUMENTS

- Turn and Bank
- Artificial Horizon
- Outside Air Temp
- Ice Warning, Airframe

- Heated Pressure Heads
- Lighting

C FLYING CONTROLS

- Hydraulic Pressure Flight Control
- Warning Light
- Speed Brake Actuation
- Elevator, Rudder and Aileron Trim
- Landing Gear Actuation and
- Warning
- Landing Gear Indication
- Nose Wheel Steering
- Hydraulic Pressure Warning
- Light

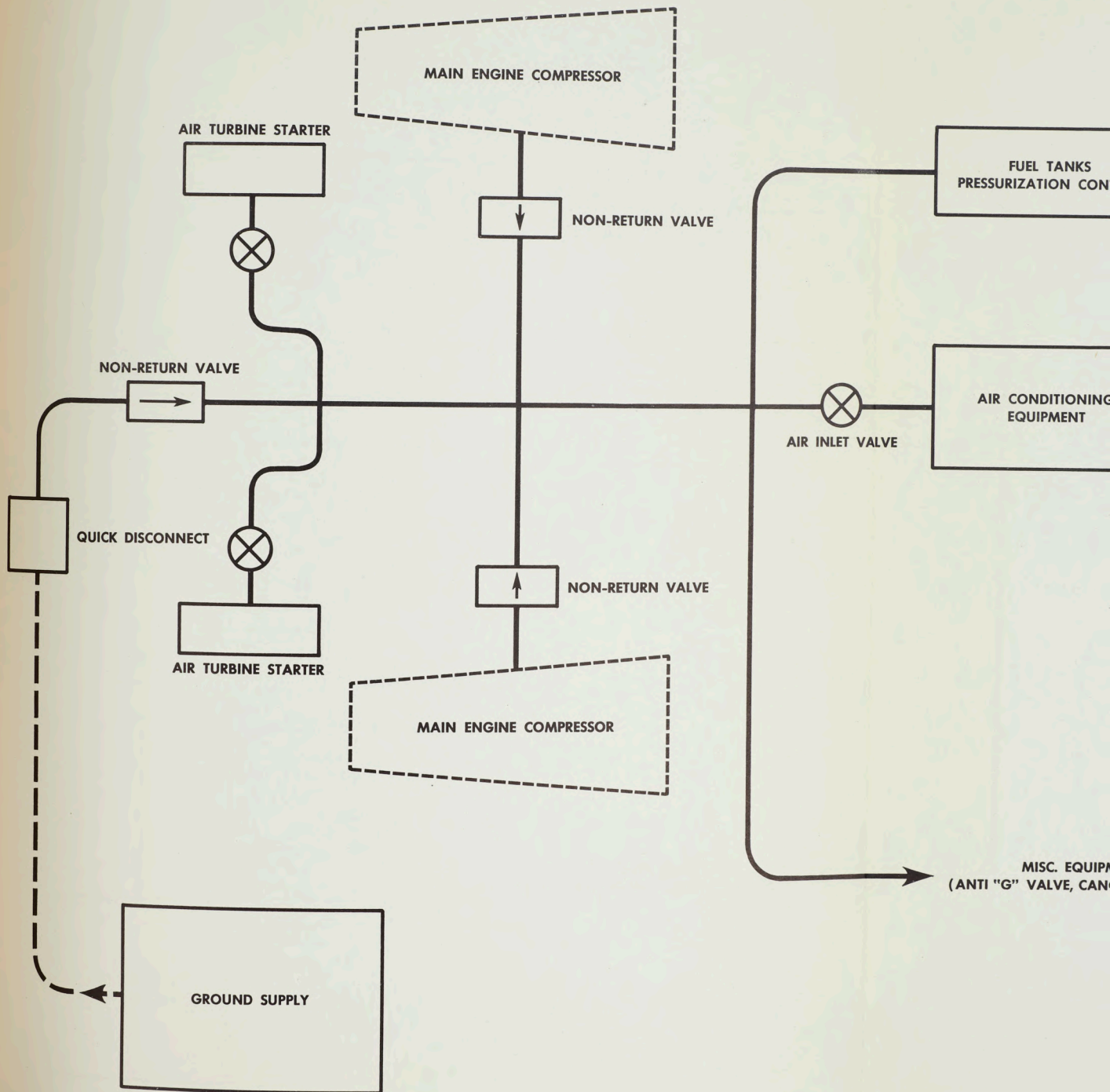
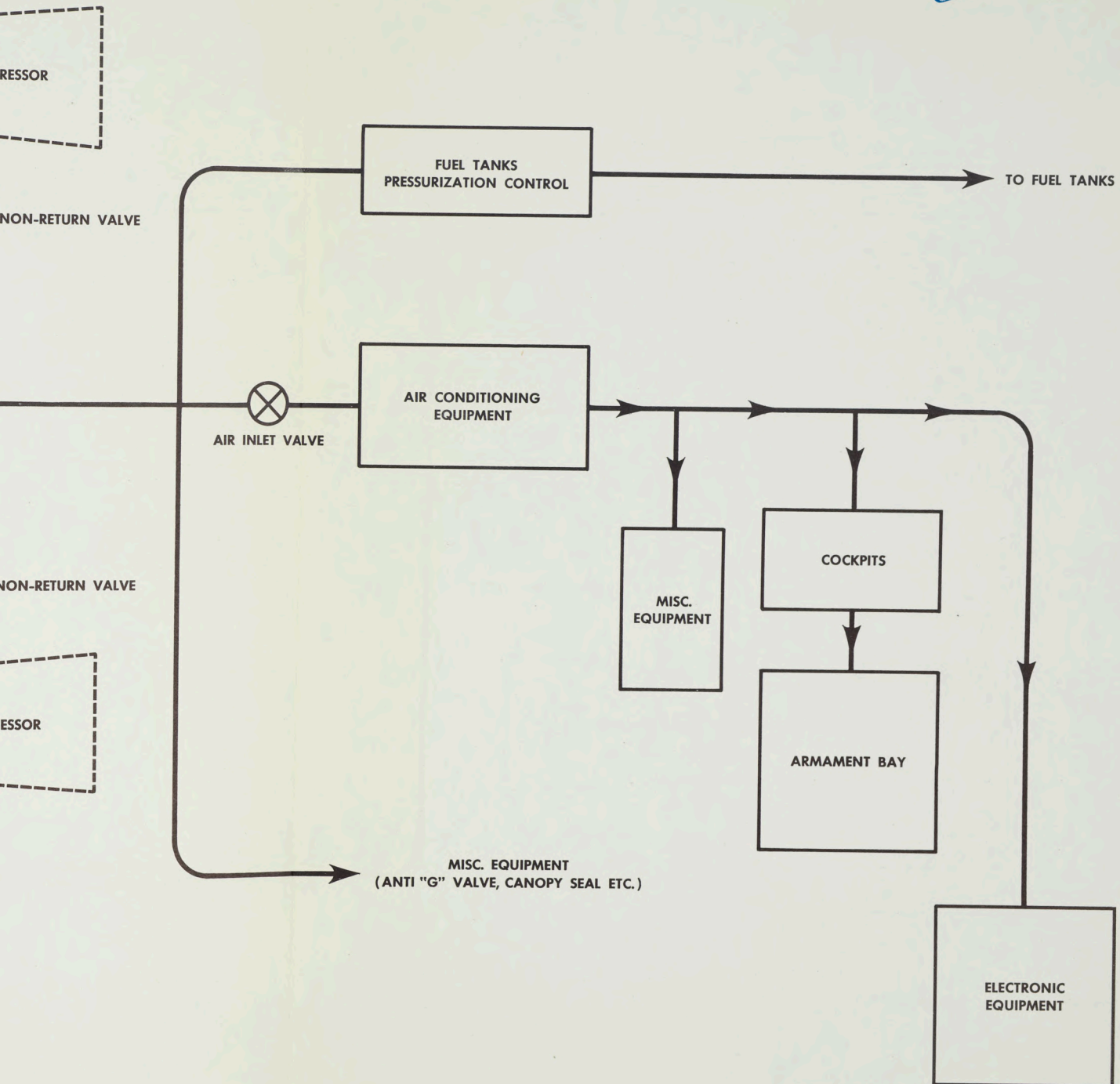
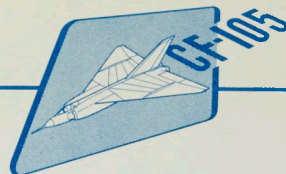

FIG. 35 LOW PRESSURE PNEUMATIC SYSTEM SCHEMA



35 LOW PRESSURE PNEUMATIC SYSTEM SCHEMATIC

LEGEND

- (1) 40 k. v. a. - 115/200v., 400 Cycle
a. c. Alternator.
- (2) Alternator Control Panel.
- (3) Alternator Transformer Relays.
- (4) Selenium Rectifiers and Transformers.
- (5) 24 v. 9-26 A.H. Battery.
- (6) External Supply Socket - 400 Cycle.
- (7) 28.5 v. \pm 1 v. d.c. Bus Bar.
- (8) Alternator Switches.
- (9) Electronic Transformer Relay.
- (10) Electrical Monitor Load Relay.
- (11) Alternator Regulators.

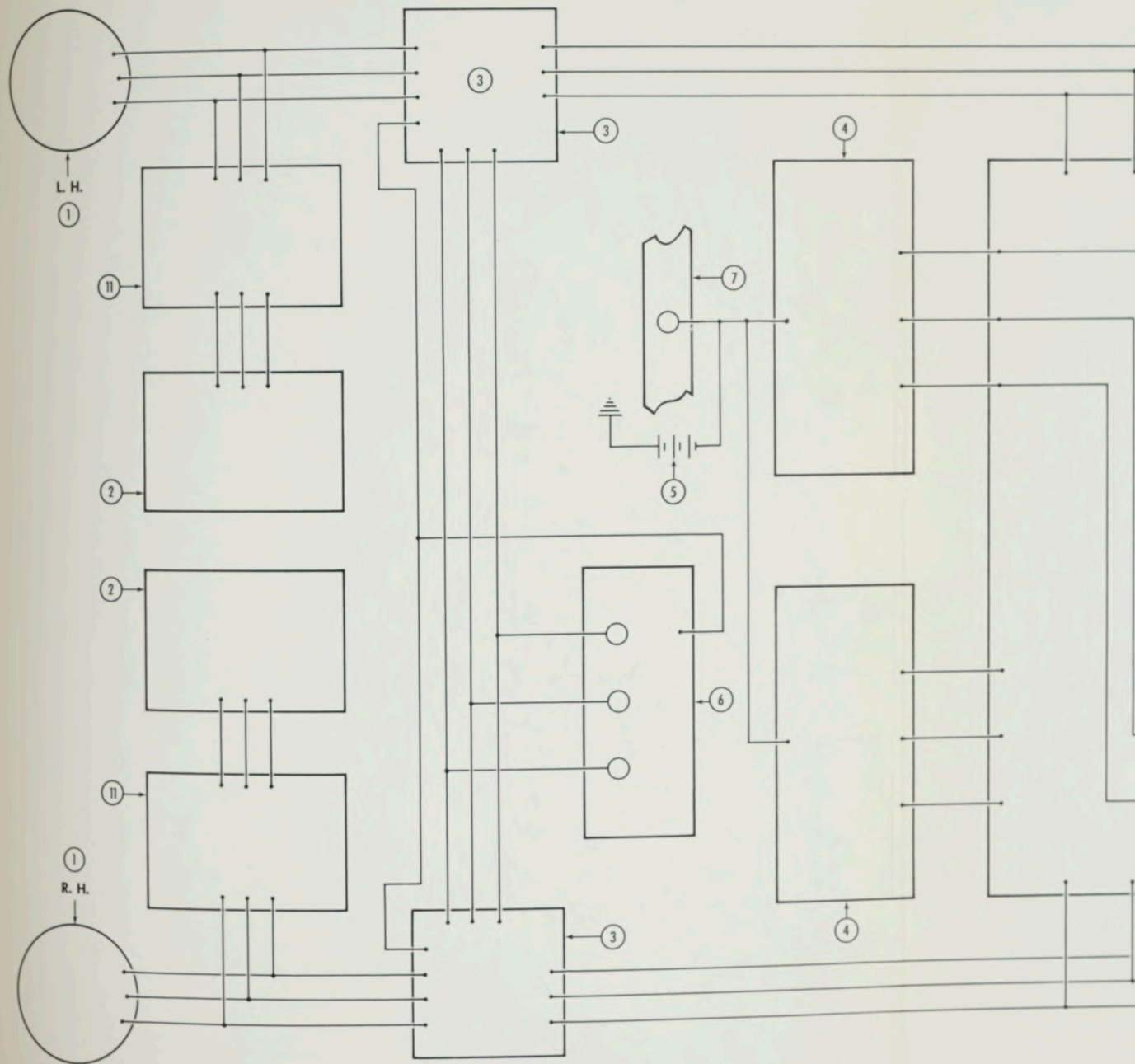

FIG. 36 ELECTRICS CIRCUIT DIAGRAM

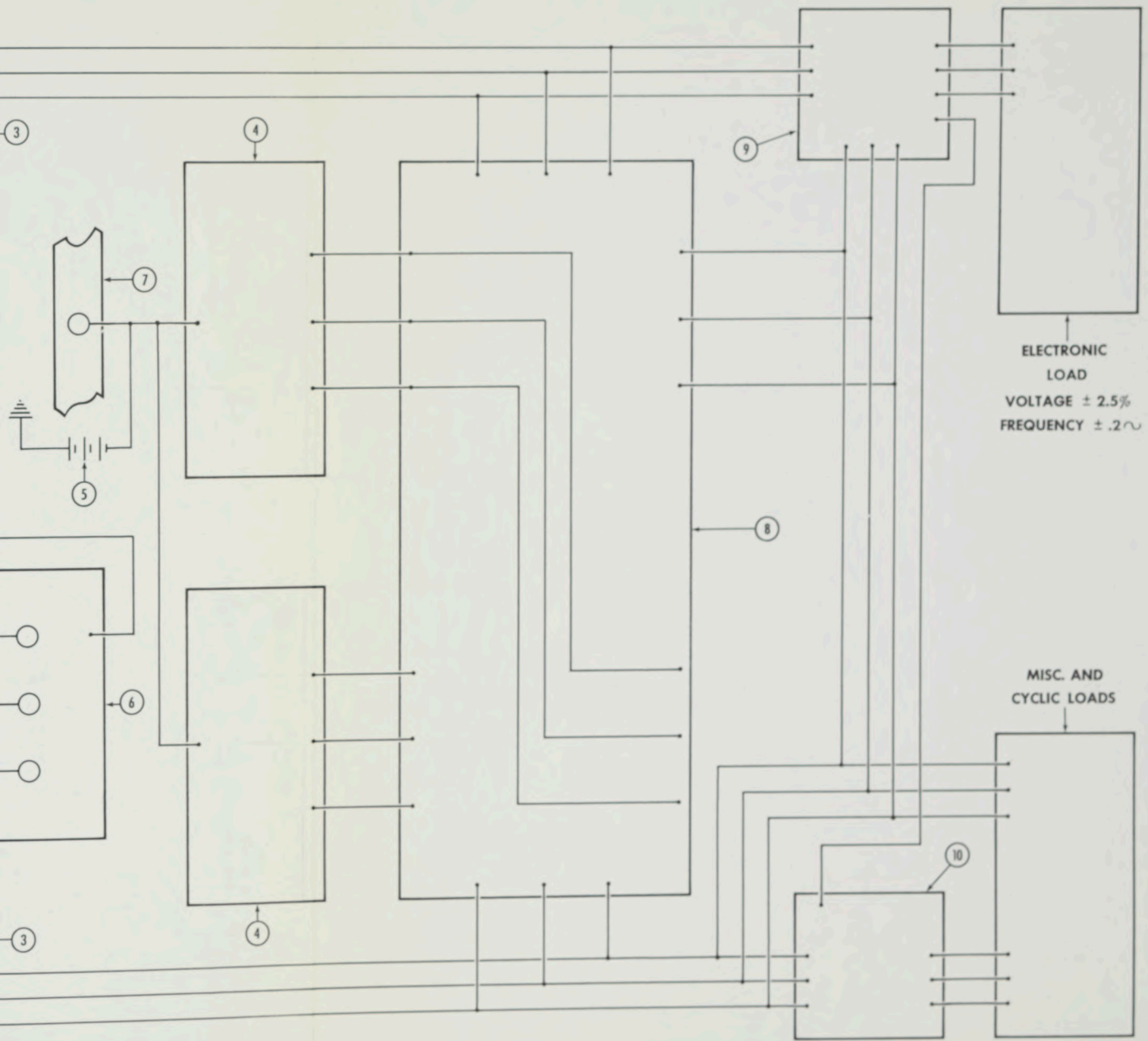
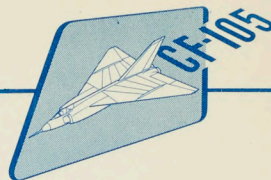

FIG. 36 ELECTRICS CIRCUIT DIAGRAM



D ENGINE INSTRUMENTS

- Starting and Ignition
- Engine Relight
- Low Pressure Tachometer
- Oil Pressure Warning Light
- Inlet Oil Temp
- Turbine Entry Temp
- Bearing Temp
- Engine Anti-Icing
- Engine De-Icing
- Engine Ice Detection
- Engine Afterburner and Controls
- Fire Detection
- Fire Extinguisher

E FUEL SYSTEM

- Fuel Crossfeed Control
- Fuel Contents Indication
- Low Level Fuel Warning
 - Light and F.P.U. By-pass
- Low Pressure Fuel Cocks
- External Fuel Tank Jettison
- Ground Refuelling and Defuelling

F AIR CONDITIONING

- Air Conditioning System
- Cockpits

- Air Conditioning System
- Armament Bay
- Cabin Pressure Warning
- Cockpit Heating

G ARMAMENT

- Missiles

H ELECTRONICS

- Radio and Radar

I ENGINE

- Hydraulic Pressure Warning
 - Light
- Afterburner Emergency
 - Switch
- Hydraulic Emergency Switch
- Fuel Control Emergency
 - Warning Light
- Primary Pump Warning
 - Light
- Engine Fuel Control Selector

J MISCELLANEOUS

- Windscreen De-Icing and
 - De-Misting
- Tail Parachute Actuation

3.16.2 Electrical Power Supply: The electrical load to be supplied by the alternators is as follows:-

	<u>Supply</u>	<u>Demand</u>
Electronics	5 k. v. a.
Electrics including fuel pumps	16.54 k. v. a.
Armament and Fire Control	7.5 k. v. a.
Missiles	7.2 k. v. a.

In the event of failure of an alternator the remaining one will carry partial load for any length of time. The normal load will be approximately 36.5 k. v. a. A control panel for each alternator is provided in the cockpit. The branch circuit breakers are located in the nose wheel well and aft of station 495.

Good voltage regulation is obtained by using compound feedback. Provision is also made in the power circuit for over-voltage protection, feeder protection, reverse current protection, faulty alternator disconnection and load equalization. The emergency systems are the main load on the battery. An external supply is provided for the a. c. system only. Ground power is obtained by supplying air to

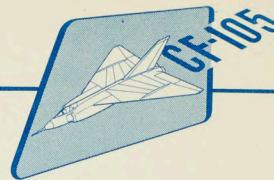

the cooling system of the alternator control equipment while receiving power from external alternators. Danger of alternator and equipment overheating is obviated by the circulation of cooling air supplied by the external pneumatic system.

3.16.3 Electrical Power Conversion: Some d. c. power is required and is obtained from selenium rectifiers connected to the 28.5v. a. c. bus. These units are cooled by the air conditioning system.

3.16.4 Equipment - Installation: The alternators are installed on the nose bullet of the engine. Removal of the alternators can be accomplished through the intake tunnel. The alternator control panels and rectifier units are located aft of station 485. Access is gained to these latter components by an access door on the under-side of the fuselage. The battery is located in the nose wheel well giving ease of access for inspection and servicing. The alternator switches are located in, and are accessible from, the cockpit.

3.16.5 Wiring: Wiring will be fitted in accordance with Spec. MIL-W-7139A.

3.16.6 Bonding: All flying controls, moving surfaces, electrical panels and junction boxes will be bonded to the main structure in accordance with the instructions issued in Spec. MIL-B-5087.

3.16.7 Controls: Trip free circuit breakers will be used on d. c. circuits and some a. c. circuits located in +160°F or lower ambient zones. Fuses will be used on other a. c. circuits. Current limiters will be used in the power distribution and branch feeder circuits in ambients above +160°F.

3.16.8 Lighting: Lighting will be provided for the following:-

- | | |
|---------------------------------|-----------------------------|
| (a) Cockpit and instrumentation | (c) Navigation, and |
| (b) Taxi | (d) Downward identification |

3.16.9 Starting and Ignition: (Refer to para. 3.12.12).

3.16.10 Receptacles: An external power receptacle supplies the 200/115v. a. c., 400 cycle 3 phase supply only. Special AN connectors will be used on all junction boxes and panels. Provision will be made for fuel line grounding and a cable will be fitted to ground the fuselage structure.

3.16.11 Indicators: For details of the electrical indicators refer to sub-paragraph

3.16.1. Warning lamps are provided for:-

- (a) Ice warning
- (b) Fire detection, and
- (c) Fuel pressure warning

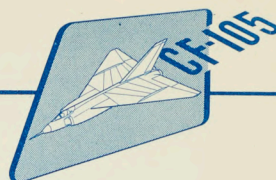

3.16.12 Electrical Drives: Not used in this airplane.

3.16.13 Relays: Relays will be used in the following circuits:-

- (a) High power
- (b) Alternator control, and
- (c) Battery

3.16.14 Booster Coil: Not used in this airplane.

3.16.15 Radio Filters: These items will be incorporated as required.

3.17 Electronics:

3.17.1 Description: Provision is made in the CF-105 to accommodate an integrated interceptor system based on a digital computer, such as the Hughes MX.1179 equipment. Such an integrated system would include facilities for automatic navigation, interception, attack, return to base and automatic landing.

Because the time phasing of the CF-105 is earlier than the anticipated availability of the digital computing system, the electronic installations have been designed to accomplish essentially the same objective using sub-systems based on analog computing devices, such as the Hughes E-9 and MG-3 system. Considerable flexibility in the mode of operation is provided for. The equipment specified for the aircraft will enable operation under:

- (a) Close control, defined as continuous transmission of commands to the interceptor via data link from GCI to vector the interceptor into the most favourable position for attacking the target.
- (b) Modified close control, defined as intermittent transmission of target position and course vector to the interceptor by GCI, the interception problem being taken care of in the interceptor.
- (c) Broadcast control, defined as the transmission to all interceptors in an operating area of target position and course vector.

3.17.2 Location of Electronic Equipment: (Refer to Figs. 1, 19, 37 and 38). The electronic equipment in the CF-105, apart from cockpit operating components, is located in four principal regions:

- (a) Nose Compartment.
- (b) Electronic Equipment Bay (immediately forward of the Armament Bay).
- (c) Armament Bay.
- (d) Dorsal Compartment.

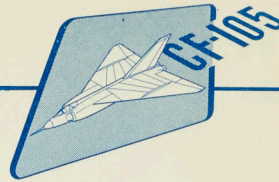

In addition, accelerometers are located in an area very close to the center of gravity, and antennas requiring special locations are housed in the most favourable areas available. These are described in detail in the paragraphs which follow.

The electronic equipment in the aircraft is divided into the following major groups:

Telecommunications, Fire Control, Navigation (other than radio aids), and Flight Control System.

3.17.3 Communication Equipment:

3.17.3.1 UHF Communication: An AN/ARC-34 UHF Transmitter-Receiver is provided for voice communication, air-to-air and air-to-ground. The transmitter-receiver is located in the electronic equipment bay. Antennas are provided at the top of the vertical fin and in the bottom of the electronic equipment bay in order to provide coverage in all important directions. These antennas will be shared with the UHF data link receiver and it is intended to provide diversity operation so that both antennas are used continuously. It is anticipated that this diversity operation will be secured by means of ferrite attenuators alternately keyed by means of a high frequency switching device, the frequency of commutation being high enough to avoid degradation of the received intelligence. AN/ARA-25 UHF homing equipment will be provided in conjunction with AN/ARC-34. This device is discussed further under Electronic Countermeasures, sub-para. 3.17.6.

3.17.3.2 UHF Data Link: Either AN/ARR-39 or AN/ARR-43 UHF data link receiving and de-coding equipment for reception of interception control and automatic GCA information will be accommodated in the radar nose. As discussed under UHF Communication, the two UHF antennas will be used for both communication and data link with commutation between them to provide for continuous contact regardless of interceptor attitude.

3.17.3.3 Interphone: AN/AIC-10 interphone system is provided, giving both crew members access to the UHF communication transmitter and selection of any or all voice receiver outputs. An external interphone connection point is provided, tying in with the interphone function of the AN/AIC-10.

3.17.4 Navigation Equipment:

3.17.4.1 Low Frequency Radio Compass: AN/ARN-6 low frequency radio compass equipment is provided, the receiver being located in the electronic equipment bay. Both cockpits have control facilities, tuning being done remotely by means of AN/ARA-19 remote tuning servo equipment. A flush ferrite loop, being developed by Bendix Radio for the AN/ARN-6 from the commercial flush radio compass loop, will be installed in the underside of the electronic equipment bay. A large flush panel over the loop will accommodate the sense antenna in close proximity to the receiver, the resulting reduction in sense antenna lead capacity being employed to offset the low effective height of this type of antenna.

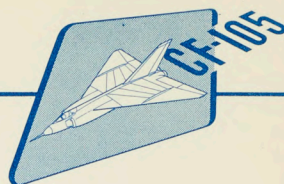

3.17.4.2 TACAN: AN/ARN-21 TACAN equipment will be accommodated as an alternative to the Doppler ground track and ground speed device described below. The TACAN equipment will be housed in the electronic equipment bay and will use the same antennas as the L-band air-to-ground IFF. These are dealt with in detail under Identification, sub-para. 3.17.5.

3.17.4.3 Doppler: The Doppler ground track and ground speed detection equipment being developed by the Canadian Defence Research Board will be accommodated in the electronic equipment bay as an alternative to TACAN. A radome sandwich panel in the underside of this bay will be designed for optimum transmission at the frequency of the equipment. The Doppler device will feed data to the navigation and interception computer equipment described later.

3.17.4.4 Radio Altimeter: AN/APN-71 Flareout Radar Altimeter will be installed on the ventral center line of the aircraft, providing altitude information to the cockpit indicator and also to the flight control system.

3.17.4.5 Compass: A J-2 type of flux valve compass is provided. In line with the objective of integrating the gyro requirements for the various electronic systems, it is expected that the directional gyro of this compass will be integrated with and stabilized by the vertical gyro which also serves the fire control system, flight control system and Doppler radar antenna stabilization.

3.17.4.6 Navigation and Interception Computers: The airplane will carry the navigation and interception computer being developed to fill the requirements of the RCAF for a dead-reckoning device to fulfil the following functions:

- (a) Navigation to intercept targets.
- (b) Return to base course computation.
- (c) Computation of distance to destination.
- (d) Collision or pursuit course navigation to a desired point which may be a moving target.
- (e) Computation of time to go on the basis of fuel remaining.
- (f) Indication of ground position.

This computer will be capable of drawing information from TACAN, data link or Doppler sources and will also be designed to continue computation by dead-reckoning, when data inputs are interrupted, on the basis of the last data received. Outputs will be included to enable the courses computed by the navigation interception computer to be executed by the flight control system automatically.

3.17.5 Identification Equipment:

3.17.5.1 Air-to-Ground IFF: The CF-105 will carry AN/APX-19 or AN/APX-25

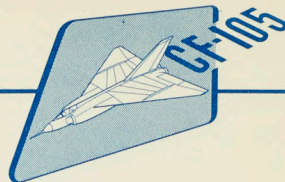

Mk X IFF transponder equipment in the electronic equipment bay along with flush antennas in the dorsal and ventral surfaces of the fuselage. The transponder will be commutated between the two antennas. The same antennas will also serve the TACAN system when it is carried. In the case of TACAN, the received signal indication ("Flag Alarm") will be used to switch between antennas in case of signal failure, to provide continuous contact regardless of aircraft attitude.

3.17.5.2 Air-to-Air IFF: AN/APX-26 air-to-air IFF interrogator-responder and AN/APX-27 air-to-air IFF transponder, or their equivalents, will be installed. The AN/APX-26 group will be installed in the radar nose and will be integrated with the radar antenna and waveguide. The transponder antenna, located in the vertical fin, will be connected by waveguide to the equipment group in the dorsal electronic compartment.

3.17.6 Electronic Countermeasures:

3.17.6.1 UHF Homer: As noted under UHF Communication, AN/ARA-25 automatic UHF direction finding equipment will be installed in conjunction with AN/ARC-34 to enable the interceptor to home on sources of UHF communication or data link jamming. In addition, this homing system will be available for use as a navigation and approach aid. The UHF homer is located on the nose wheel door.

3.17.6.2 Radar Homer: AN/ARD-10 broadband radar homer equipment will be installed in the radar nose to provide facilities for homing on sources of radar illumination or jamming.

3.17.7 Fire Control System: The fire control system of the CF-105 is a version of the Hughes E-9 and MG-3 family.

3.17.7.1 Radar Sub-System: The radar sub-system performs automatic search, automatic tracking, ground mapping and interrogation and reception of radar ground beacons. During automatic tracking the radar sub-system supplies the computing sub-system with the necessary information for computing an attack course against the target on which the radar is locked. When using semi-active X-band missiles the radar illuminates the target throughout the missiles' flight so that reflected RF energy is available for missile guidance.

3.17.7.2 Computer Sub-System: The computer sub-system includes an electronic analog computer capable of generating lead-collision missile attacks and either lead-pursuit or lead-collision rocket attacks. It also schedules the preparatory operations which must be performed on the missiles before they are launched, and continuously computes time remaining until missile firing. Signals are supplied at specific intervals to the missile auxiliaries sub-system to control the sequence of the pre-launch operations required to set up the missiles. The computer provides for "snake" operation to enable the interceptor to follow another aircraft accurately and safely regardless of visibility. In this non-attack mode of operation the computer provides steering signals for a lead-pursuit course.

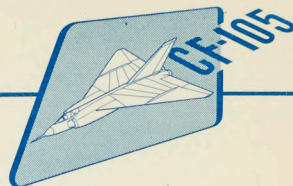

3.17.7.3 Controls and Power Requirements: Controls and cockpit equipment are generally similar to the E-9 fire control system while the central power supply and missile auxiliary configuration similar to the MG-3 are used. The multi-purpose analog computer and 250 kilowatt peak power tunable radar common to both systems are employed. To increase the AI range capabilities, accommodation is provided for a 35 inch diameter antenna swept volume. With conventional gimbaling a 30 inch diameter dish can thus be accommodated, while with an antenna gimballed in the vicinity of its center of gravity, dish sizes approaching the limits of the swept volume may be carried.

The radar and computer components of the system are accommodated in racks in the radar nose, with a plenum chamber in the center of the nose compartment supplying adequate cooling air for all operation environments.

The high voltage DC requirements of all parts of the fire control system are supplied by a multi-output rotating generator driven by a fixed frequency AC motor from the aircraft 400 cycle power supply. Regulators are provided for the various voltage outputs, primarily to limit the effect of transients and to isolate the major portions of the system from each other with regard to the effects of such transients.

3.17.7.4 Missile Auxiliaries: The missile auxiliaries sub-system consists of central computing equipment and individual channels for the setting up of proper parameters in the missiles. With GAR-1 missiles the functions of the missile auxiliaries sub-system include:

- (1) Application of external power to critical circuits within the missile.
- (2) Transfer to internal missile power.
- (3) Servoing of the missile antenna into alignment with the radar antenna.
- (4) Servoing of the radar transmitter and the missile receiver into frequency correspondence.
- (5) Servoing of the missile range gate into time coincidence with the radar range gate.
- (6) Computing optimum missile firing range.
- (7) Computing the missile guidance and control parameters in accordance with aerodynamic conditions.
- (8) Blowing of missile attenuator fuses to set the computed parameters into the missiles.

Equivalent operation for 'Sparrow 2' missiles would be provided by suitable missile auxiliaries conforming to the requirements of the 'Sparrow'.

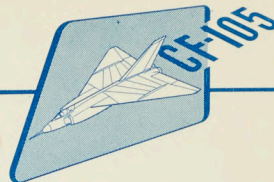

3.17.7.5 Air Data Computer: The fire control system includes an air data computer which provides, to a high degree of accuracy, the following quantities:

- (1) Mach number.
- (2) True airspeed.
- (3) Dynamic pressure.
- (4) Missile jump angle.
- (5) True angle of attack.
- (6) Air density times speed of sound.

The air data computer receives inputs from a probe projecting from the apex of the radome, carrying the pitot-static head, relative wind direction sensors and radome de-icing fluid dispenser. This computer is provided primarily for weapon launching computation requirements but also permits weight and space economy by integrating similar requirements for the flight control system and certain flight instruments.

3.17.7.6 Location of Fire Control Equipment: The radar, computers (multi-purpose attack computer, air data computer and missile auxiliaries computers) and system computer test units are contained in the radar nose compartment. The missile auxiliaries associated with the individual missile channels are housed in the armament bay adjacent to the missiles while power supply equipment and weapon salvo selection units and power supply components are accommodated in the electronic equipment bay and the general equipment bay just forward of it. Weapon launching timing devices, including the intervalometer and weapon extension controls, are in the armament bay.

With the objective of achieving economy of equipment and weight, the gyro requirements for the fire control system will be integrated as far as possible with those for the flight control system, the gyros being in a favourable location relative to the center of gravity of the aircraft in the dorsal electronic compartment.

3.17.7.7 Optical Sighting: An optical sight is provided in the pilot's cockpit for use at low altitudes where airborne radar tracking is ineffective due to ground clutter.

3.17.8 Flight Control System: The flight control system of the CF-105 will be a development of the Minneapolis-Honeywell E-10 autopilot. This is a rate system

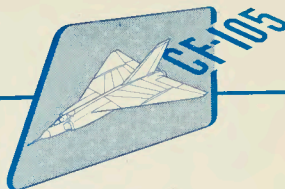

using DC signals and operates through high performance hydraulic servos. The flight control system will provide the following functions:

- (a) Stabilization and damping of the aircraft.
- (b) Flight in response to manual commands of course, altitude or Mach number.
- (c) Automatic flight response to commands of the navigation and interception computer.
- (d) Automatic attacks under the control of the fire control system.
- (e) Automatic landing under the control of AGCA commands transmitted by data link, the closing phase of the landing being controlled by the flareout altimeter.

Manual commands will be inserted by means of stick force sensing using the aircraft's conventional flight controls. The rate gyros and accelerometers of the flight control system will be located close to the C.G. in the dorsal electronic compartment, the remainder of the electronic portions being in the radar nose. Air data and vertical gyro reference requirements of the flight control system will be integrated as far as possible with those of the fire control system and the Doppler antenna stabilization.

3.18 Armament:

3.18.1 Air-to-Air Guided Missiles: (Refer to Fig. 37). The CF-105 armament consists of four Hughes 'Falcon' radar seeker guided missiles and four infra-red equivalents carried in two rows of four in the armament bay. The rear four will be Infra-Red missiles and the forward four will be radar seeker missiles. Missile lowering is by means of a hydraulically operated parallel link mechanism.

Doors underneath each missile are mechanically linked to the lowering mechanism and will open to permit extension and will close again as the missile approaches the fully extended position. Aerodynamic considerations dictate that the armament bay doors be closed with the missiles in extended launching position.

In order to avoid homing and aerodynamic interference between missiles, inboard missiles will be angled out $1^{\circ} 40'$ from the airplane center line and outboard missiles 5° from the airplane center line at the time of firing. Also, missiles are angled 4° down from the airplane datum to ensure clean separation from fuselage.

The missiles are stowed 3° nose down relative to the fuselage datum and parallel to the aircraft center line. Rotation to 4° nose down will take place gradually during lowering. Transition to $1^{\circ} 40'$ or 5° in azimuth will take place as soon as the missile fins are clear of the doors.

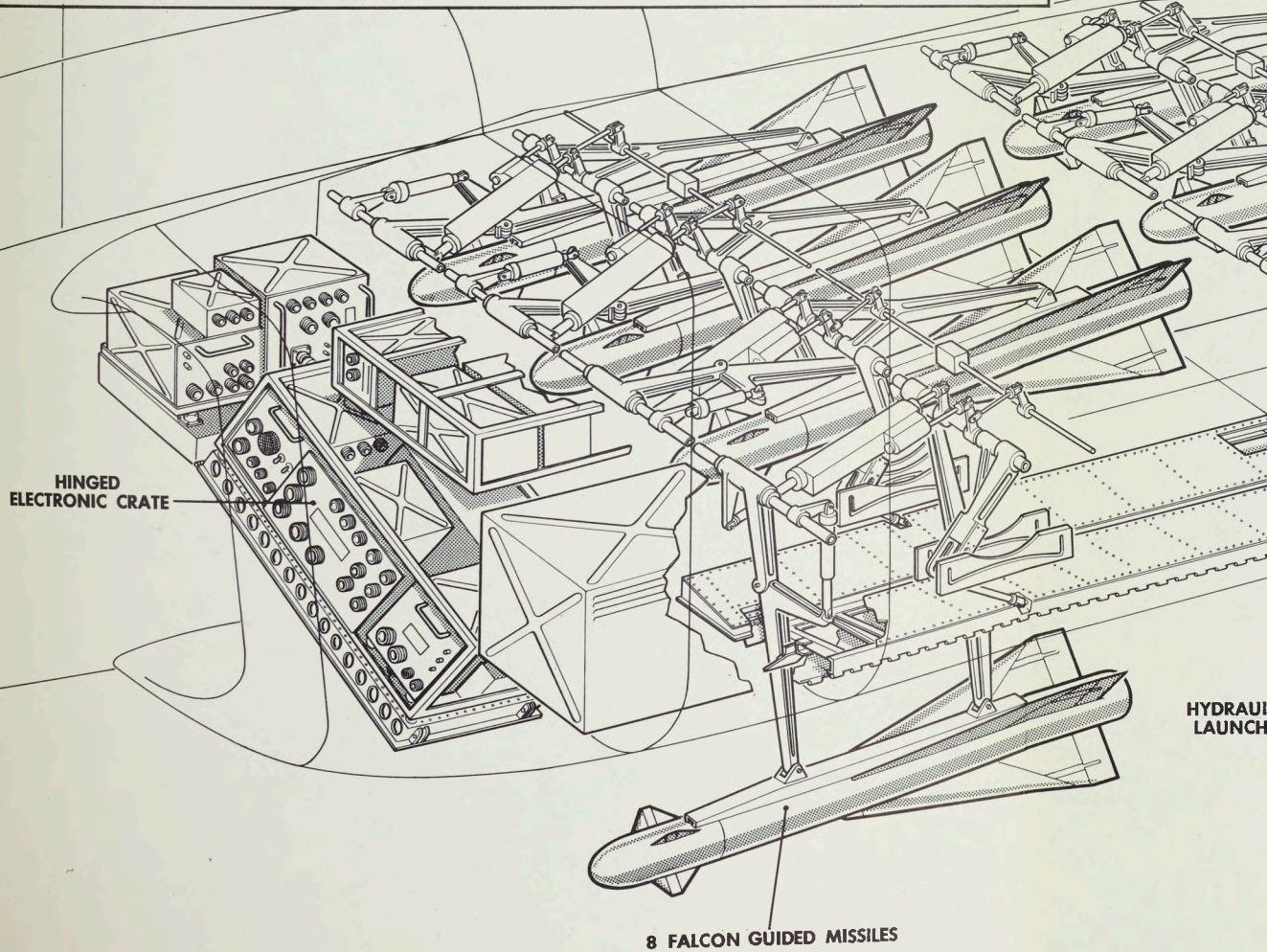
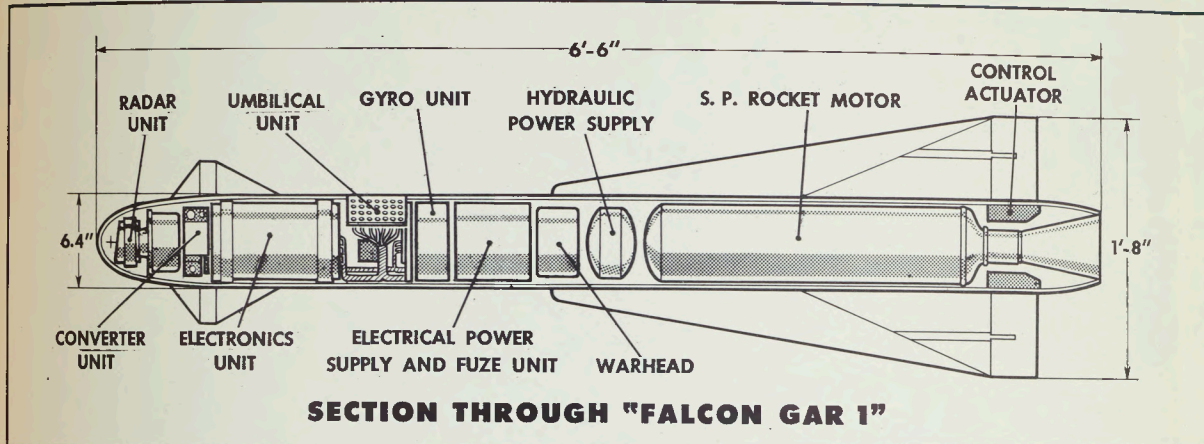
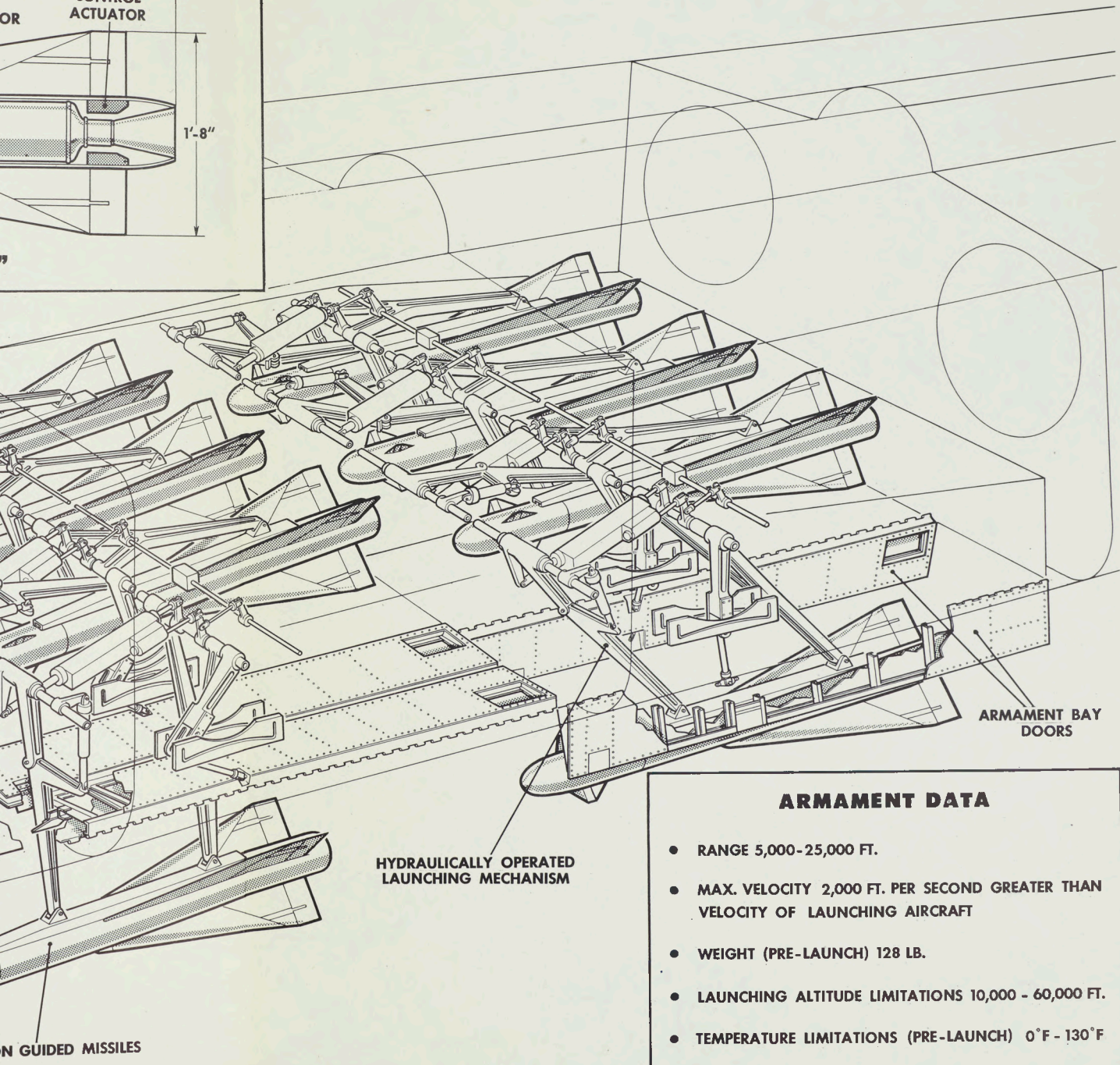
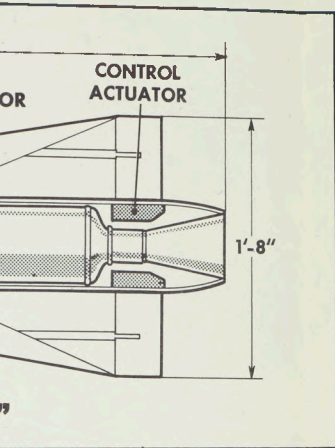

FIG. 37 ARMAMENT AND ELECTRONIC EQUIPMENT INSTA



ARMAMENT DATA

- RANGE 5,000-25,000 FT.
- MAX. VELOCITY 2,000 FT. PER SECOND GREATER THAN VELOCITY OF LAUNCHING AIRCRAFT
- WEIGHT (PRE-LAUNCH) 128 LB.
- LAUNCHING ALTITUDE LIMITATIONS 10,000 - 60,000 FT.
- TEMPERATURE LIMITATIONS (PRE-LAUNCH) 0°F - 130°F

AND ELECTRONIC EQUIPMENT INSTALLATIONS - FALCON

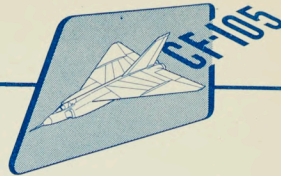

To permit servicing of the missiles and missile auxiliaries, provisions are included for partial lowering of the launchers, the doors being retained fully open.

The hydraulic system will consist of a hydraulic jack with an uplock operating each missile launcher extension gear and hydraulic accumulators sufficient to extend all eight missiles in one pass. Retraction power is supplied by hydraulic pumps.

The extension of each missile is regulated by having the jack follow a programmed input and this input is such that accelerations of the missile during lowering are not excessive. The programmed input is accomplished by a cam in a programming box, which will drive a position error hydraulic servo valve on each lowering jack.

Missiles may be fired in a salvo of eight, a salvo of either four radar seekers or four infra-red seekers or a mixed salvo of two radar seekers and two infra-red seekers. In launching mixed salvos the rear missiles will be fired first, their launchers being left extended while the front missiles are lowered and fired. All empty launchers will then be retracted simultaneously.

In the case of an attack with either four radar seeker or four infra-red missiles the appropriate row will be lowered and fired and the empty launchers retracted immediately.

An alternative armament of three Douglas 'Sparrow 2' fully active homing missiles can be accommodated, stowed in a similar manner to 'Falcon' missiles - refer to Fig. 38.

3.18.2 Rockets: A further alternative armament installation can be arranged along either of the following lines for conditions which might be unsuitable for missiles, such as low altitude attacks:

- (a) An expendable rocket package containing fifteen 2-inch rockets can be fitted in place of each Falcon missile giving a total of 120 rockets.
- (b) With the launching gear strengthened to allow for increased loads there is sufficient space to accommodate 8 launchers each containing 25 rockets, or a total of two-hundred 2-inch rockets.

3.19 Furnishings and Equipment:

3.19.1 Accommodations for Personnel:

3.19.1.1 Crew Seats: The pilot and radar operator will each be provided with an upward ejection seat for ejection under emergency conditions. Each seat will be equipped with a safety belt and shoulder strap assembly.

3.19.1.2 Anti 'g' Suit Provisions: Provision will be made at each crew station for

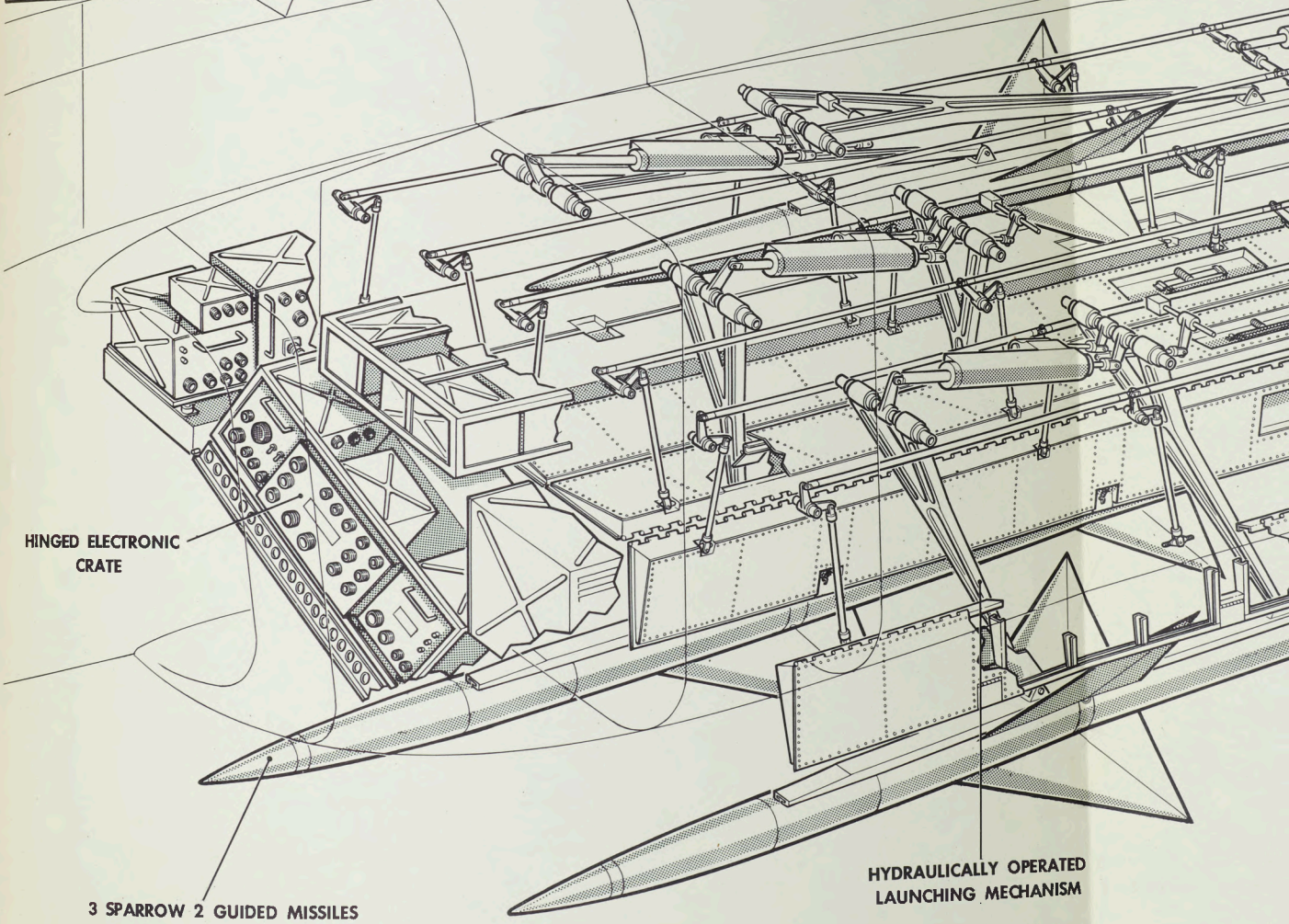
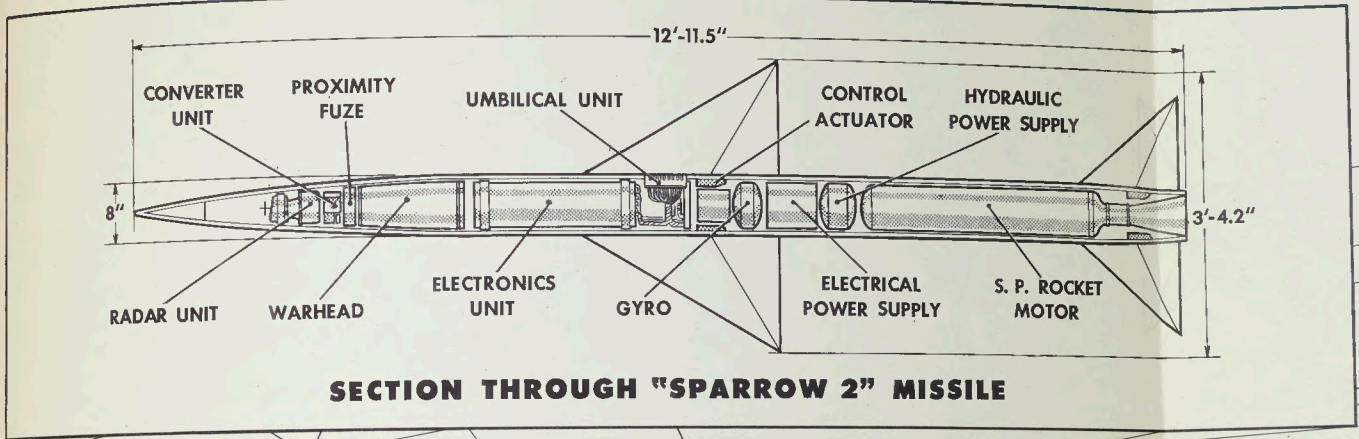

FIG. 38 ARMAMENT AND ELECTRONIC EQUIPMENT INSTA

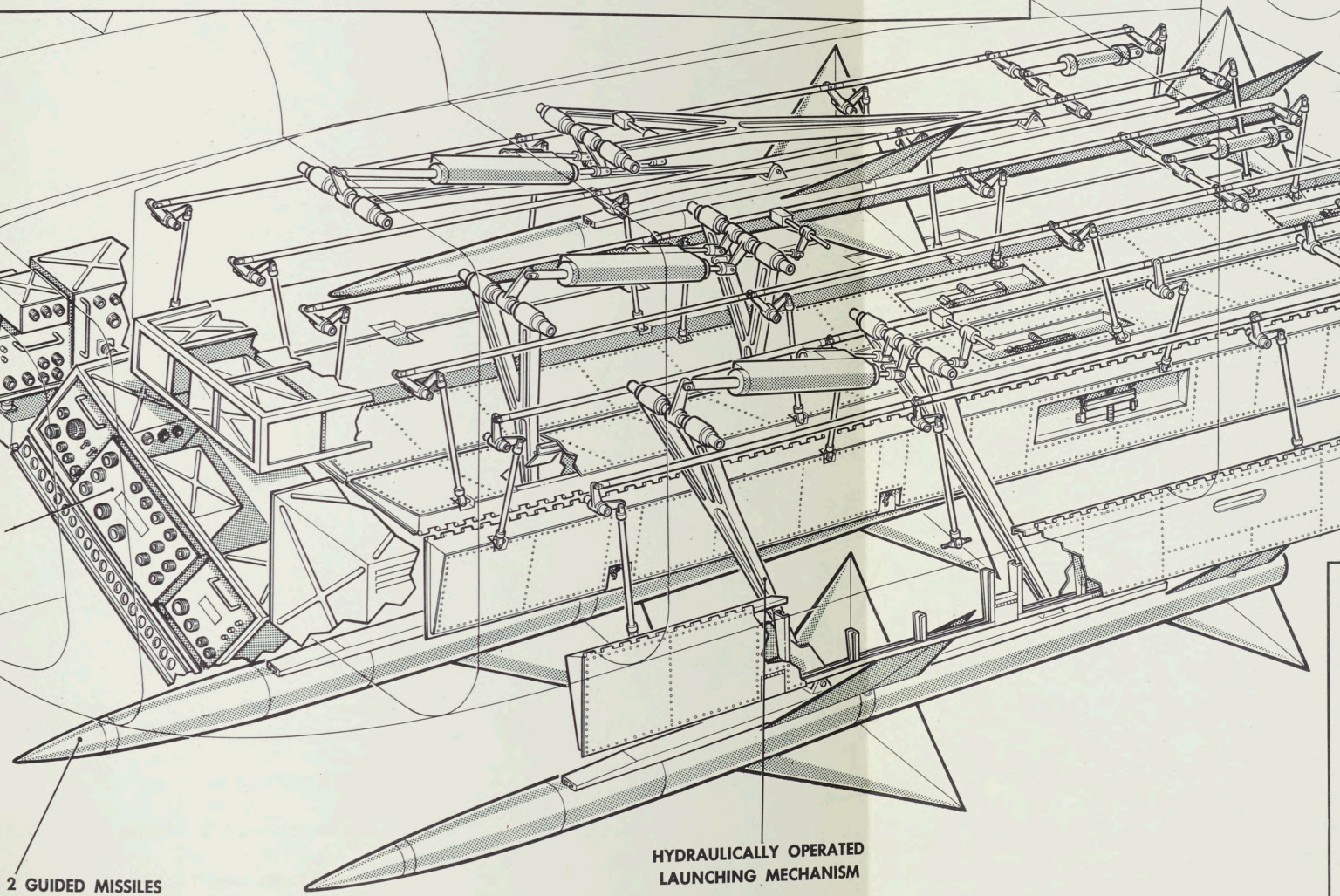
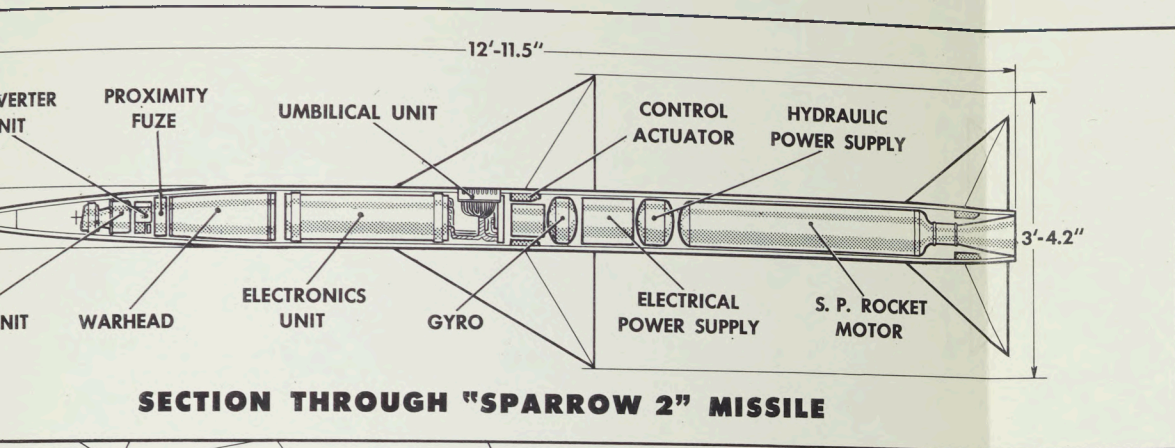
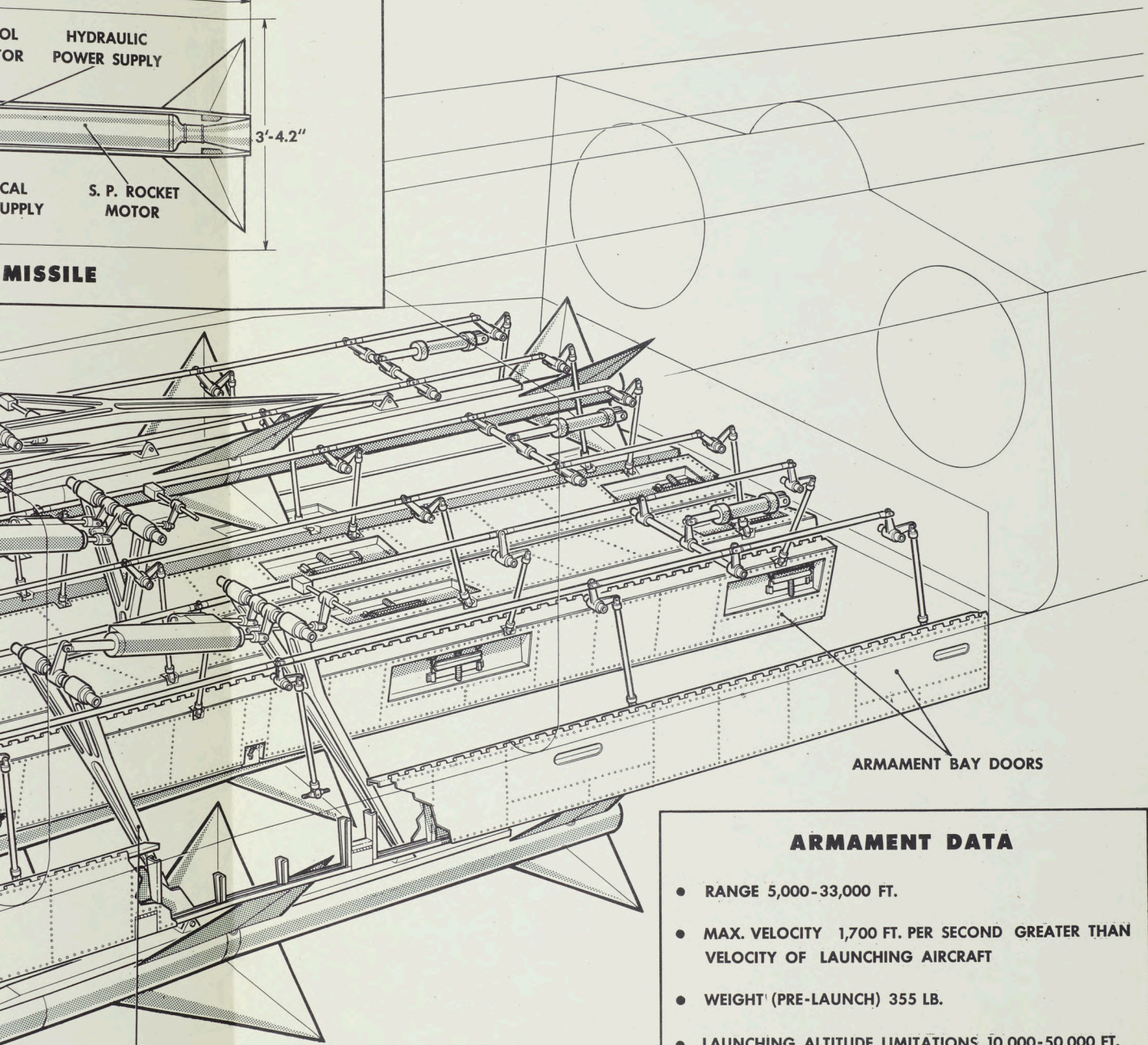
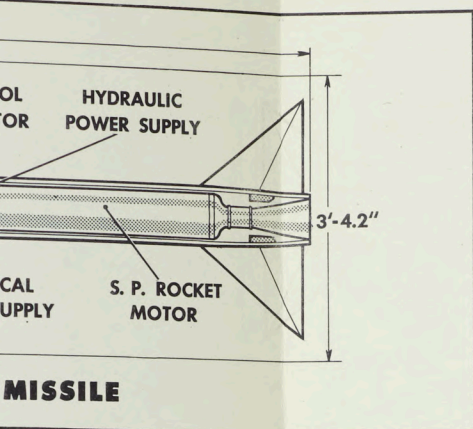
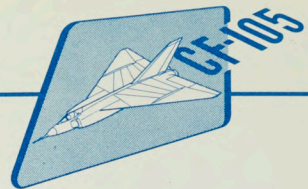

FIG. 38 ARMAMENT AND ELECTRONIC EQUIPMENT INSTALLATIONS - SPARROW



HYDRAULICALLY OPERATED LAUNCHING MECHANISM

ARMAMENT DATA

- RANGE 5,000-33,000 FT.
- MAX. VELOCITY 1,700 FT. PER SECOND GREATER THAN VELOCITY OF LAUNCHING AIRCRAFT
- WEIGHT (PRE-LAUNCH) 355 LB.
- LAUNCHING ALTITUDE LIMITATIONS 10,000-50,000 FT.
- TEMPERATURE LIMITATIONS (PRE-LAUNCH) -75°F TO +150°F (FOR ROCKET MOTOR)

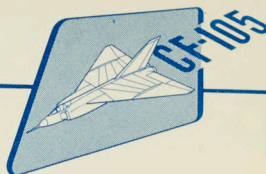

the use of a service supplied anti 'g' suit. The air to inflate these suits will be supplied by the low pressure pneumatic system.

3.19.1.3 Partial Pressure Suit Provision: Provision will be made at each crew station for the use of a service supplied partial pressure suit.

3.19.2 Miscellaneous Equipment: Miscellaneous equipment will be fitted as required by the RCAF.

3.19.3 Furnishings: A protective anti-skid coating will be applied to the cockpit floor in areas subjected to wear.

3.19.4 Emergency Equipment:

3.19.4.1 First Aid Equipment: Provision is made in both cockpits for the installation of two service supplied shell dressings in a position accessible to the respective crew member.

3.19.4.2 Crash Equipment: A crow bar will be provided in each cockpit in a position accessible to the respective crew member.

3.19.4.3 Fire Extinguisher: A hand fire extinguisher will be provided in each cockpit in a position accessible to the respective crew member.

3.19.5 Oxygen Equipment: A liquid oxygen system designed to the requirements of D.O.R., A.F.H.Q., D.N.D., will be installed in the airplane. The system will provide the crew with the necessary oxygen for breathing and also provide for the inflation of partial pressure suits.

3.19.6 Emergency Rescue Equipment: Such equipment as required by the RCAF will be fitted.

3.20 Air Conditioning and Anti-Icing Equipment:

3.20.1 Air Conditioning: Refer to sub-para. 3.15.2 and Fig. 35.

3.20.2 Anti-icing:

3.20.2.1 Anti-icing of Non-transparent Areas: The radome and other critical instrument reference areas and the intake ducts will be fitted with anti-icing means.

3.20.2.2 Anti-icing, Defrosting and Defogging of Transparent Areas: The areas to be protected are the windscreen and the canopy windows. The exact method which will be used is still being investigated.

3.21 Photographic Equipment: This equipment will not be fitted to this airplane.

