

UNCLASSIFIED

Secret

COPY.....

AR-31.

**JOINT REPORT ON
COCKPIT INSTRUMENTATION**

FILE IN VAULT

ISSUE NO. 2

for the
**ARROW
WEAPONS SYSTEM**

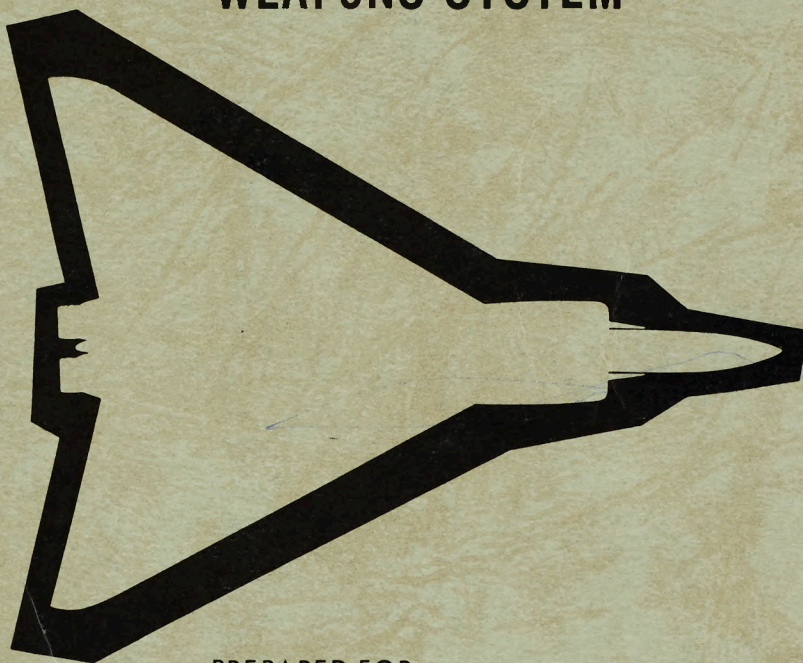

PREPARED FOR
CONTRACT AF 33 (600) 33522

PREPARED JOINTLY BY
RADIO CORPORATION OF AMERICA
Camden 2, N.J.

and

AVRO AIRCRAFT LTD
Malton, Ontario

June 23, 1958

UNCLASSIFIED

Secret

Secret

7008580139(1)

AR-31

JOINT REPORT ON COCKPIT INSTRUMENTATION

ISSUE NO. 2

for the ARROW WEAPONS SYSTEM

"THIS INFORMATION IS FURNISHED UPON THE CONDITION THAT IT WILL NOT BE RELEASED TO ANY OTHER PERSON OR ORGANIZATION WITHOUT THE SPECIFIC AUTHORITY OF THE DEPARTMENT OF THE ARMY OR THE DEPARTMENT OF THE AIR FORCE. THAT IT WILL BE USED FOR OFFICIAL PURPOSES ONLY; THAT INDIVIDUAL OR CORPORATE RIGHTS OR INTERESTS IN THE INFORMATION, WHETHER PATENTED OR UNPATENTED, WILL BE RESPECTED AND THAT THE INFORMATION BE PROVIDED SUBSTANTIALLY THE SAME DEGREE OF SECURITY AFFORDED BY THE DEPARTMENT OF DEFENSE OF THE UNITED STATES."

Classification cancelled/changed to UNCLASSIFIED
by authority of [Signature] (date) [Date]

WARNING

This document contains information affecting the national defense of the United States within the meaning of the Espionage Laws, Title 18, U.S.C., Sections 793 and 794. The transmission or the revelation of its contents in any manner to an unauthorized person is prohibited by law.

GR58 MAHF 320

PREPARED FOR
CONTRACT AF 33 (600) 33522

PREPARED JOINTLY BY
RADIO CORPORATION OF AMERICA
Camden 2, N.J.

and
AVRO AIRCRAFT LTD
Malton, Ontario

June 23, 1958

Secret

SECRET
UNCLASSIFIED

FOREWORD

This revised issue (No. 2) of the joint Cockpit Report reflects all changes necessitated by the re-design of displays and controls. The modifications are a result of the mockup review and further human engineering and operational studies that have taken place in the normal course of the development program. This arrangement of displays and controls combines conventional instruments with individual new designs that were available, or could be developed, in time for the ARROW Weapon System. The instruments and arrangement shown apply to System No. 4 and subsequent systems; the first of which will be installed in Aircraft Number 25209.*

General considerations and cockpit arrangements are set forth in Part I. Part II includes drawings and detailed description of the displays and controls.

*All ARROW aircraft will be identified by a 5-digit serial number beginning 252. The last two digits refer to the aircraft numbers mentioned in this report, e.g. 25209 is Aircraft No. 9.

SECRET

TABLE OF CONTENTS

	Page
PART I - LAYOUT OF INSTRUMENTS, DISPLAYS, AND CONTROLS FOR PILOT'S AND OBSERVER'S COCKPITS	
A. Introduction	1
B. Cockpit Layouts	1
1. Pilot's Cockpit	1
2. Observer's Cockpit	7
PART II - DETAILED DESCRIPTION OF DISPLAYS AND CONTROLS	
A. Pilot's Panel	11
1. Pilot's Radar Indicator and Controls	11
2. Master Warning Lights	17
3. Indicated Airspeed Meter	17
4. Mach Indicator	18
5. Flight Director/Attitude Indicator	18
6. Pilot's Destination Indicator and Observer's Destination Indicator	20
7. Pilot's Destination-Indicator Bearing Control	21
8. Altimeter	21
9. Command- and Target-Altitude Counter (Pilot)	22
10. Rate-of-Climb Indicator	22
11. Engine Performance Indicator	22
12. Fuel Quantity Meter	23
13. UHF Channel Indicator	24
14. Optical Sight	24
15. Miscellaneous Indicators and Instruments	25
B. Pilot's Consoles	27
1. AFCS Control Panel	27
2. Damper Control Panel	27
3. ARC-552(UHF) Control Panel	28
4. Armament Control Panel	28
5. Stores Jettison Panel	31
6. ARN-6 (Radio Compass) Control Panel	31
7. Pilot's Destination-Indicator Heading Control	34
8. AIC-10A (Intercom) Control Panel	35
9. Panel and Console-Lights Control Panel	36
10. Other Console Controls	36
C. Observer's Panel	44
1. OBS Bail-out Command Light	44
2. Range and Range-Rate Meter	44
3. Observer's Radar and IR Indicator and Controls	44
4. Observer's Radar/IR Control Panel	47
5. Altitude Data Counters	50

~~CLASSIFIED~~
TABLE OF CONTENTS (Cont'd)

	Page
PART II - DETAILED DESCRIPTION OF DISPLAYS AND CONTROLS (Cont'd)	
D. Observer's Consoles	50
1. In-Flight Test Panel	50
2. Radar Auxiliary Control Panel	52
3. ARD-501(ECM Ilomer) Control Panel	54
4. ARC-552(UHIF) Control Panel	54
5. ARC-552(UHIF) Channel Selector	56
6. ARR-48(Data Link) Control Panel	56
7. Antenna-Duplexer Control Panel	58
8. True-Airspeed Counter	59
9. Total-Fuel Indicator	59
10. Wind-Data Display	59
11. Target-Data Display	60
12. Navigation-Computer Control Panel	62
13. APX-25A (IFF) Control Panels	65
14. APX-26/27 (IFF) Control Panel	65
15. Additional Panels	66
E. Observer's Hand Control	66
1. Observer's Hand Control Panel	66

LIST OF ILLUSTRATIONS

UNCLASSIFIED

Figure		Responsibility	Page
1	Layout of Pilot's Cockpit		3
2	Layout of Observer's Cockpit		8
3	Pilot's Indicator and Controls	RCA	11
4	Display for a Lead-Collision Attack with Rockets		12
5	Display for Phase I of a Lead-Collision Snap-Up Attack with Rockets		13
6	Display for Breakaway Rocket		13
7	Display for Lead-Pursuit Missile Attack		14
8	Display for Lead-Collision Missile Attack		15
9	Display for Lead-Collision Snap-Up Missile Attack, Phase I		16
10	Indicated Airspeed Meter	AVRO	17
11	Mach Indicator	RCA	18
12	Flight Director/Attitude Indicator	RCA	19
13	Destination Indicator	RCA	20
14	Pilot's Destination-Indicator Bearing Control	RCA	21
15	Altimeter	AVRO	22
16	Command- and Target-Altitude Counter	RCA	22
17	Rate-of-Climb Indicator	AVRO	23
18	Engine Performance Indicator	AVRO	23
19	Fuel Quantity Meter	AVRO	24
20	UHF Channel Indicator	RCA	24
21	Landing Gear Position Indicator	AVRO	25
22	Turn and Slip Indicator	AVRO	26
23	Accelerometer	AVRO	26
24	G-trim Indicator	AVRO	26
25	Elapsed Time Clock	AVRO	26
26	AFCS Control Panel	RCA	27
27	Damper Control Panel	AVRO	27
28	ARC-552 Control Panel	RCA	28
29	Armament Control Panel	RCA	29
30	Landing-Gear Control and Stores Jettison Button	AVRO	32
31	ARN-6 Control Panel	RCA	33
32	Pilot's Destination-Indicator Heading Control	RCA	34
33	AIC-10A(C-824) Intercom Control Panel	RCA	36
34	Pilot's Panel and Console-Lights Control Panel	AVRO	37
35	Fire, Fuel, and Trim Control Panel	AVRO	38
36	Control-Surface Position Indicator	AVRO	38
37	Warning Panel	AVRO	39
38	Master Electrical Panel	AVRO	39
39	Oxygen Indicator and Miscellaneous Controls	AVRO	40
40	Air Conditioning Panel	AVRO	41

UNCLASSIFIED

LIST OF ILLUSTRATIONS (Cont'd)

Figure		Responsibility	Page
41	Circuit Breaker Panel	AVRO.....	42
42	Pilot's Canopy Switch Panel	AVRO.....	42
43	Engine Air-Bleed Panel	AVRO.....	43
44	Fuel and Oxygen Test Panel	AVRO.....	43
45	Range and Range-Rate Meter	RCA	44
46	Observer's Radar and IR Indicator and Controls	RCA	46
47	Observer's Radar/IR Controls	RCA	48
48	Altitude Data Counters	RCA	50
49	In-Flight Test Panel	RCA	51
50	Radar Auxiliary Control Panel	RCA	52
51	ARC-552 Control Panel (OBS/AI)	RCA	55
52	UHF Channel Selector	RCA	56
53	ARR-48 Data-Link Control ..	RCA	57
54	Antenna-Duplexer Control Panel	RCA	58
55	True-Airspeed Counter	RCA	59
56	Wind-Data Display.....	RCA	60
57	Target-Data Display.....	RCA	61
58	Navigation-Computer Control Panel	RCA	63
59	APX-25A Coder Control Panel	RCA	64
60	APX-25A Transponder Control Panel	RCA	64
61	APX-26/27 Control Panel.....	RCA	65
62	Observer's Panel and Console Lights Control	AVRO.....	67
63	Observer's Canopy Control	AVRO.....	67
64	Radar Hand Control.....	RCA	68

SECRET

UNCLASSIFIED

PART I

LAYOUT OF INSTRUMENTS,
DISPLAYS, AND CONTROLS
FOR PILOT'S AND OBSERVER'S
COCKPITS

SECRET

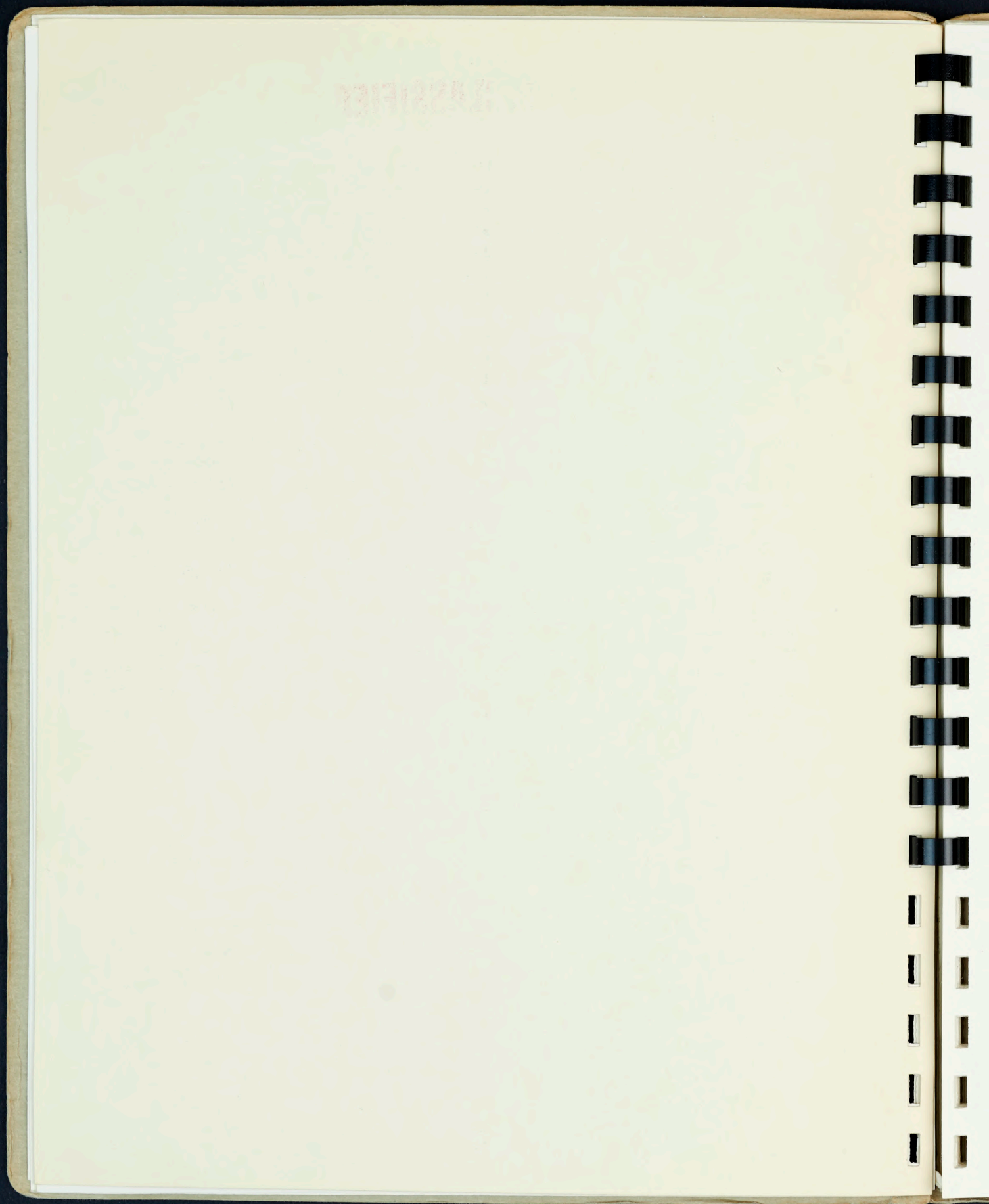

A. INTRODUCTION

At the outset of work it was recognized that the advanced performance capabilities of the ARROW aircraft called for advances in flight-control instrumentation, both for flight safety and for maximum utilization of the aircraft capability. Investigations were therefore initiated to evaluate new display techniques and integrated instrument systems that might be used for the aircraft. As a result, the new instruments that have been selected avoid the well-established shortcomings of conventional instruments without sacrificing reliability and simplicity of design. Drawings of the instruments and detailed descriptions are included in Part II of this report.

The present RCA/AVRO layout of instruments, displays, and controls for the cockpits is essentially that presented to the RCAF on September 17-25, 1957, at the Mockup Review held at the AVRO plant. All change requests of the ARROW 2 Mockup Board have been studied, and the present cockpit arrangements include everything that has been agreed upon.

Discussions were held with both RCAF and USAF operational personnel, and among RCA, Minneapolis-Honeywell, and AVRO. It was concluded that these layouts represent the optimum selection and arrangement, considering all aspects, including the requirements of the aircraft production schedule.

B. COCKPIT LAYOUTS

1. PILOT'S COCKPIT

The front cockpit in the ARROW aircraft (layout shown in Figure 1) contains a primary instrument panel and two consoles on which are mounted the controls and displays necessary to the performance of the pilot's duties in flight. The instrument panel contains the primary flight instruments basic to flight safety, navigation, fire-control and power-plant management. Consoles along each side of the cockpit, outboard of the ejection envelope and pilot's seat, contain auxiliary controls and displays necessary for the operation of various components of the aircraft and weapon systems.

a. Primary Flight Panel

The primary flight panel includes the instruments listed below:

Pilot's Indicator and Controls	Accelerometer
Indicated Airspeed Meter	Flight Director/Attitude Indicator
Mach Indicator	Pilot's Destination Indicator (PDI)
Altimeter	Engine-Performance Indicators (2)
Rate-of-Climb Indicator	Fuel-Quantity Meters (2)
Optical Sight	Command and Target Altitude Counters
Turn and Slip Indicator	Clock
Warning Lights (3)	Landing-Gear-Position Indicator
G-trim Indicator	UIIF-Channel Indicator
PDI Bearing Switch	

The arrangement of these instruments is illustrated in Figure 1.

The radar scope appears at the top center line with the combined flight director/attitude indicator below it and the destination indicator at the bottom. The air speed and mach indicator are placed to the left, and the altimeter and rate-of-climb indicator are at the right of the flight director/attitude indicator, forming a centered cross on the panel which contains the majority of the most frequently used displays. This arrangement follows closely the "cross-hair" layout employed in the new USAF integrated instrument panel concepts.

Placement of the attack radar display at the top of the panel was largely a compromise dictated by the narrowness of the upper portion of the panel and the desire to keep associated instruments grouped together in order to reduce eye movements. While it is advisable to place the primary flight instruments high on the panel, experimental evidence indicates that arrangement of these instruments should be in the minimum number of horizontal rows in order to reduce the number of vertical eye movements required in scanning the panel. Putting the radar display and associated controls in any other place would have spread the other instruments vertically, thus requiring a greater number of vertical eye movements than does this configuration. The position of the radar scope above the flight director/attitude indicator should facilitate transition from radar flight control to contact flight conditions, particularly during visual identification where guidance to the target is by radar but positive visual identification is required.

A fixed-reticle, collimating optical sight will be mounted above the pilot's indicator under the windscreen frame. The design of this sight, which will incorporate all features desired by the RCAF is not yet complete.

Several changes have occurred on the primary flight panel since the first design study for the ARROW cockpit installation was issued. A "moving horizon" type of flight director/attitude indicator has replaced the "moving aircraft" display previously proposed for the ARROW. This action was initiated to comply with the directives of the RCAF. The pilot's destination-indicator bearing control has been relocated on the pilot's main panel adjacent to the PDI itself. The switch is an independent, integrally lighted unit. The magnetic compass shown in the first report has been eliminated. Several considerations were involved in this decision, the major one being that the magnetic compass would tend to read erroneously due to its proximity to the mu-metal shielding around the pilot's indicator and to magnetic fields in its high voltage supply. A second reason for eliminating the compass was that magnetic heading is displayed on the pilot's destination indicator by use of the flux valve. Other instruments such as the Mach indicator, engine-performance indicators, landing-gear position indicator, accelerometer, etc. have been relocated to make better use of the limited space available.

b. Pilot's Consoles

The tasks required of the pilot were taken into consideration in the arranging of the equipments on the consoles. Normally, the pilot will be monitoring the control stick with his right hand.

Therefore, the following critical equipments requiring hand operation are located on the left console.

POWER
OBS

EXTERNAL

PARKING

LANDING GEAR POSITION

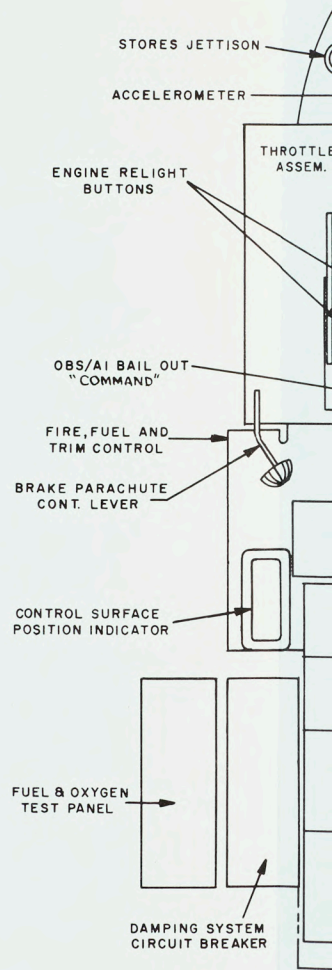

UNCLASSIFIED

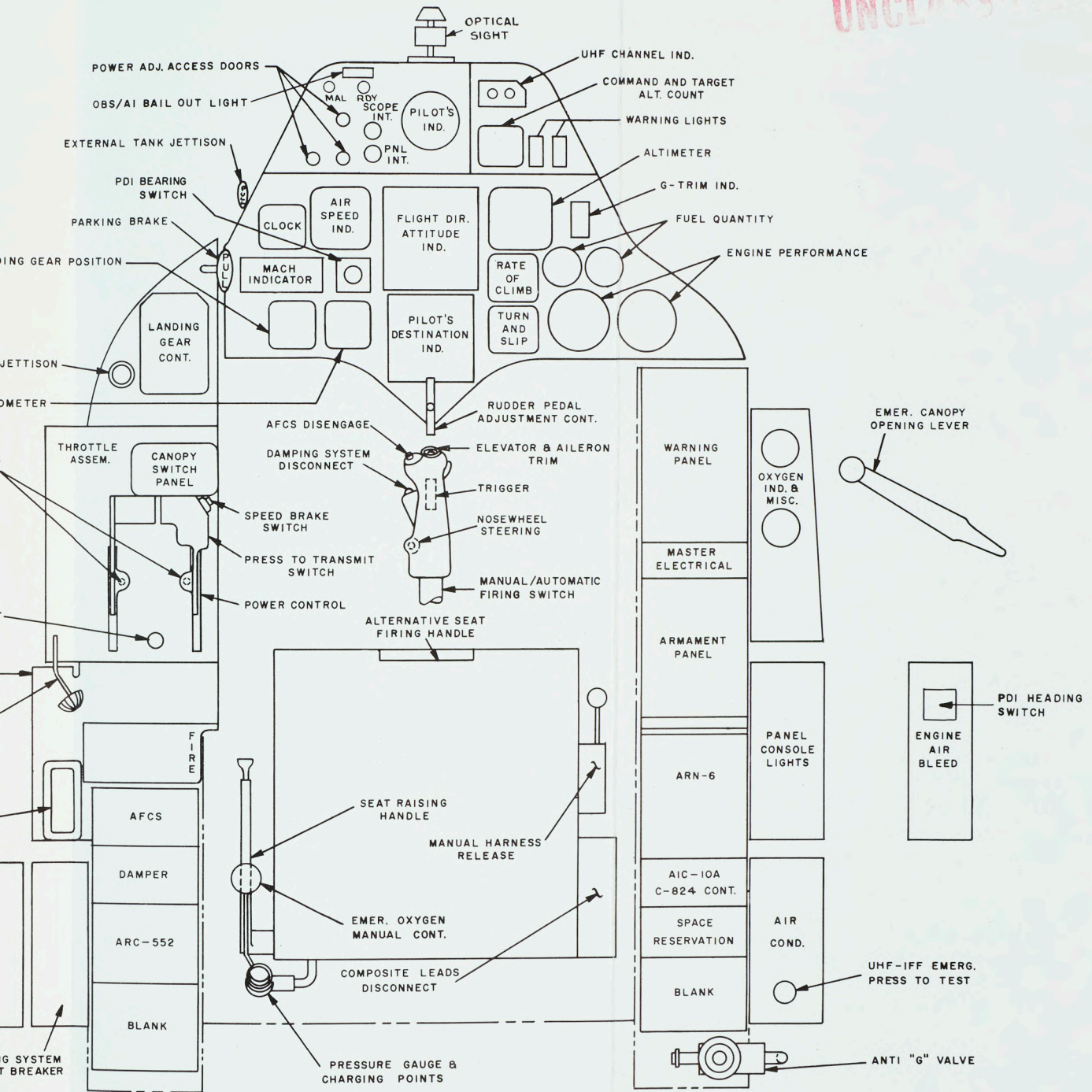

Figure 1. Layout of Pilot's Cockpit

1) **Left Console:**

Throttle Quadrant,
Fire, Fuel, and Trim Control Panel,
Automatic Flight-Control System and Damper Control Panels,
Damping System Circuit-breaker Panel,
ARC-552 (UIHF) Control Panel including Transfer Switch,
Canopy Switch Panel,
Control-Surface Position Indicator (visual only),
Landing-Gear Control,
Fuel and Oxygen Test Panel,
Stores Jettison, and
Observer Bail-Out Command Switch.

Because the position of the throttle quadrant is fixed, the remaining controls are arranged fore and aft of this location in the order of their importance. Figure 1 shows the arrangement for this console. The aircraft and engine functions and emergency switches are located just behind the throttle quadrant. These are followed by the automatic flight-control system panel, and the control-surface position indicator; the ARC-552 is located farthest aft on this console. Farthest forward, in front of the throttle quadrant is the landing-gear control. Just behind it and in front of the throttle quadrant are the antiskid switch, canopy switch, and taxi-light control. Although this area is quite far forward, it is not an ideal location for critical controls, because of the location of the throttles. The location to the rear of the control-surface position indicator, which lies between the main console rack and the fuselage, contains the damping-system circuit-breaker panel and the fuel and oxygen test panel. The observer bail-out command switch is located on the vertical aft face of the throttle quadrant. This recessed, press-to-operate switch stands alone on this surface and should be easily located under bail-out conditions.

2) **Right Console**

The basic problem of the layout for the right-hand console differs from that of the left console. Since the pilot's right hand is more or less continually occupied, it is not desirable to place critical controls on this console regardless of location. The exception to this being the engine-start controls, which are operated during the time when the left hand is fully occupied with the throttle.

Because there is no throttle quadrant on the right console, the forward portion of the console provides excellent visibility, permitting the location of important and critical visual indications in this area. The wing panels on this console provide additional space for the location of indicators and controls required for certain of the housekeeping operations in the aircraft.

UNCLASSIFIED

The following equipments are located on the right-hand console:

- Master Warning Panel,
- Master Electrical and Engine-Start Panel,
- Armament-Control Panel,
- ARN-6 (Radio-Compass) Control Panel, and
- AIC-10A (Intercom) Control Panel.

The following indicators and controls are located on four wing panels:

- Cabin-Pressure Indicator,
- Oxygen Quantity Indicator,
- Navigation-Light and Defog Switches,
- Alternator Switch and D-C Reset Button,
- Panel and Console Lighting Panel,
- Air-Conditioning Panel including UHF-IFF Emergency Press-to-Test Button, and
- Engine-Air Bleed Panel including PDI Heading Switch.

The layout for this equipment is illustrated in Figure 1. The arrangement follows the order given in the list above, beginning at the front and progressing back along the main console surface to the location of the AIC-10A (Intercom) Control Panel. The remaining equipment is arranged in the same order on the four angled wing panels of this console.

The most critical panel on this console, the master warning panel, is placed forward and at a desirable viewing angle. This allows easy visibility of the indications on this panel. The cabin-pressure and oxygen-quantity indicators are also placed forward, but on the wing panels of this console in a position that allows easy visual inspection of these displays.

The limited amount of prime space on the left console requires that the armament panel be located on the right console. Certain critical functions, such as armament and attack mode selection, arming switch actuation, and launcher retract operation on occasion may have to be performed during critical phases of the mission, and will require removal of the right hand from the control stick momentarily.

The present arrangements of the equipments on the consoles in the pilot's cockpit reflect changes necessitated by the redesign of displays and/or indicated by further human engineering operational studies during the course of the development program. The space allocated for the ARC-555 UIIF control box has been revised in accordance with preliminary information furnished by the RCAF. Space is being reserved on the right-hand console for a C-826 (AIC-10A) control panel if additional audio facilities are needed in the future. The antenna duplexer and the IFF control boxes previously situated in the pilot's cockpit were relocated in the observer's cockpit as they are normally operated by him.

UNCLASSIFIED

2. OBSERVER'S COCKPIT

The rear cockpit of the ARROW (pictured in Figure 2) also consists of a primary panel and right and left consoles which contain controls for the equipment operated by the observer. The front panel in this compartment contains the radar indicator and associated equipment necessary to carry out the primary functions (radar operation and navigation) of the observer.

The consoles along each side of the cockpit contain supporting equipment. There is a hand control for target acquisition, and an armrest mounted on the right side of the cockpit, the latter attached to the airframe above the console.

The consoles in the rear compartment serve a similar function to those found in the pilot's cockpit. They contain the auxiliary controls and indicators necessary for the operation of the primary navigation, communication, and radar equipment used by the observer as well as those necessary for the normal housekeeping operations of the aircraft.

As was the case with the pilot's cockpit, the arrangement of the observer's cockpit was determined through consideration of the mission requirements, the functional association of the several equipments, and their frequency of use. The arrangement is illustrated in Figure 2.

a. Observer's Panel

The front panel in the observer's cockpit includes the instruments and controls listed below:

- Observer's Destination Indicator (ODI),
- Radar and IR-Indicator and Controls,
- Radar and IR Control Panel,
- Range and Range-Rate Meter,
- Altitude Data Counters,
- OBS/AI's Bail-out Command Light, and
- UHF Channel Indicator.

The arrangement of these instruments is illustrated in Figure 2. The radar indicator, because of its importance, is given a central location, which places it in the best visual area. The ODI (observer's destination indicator) is located immediately to the right in a position to facilitate reading the instrument. Its position is dictated to a large degree by the fact that various radar controls are located on the left of the panel. These controls are positioned so that adjustments can be made while viewing the scope and, operating the radar hand control. The remaining instruments showing range and range-rate, command altitude, target altitude, and actual altitude, all of which are functionally related to either the radar display or the navigation display and control, are located near these two display and control groups.

All instruments on the observer's front panel, with the exception of the indicator itself, have been relocated from the configuration shown in the first report. The changes provide better readability of the range and range-rate meter, which is used in conjunction with the indicator, particularly when the target is at close range. Therefore, in the new location, the observer can scan both instruments with only a horizontal eye movement.

UNCLASSIFIED

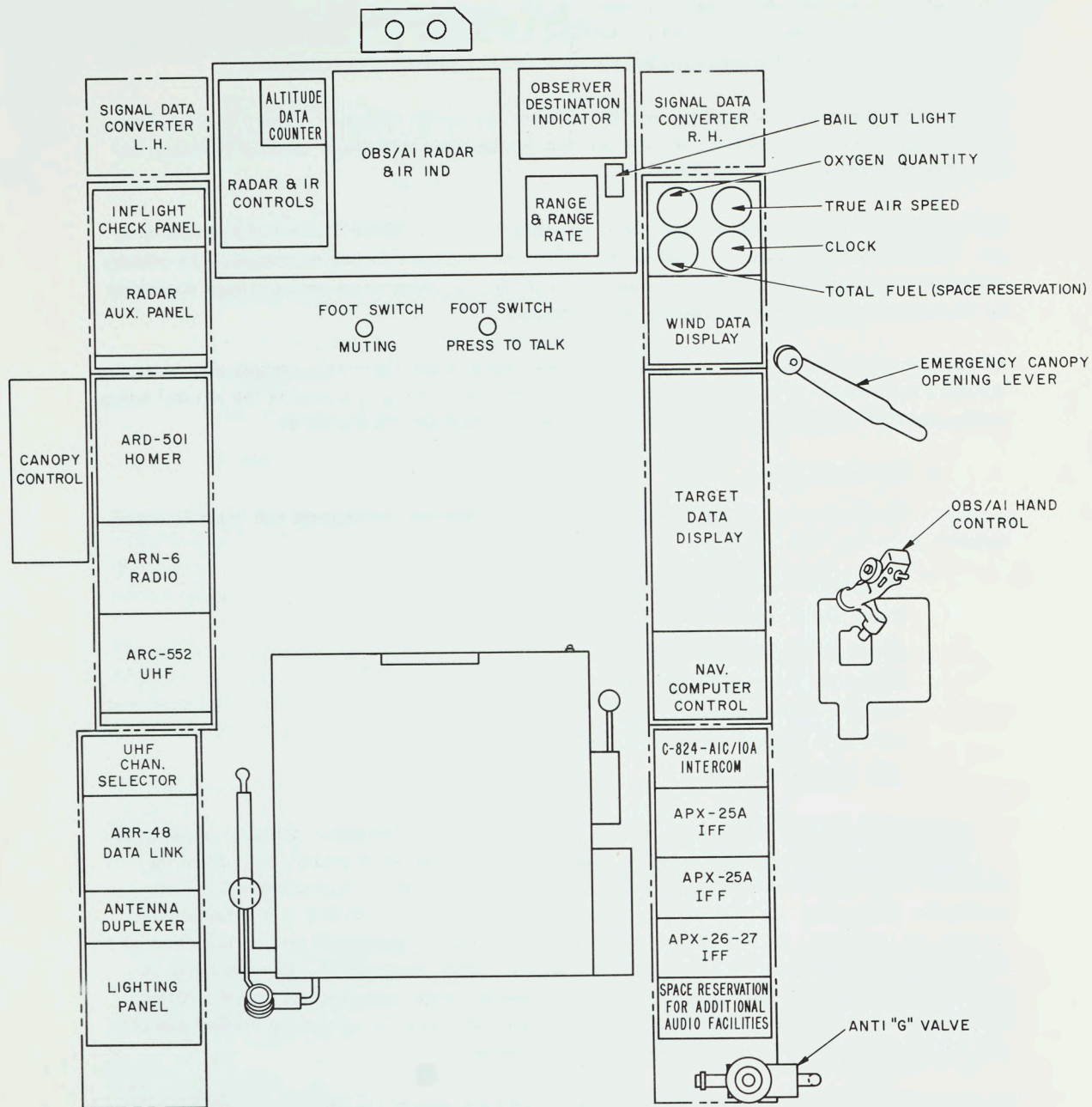

Figure 2. Layout of Observer's Cockpit

UNCLASSIFIED

b. Consoles**1) Right Console**

The predominant items on this console are data and control panels for the navigation equipment. Panels that contain read-outs and require manual control have been placed forward in order to take advantage of the better location and to avoid any difficulty that might have been created by the armrest in operating these items. Those items that require manual control, but have detent positioning stops, have been placed in the more unfavorable location aft of the mid-point of the seat.

The following equipment is located on the right console:

- Clock,
- True Airspeed Counter,
- Total-Fuel Indicator,
- Oxygen-Quantity Indicator,
- Wind-Data Display,
- Target-Data Display,
- Navigation-Computer Control,
- AIC-10A (Intercom) Control Panel,
- APX-25 (IFF) Control Panels, and
- APX-26-27 (IFF) Control Panels.

2) Left Console

The left console contains the communication items and certain controls associated with the radar and ECM operation. Once again, these items have been positioned to facilitate maximum readability and accessibility. Items with detent switches and relative low-frequency of use have been placed alongside and aft of the mid-point of the observer's seat.

At the present writing, definite information on the ARD-501 (ECM Homer), as GFE equipment, is not available. However, space for the ECM Homer Control Box has been reserved on the upper portion of the left console.

The following instruments and controls are located on the left console:

- In-Flight Test Panel,
- Radar Auxiliary Control Panel,
- ARD-501 (ECM) (Homer) Control Panel,
- ARN-6 (Radio Compass) Control Panel,
- ARC-552 (UHF) Control Panel including Control Transfer,
- ARR-48 (Data-Link) Control Panel,

SECRET

Antenna Duplexer, and
Panel and Console Lights Control Panel.

The major change that has been made in the arrangement of the equipments on the observer's consoles was due to the shifting of the APX-25 IFF control boxes from the front to the rear cockpit. The shift was made at the suggestion of the RCAF and as a result of operational studies. Therefore, to locate the APX-25 IFF control boxes in the right hand console, it was necessary to shift the Antenna Duplexer to the left hand console.

SECRET

UNCLASSIFIED

PART II

DETAILED DESCRIPTION
OF DISPLAYS AND CONTROLS

SECRET

A. PILOT'S PANEL

1. PILOT'S RADAR INDICATOR AND CONTROLS

a. Radar Displays

The pilot's indicator Figure 3, which shows attack information only presents an osciloscopic display of aircraft attitude, steering error, and time-to-fire. A description of the various displays follows:

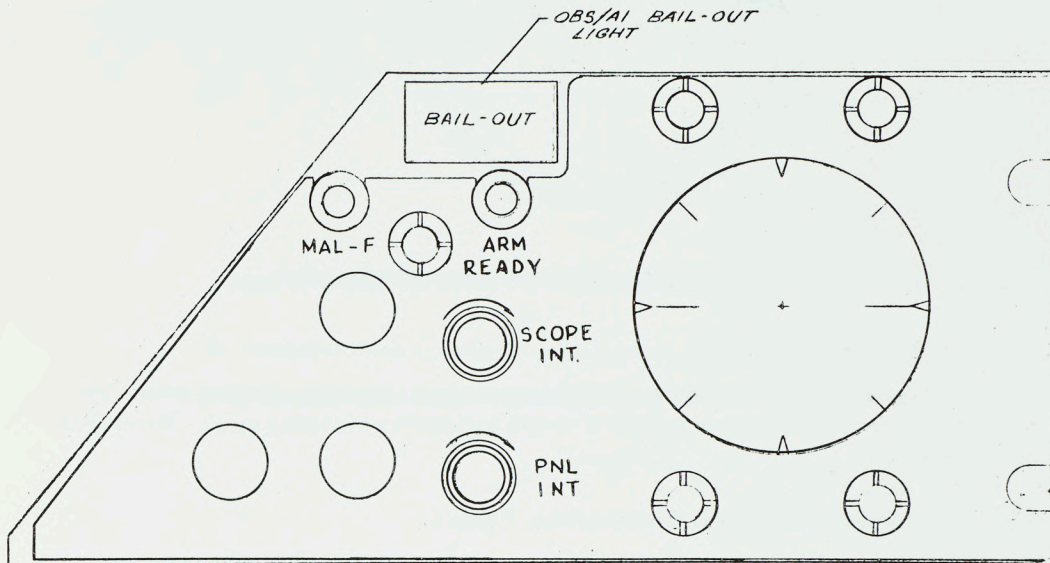

Figure 3. Pilot's Indicator and Controls

1) Lead-Collision Rocket Attack

Figure 4 shows the pilot's display during a lead-collision rocket attack.

a) Artificial Horizon

The vertical translation of the artificial horizon corresponds to the aircraft elevation angle. The roll of the artificial horizon is of the opposite sense to the roll of the aircraft. Roll and elevation angles are supplied by the platform repeater.

b) Time Arc

The time arc represents the time remaining before firing ($T - T_f$). The scale factor is 4.5 degrees/sec.

c) Steering Dot

The steering dot represents the total steering error in radar coordinates with a sensitivity of 4 degrees/inch.

SECRET
UNCLASSIFIED

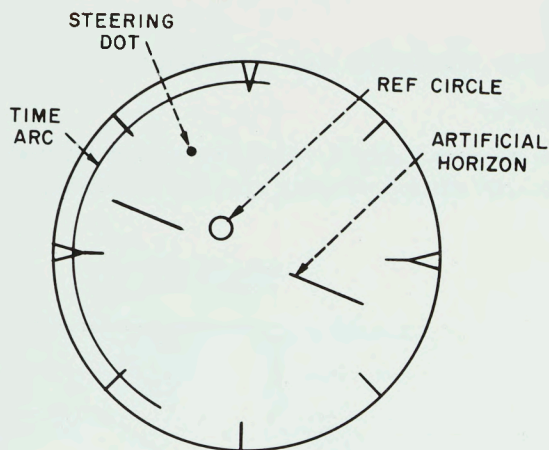

Figure 4. Display for a Lead-Collision Attack with Rockets

d) *Reference Circle*

The radius of the reference circle represents a 1/2-degree steering error. The center of the reference circle moves to provide a coarse indication of steering error. The sensitivity is 20 degrees/inch.

2) *Lead-Collision Snap Up, Rocket Attack, Phase I*

A snap-up attack consists of two distinct phases. In Phase I (display shown in Figure 5) the interceptor corrects only the horizontal component of the total steering error. Phase II is initiated by either the fire-control computer or by the pilot's snap-up reject switch. In Phase II, the interceptor climbs to zero the elevation steering error prior to launching the weapons.

In the Phase I, lead-collision, snap-up, rocket attack the display is the same given above for lead-collision rocket with the following exceptions:

a) *Steering Dat*

The steering dot represents the horizontal component of the steering error with a sensitivity of 4 degrees/inch.

b) *Reference Circle*

The reference circle is elongated vertically to indicate snap-up. The center of the ellipse moves to indicate the horizontal component of steering error with a sensitivity of 20 degrees/inch.

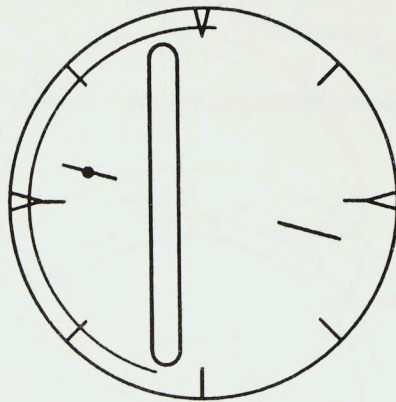

Figure 5. Display for Phase I of a Lead-Collision Snap-Up Attack with Rackets

3) Lead-Collision Snap-Up, Racket Attack, Phase II

The display in Phase II is the same as for a lead-collision rocket attack.

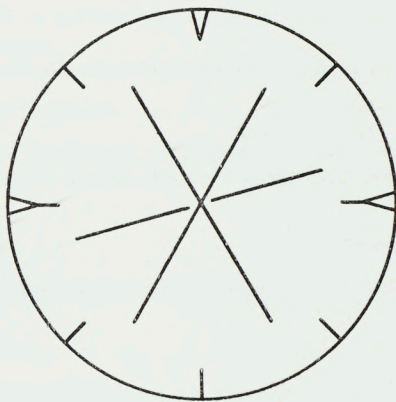

Figure 6. Display for Breakaway Rocket

4) Breakaway Display Rocket

The display is shown in Figure 6 and is described below.

a) Artificial Horizon

The artificial horizon is the same as for a lead-collision rocket attack.

b) Steering Dot

The steering dot is the same as for a Lead-Collision rocket attack.

c) Breakaway X

An "X" appears instructing the pilot to break off the attack.

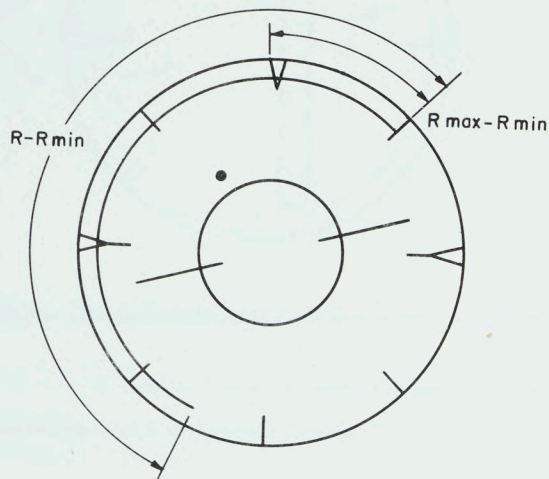

Figure 7. Display for Lead-Pursuit Missile Attack

5) Lead-Pursuit, Missile Attack

The display for a lead-pursuit missile attack (Figure 7) is described below.

a) Artificial Horizon

The artificial horizon is the same as for a lead-collision rocket attack.

b) Steering Dot

The steering dot represents the total steering error in antenna coordinates. It has a sensitivity of 20 degrees/inch.

c) Range Arc

The range-to-fire is indicated by an arc along the outer periphery of the tube face. The length of the arc indicates the range to the minimum launching distance (R_{min}), and the permissible launching range is indicated by the positioning of the arc. The length of arc shown counterclockwise from the 12 o'clock position indicates the range to the maximum launching distance (R_{max}). The length of arc shown clockwise beyond the 12 o'clock position represents the permissible launch range ($R_{max}-R_{min}$). The scale factor is 4.5 degree/thousand yards.

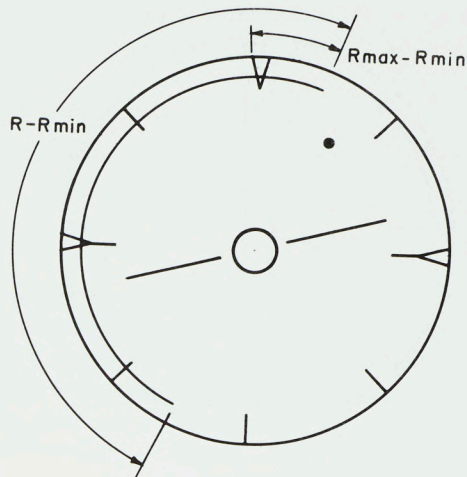

Figure 8. Display for Lead-Collision Missile Attack

d) *Reference Circle*

The center of the reference circle is fixed. The diameter of the circle represents allowable steering error and varies as a function of pressure ratio between approximately 10 degrees and 30 degrees of steering error.

6) *Lead-Collision Missile Attack*

The display for a lead-collision missile attack is described below. Figure 8 shows the display.

a) *Artificial Horizon*

The artificial horizon is the same as in the lead-collision rocket attack.

b) *Steering Dot*

The steering dot represents the total steering error in antenna coordinates with a sensitivity of 20 degrees/inch.

c) *Range Arc*

The range arc is the same as in lead-pursuit, missile attack.

d) *Reference Circle*

The center and radius of the reference circle are fixed. The radius of the circle represents $2\frac{1}{2}$ degrees of steering error with a scale factor of 20 degrees/inch.

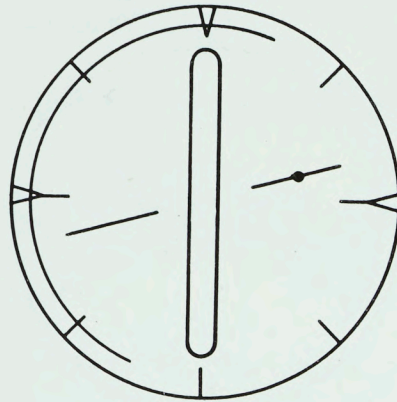

Figure 9. Display for Lead-Collision Snap-Up, Missile Attack, Phase I

7) Lead-Collision Snap-Up, Missile Attack, Phase I

The display (Figure 9) is the same as for a lead-collision, missile attack with the following exceptions:

a) Steering Dot

The steering dot represents the horizontal component only of the steering error. The sensitivity is 20 degrees/inch.

b) Reference Circle

The reference circle is elongated vertically to indicate to the pilot that he is in Phase I of Snap-Up.

8) Lead-Collision Snap-Up, Missile Attack, Phase II

The display in Phase II is the same as for a lead-collision, missile attack as shown in Figure 8.

9) Breakaway, Missile

The display for breakaway from a missile attack is the same as the breakaway indication for a rocket attack and is shown in Figure 6.

b. Cathode Ray Tube

The pilot's cathode ray tube is a single-gun, 3-inch, high-intensity tube that uses electrostatic deflection and focus. The power supply is integrally mounted with the tube. A Plexiglas overlay is provided with lighted markings to aid in interpretation of the displays.

c. Scope Intensity Control

The scope intensity control is used to change the intensity of the pilot's radar display to suit the ambient light conditions and personal preferences.

d. Panel Intensity Control

The panel intensity control sets the brightness of the grid overlay lines on the pilot's radar indicator and of the panel lights.

2. MASTER WARNING LIGHTS

Red and amber master warning lights (Figure 1), are situated to the right of the pilot's scope. These lights are attention-getters. The red master warning light indicates "fire" only. The pilot, seeing this light energized, refers to the relevant illuminated fire button on the left console. The amber master warning light gives warning of other failures, caution or selected conditions. The pilot seeing this light energized, refers to the warning-information panel forward on the starboard console for detailed information. The two master warning lights can be reset to accept further signals by pressing a reset switch at the aft end of the warning information panel. The warning information panel will retain any signal until the fault is cleared.

The information panel warnings are grouped vertically according to systems and left or right according to the direction of the failed component (Figure 37). The vertical separation between system is shown by horizontal white lines.

Failure of both flying-control hydraulic systems (A and B) is shown by energizing a separate red section of both the A- and B-warning labels on the information panel. Otherwise all the information panel warnings are colored amber.

A green light located to the left of the indicator will indicate when the pilot has activated the observer bail-out switch. This light goes out when the observer has ejected.

3. INDICATED AIRSPEED METER

The airspeed indicator, Figure 10, is a pitot static-operated airspeed device that shows the actual indicated airspeed at which the plane can be flown.

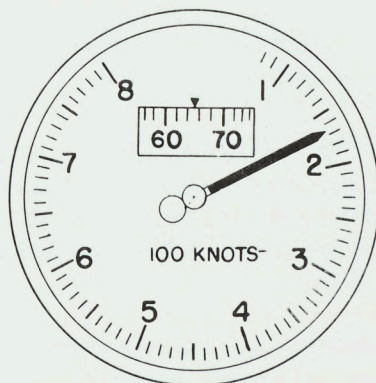

Figure 10. Indicated Airspeed Meter

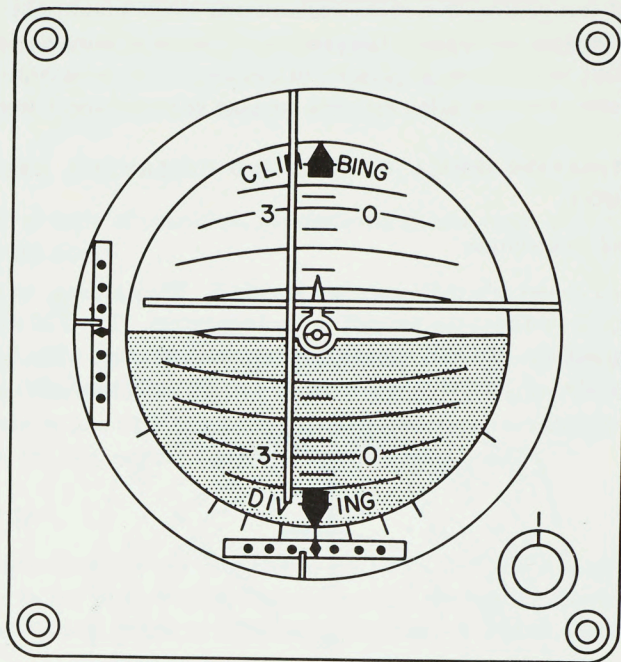

Figure 12. Flight Director/Attitude Indicator

Elevation and roll indications are continuously displayed by means of a "two-toned" sphere that is gimballed to follow signals from the stable platform. The top half of the ball is colored a light grey to represent the sky and the bottom half is colored a dark grey color to represent the earth. The sphere is marked with elevation-angle graduations that are read against a fixed aircraft symbol. The bank-angle scale is placed at the bottom of the indicator for better visibility and proper sensing of the roll pointer. The pointer moves to the right when the aircraft banks right.

The flight director/attitude indicator provides the pilot with AGCA steering information by means of horizontal and vertical director needles, the pilot flying the aircraft so as to center the needles on the miniature aircraft symbol. The director needles are actuated by data-link signals.

The smaller pointers are deviation indicators. The AGCA signals from the data link are fed directly to the meters to indicate displacement errors with no rate involved. The azimuth pointer is located at 6 o'clock on the instrument face and the glide slope pointer is located at 9 o'clock.

The indicator will have three-axis capability in that the top half of the sphere will be driven by azimuth signals from the stable platform.

No azimuth scale will be provided since this information is available on the pilot's destination indicator.

Use of the three-axis sphere will provide the pilot with more realistic attitude indication during all parts of any maneuver. A display employing a sphere free to rotate about only two axes would be difficult to interpret in certain attitudes attainable in a high-performance interceptor.

For indicated airspeed a vernier scale on a drum is provided which is visible through a window at the top center of the main dial. Graduations are provided for each 2 knots and estimates within 1/2 knot can be made.

4. MACH INDICATOR

The Mach indicator (Figure 11) presents Mach, command Mach, and Mach limit by means of servo-positioned pointers traveling along a horizontal scale.

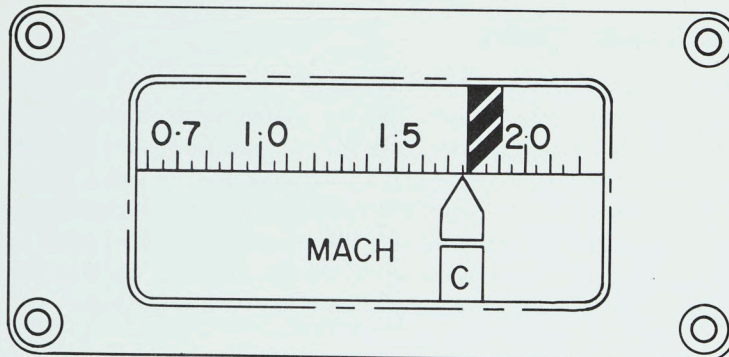

Figure 11. Mach Indicator

The Mach indicator has a range from 0.60 to 2.2 Mach. The indicating pointer travels below the base line of the scale, which has graduations every 0.05 Mach. The command Mach pointer travels below the Mach pointer and is designed so that the Mach pointer can be aligned precisely with it. The command Mach pointer is driven off scale when command information is not available from data link.

The Mach limit bar may travel from 1.1 to 2.0 Mach, the limit itself being determined by skin temperature and/or structural limitations of the aircraft. The bar is distinguished by red and yellow stripes.

The signals for Mach and Mach limit come from the air-data computer. The command Mach signal comes from the ground control via data link. The repeater accuracy of the three Mach signal channels is ± 0.02 Mach. The slewing speed of the pointers is 9 Mach/minute, which is more than adequate to prevent lag between actual aircraft speed and indication during acceleration. The Mach indicator has integral lighting, and a hermetically sealed case.

5. FLIGHT DIRECTOR/ATTITUDE INDICATOR

The flight director/attitude indicator (Figure 12) provides a "moving-horizon" type of aircraft attitude to the pilot through 360 degrees in elevation and roll. The instrument also provides horizontal and vertical steering information and displacements from glide-slope and runway reference when operating in the AGCA Mode.

An important feature of this display is a small knob located in the lower right corner of the indicator face to permit electrical pitch trim. The electrical pitch trim provides up to 20 degrees dive trim and 10 degrees climb trim, allowing the pilot to trim the sphere so that the horizon line is directly behind the miniature airplane in a continued nose-up or nose-down attitude.

6. PILOT'S DESTINATION INDICATOR (PDI) AND OBSERVER'S DESTINATION INDICATOR (ODI)

a. Function and Description

The pilot and observer's indicators are identical. They present an integrated display of all indications required to direct the aircraft to its destination. The PDI will normally display magnetic heading, whereas the ODI will normally display grid heading. The bearing switch on the main panel allows selection of Normal, UHF ADF, or LF/MF ADF displays. Figure 13 shows the destination indicator.

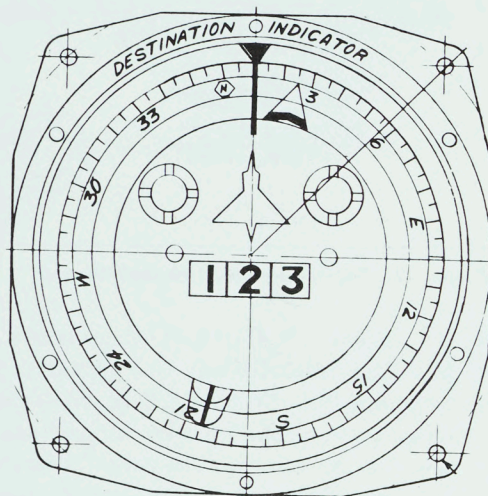

Figure 13. Destination Indicator

b. Normal Display

The normal display is used for interception, navigation and data-link modes.

The stationary vertical pointer indicates the aircraft heading when read against the moving compass card, the moving pointer indicates the bearing of the target or destination when read against the moving compass card, and the bug provides command heading information when read against the moving compass card. The aircraft is flown so that the bug coincides with the stationary pointer. (The bug indicates the command heading, which is brought to the 12 o'clock reference position.) The distance counter presents the distance from the aircraft to the target or destination.

There is no difference in display between navigation to a stationary point and navigation to intercept a moving target.

c. ADF Display

On selection of UHF ADF or LF/MF ADF, the moving pointer indicates the bearing of the source of transmission. The distance display is blanked out; all other indications remain as in the normal mode.

7. PILOT'S DESTINATION-INDICATOR BEARING CONTROL

The pilot's destination-indicator bearing control (Figure 14) enables the pilot to select UHF ADF, LF/MF ADF or navigation computer information to be displayed on the pilot's destination indicator. The positions and their functions are as follows:

a. Normal

In the normal mode of operation, the indicator displays are as discussed under the pilot's destination indicator.

b. UHF/ADF

In the UHF/ADF mode the PDI is connected to the ARA-25 Direction Finder. The bearing pointer on the PDI indicates bearing to the transmitting station. Selection of the transmitting station is made on the UHF transceiver or data-link receiver controls. A flag will obscure the distance counter; the bug signals remain as in the normal mode.

c. LF/MF ADF

The indicator displays are the same as for UHF/ADF given in (2) above, except that the PDI is connected to the ARN-6 radio compass so that the bearing pointer on the PDI shows the bearing to the transmitter, which is selected on the ARN-6 control panel.

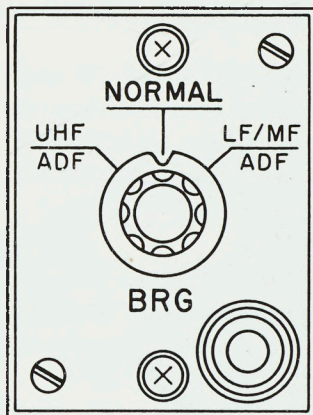

Figure 14. Pilot's Destination-Indicator Bearing Control

8. ALTIMETER

The function of the altimeter (Figure 15) is to display the actual pressure altitude of the aircraft. The instrument operates directly from a static pressure input. A diaphragm arrangement expands and contracts with static pressure changes. The driving mechanism for the display needle and counter is geared to record the motion of the diaphragm. The instrument, which reads in feet, is equipped with a manual correction mechanism to adjust the scale reading for changes in barometric pressure.

UNCLASSIFIED

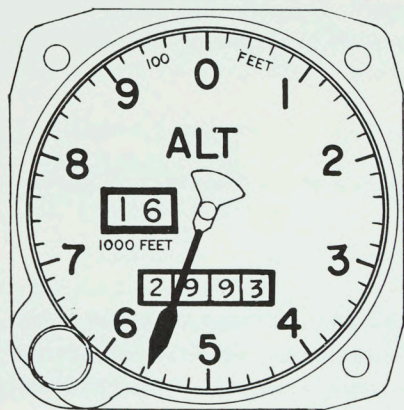

Figure 15. Altimeter

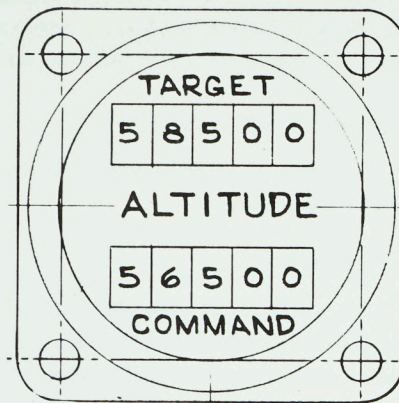

Figure 16. Command- and Target-Altitude Counter

9. COMMAND- AND TARGET-ALTITUDE COUNTER (PILOT)

The information displayed to the pilot by the altitude-data counters shown in Figure 16 is furnished either by the ground environment or by the observer. These counters repeat from the observer altitude counters, which are either following up ground environment data or are slewed by the observer.

This instrument consists of two servo-driven drum indicators, one for each of the two altitude functions. Target and command altitude readouts are in hundreds of feet with fixed zeros for the last two digits. The instrument is integrally lit and hermetically sealed.

10. RATE-OF-CLIMB INDICATOR

The Rate-of-Climb Indicator (Figure 17) shows the rate of change of altitude. It indicates the correct rate of ascent or descent during take-off or landing and is used as an aid in maintaining level flight. The indicator is actuated by the static pressure transmitted by the pitot static tube and is integrally lit.

11. ENGINE PERFORMANCE INDICATOR

Each engine performance indicator of Figure 18 (one EPI per engine) presents information on the percent of total thrust being used. Engine thrust is indicated by the "MIL" bug (military power) up to 100 percent.

Afterburner thrust is indicated by the "A/B" bug which appears when afterburner has been selected.

Engine overtemperature caution range is indicated by the shaded portion of the temperature scale (750-950 °C). Each engine is instrumented individually.

UNCLASSIFIED

12. FUEL QUANTITY METER

The fuel quantity meter (Figure 19) is motor-driven; it contains a transistor amplifier, a bridge circuit, and a power supply in a common package. The meter indicates fuel quantity by



Figure 17. Rate-of-Climb Indicator

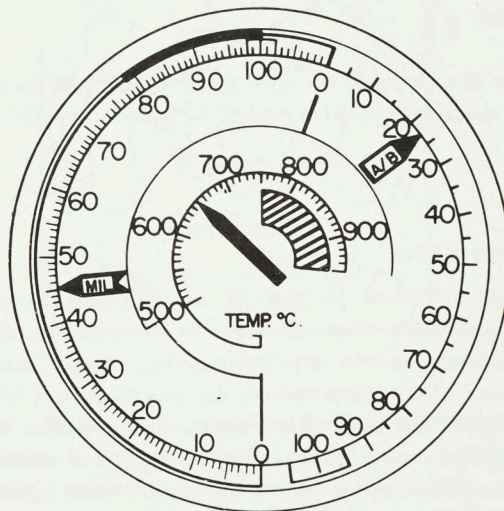

Figure 18. Engine Performance Indicator

means of a pointer display. Integral lighting of the display is provided, and the instrument is hermetically sealed. System calibration adjustments are provided on the back plate. Two such meters are provided for independent gaging fuel in the right and left fuel systems. The information supplied to the pilot is fuel quantity in pounds; the information is corrected for deviations in the capacitive index of the fuel from the nominal value, due to temperature, types of fuels, and variations within a type. Minor meter graduations mark off each 500 pounds.



Figure 19. Fuel Quantity Meter

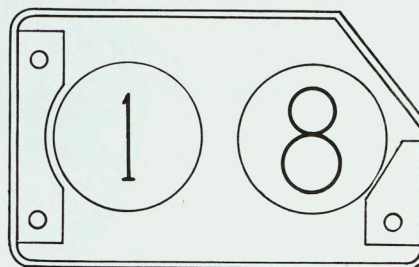

Figure 20. UHF Channel Indicator

13. UHF CHANNEL INDICATOR

A UHF Channel Indicator (Figure 20) is mounted in both cockpits to provide channel indication to both crew members. The indicator consists of two Nixie tubes which present a two-digit display of the channel to which the UHF Command Transceiver is actually set. In addition to displaying the preset channel numbers, facility is provided to display "G" or "M" indicating guard or a manually set frequency.

Prior to the selection of a new channel, the crew member must take over control of the ARC-552 Transceiver by operating the active-passive switch located on the ARC-552 Control Panels (Figures 28 and 51).

14. OPTICAL SIGHT

a. Function and Description

The optical sight will be of the fixed reticle collimating type. It will be mounted under the windscreen frame of the aircraft. The sight head will contain the necessary optics including the light source, condenser lens, reticle, adjustable mirror, window, mangin mirror, and combining glass. Although it will use a single light source, the optical system will be binocular to enable sighting around the center structure in the windscreen. Two identical reticles will be illuminated by the single lamp through condensing lenses. Fixed mirrors will direct the light through the combining glass to the mangin mirrors, which reflect the bright reticle images to the combining glass. The pilot will see one reticle image with the right eye and the other with the left eye. The fused image will appear to be at infinity. The design of the sight incorporating the features desired by the RCAF is not yet complete.

b. Combining Glass

The combining glass will be mounted in such a manner as to "fold-down" to a horizontal position out of the pilot's field of vision when not in use. This will provide an unobstructed "over-the-nose" vision of 13 deg downward as viewed from the pilot's normal eye position. When required, the combining glass can be quickly snapped into its operational position.

c. Dimmer Control

A dual dimmer control with a center Off position will be provided to regulate smoothly the reticle intensity from the maximum value down to zero with either of the two lamp filaments.

15. MISCELLANEOUS INDICATORS AND INSTRUMENTS

All flight instruments are being lettered in accordance with ABC Air Standard 13/6.

Additional panel mounted devices whose functions are self explanatory are:

- (a) Landing gear position indicator (Figure 21),
- (b) Turn and slip indicator (Figure 22),
- (c) Accelerometer (Figure 23),
- (d) G-Trim Indicator (Figure 24), and
- (e) Elapsed Time Clock (Figure 25).

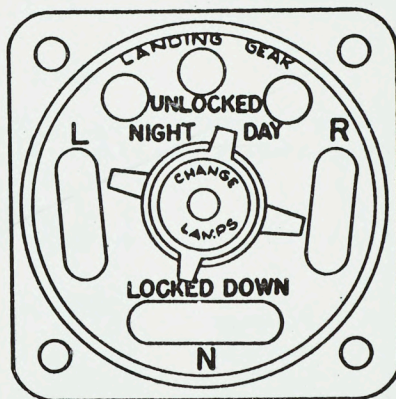

Figure 21. Landing-Gear Position Indicator

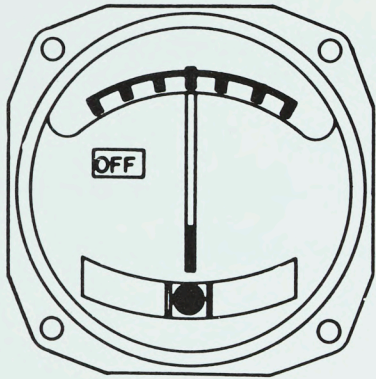

Figure 22. Turn and Slip Indicator

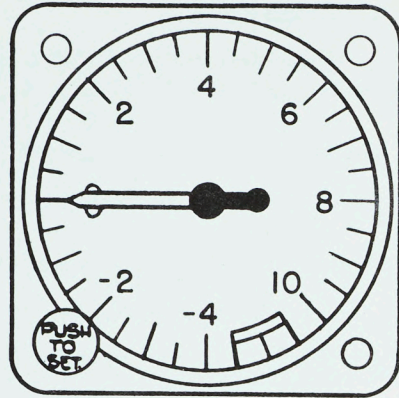

Figure 23. Accelerometer

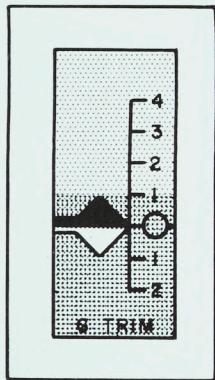

Figure 24. G-trim Indicator

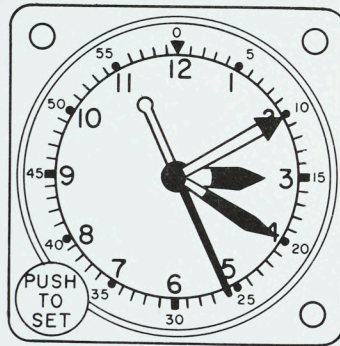

Figure 25. Clock

B. PILOT'S CONSOLES

1. AFCS CONTROL PANEL

The AFCS function-selector panel (Figure 26) is manually switched to the desired operating mode of the aircraft while flying on AFCS.

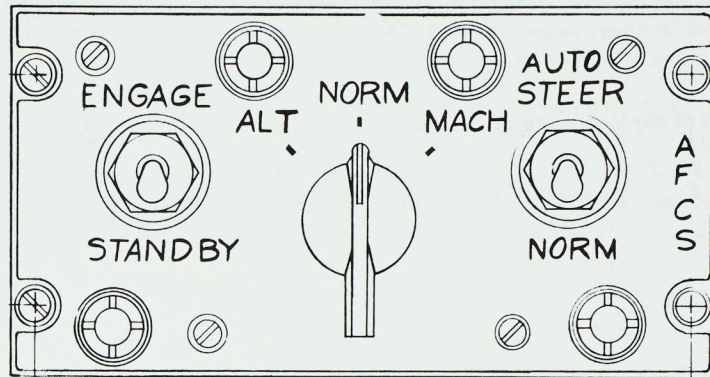

Figure 26. AFCS Control Panel

The engage/standby switch controls the input signal to the damper system. When in engage position, the damper is provided with attitude-hold signals unless auto-steer signals from the coupler have been selected by the auto-steer/norm switch. The altitude/normal/Mach switch selects either altitude hold or Mach hold signals from the air-data computer. Its switches are held in the energized position by solenoids and are spring loaded to the normal or standby position.

2. DAMPER CONTROL PANEL

The damper function-selector panel (Figure 27) provides a means for turning on the damper system, engaging servos, and switching to an emergency mode.

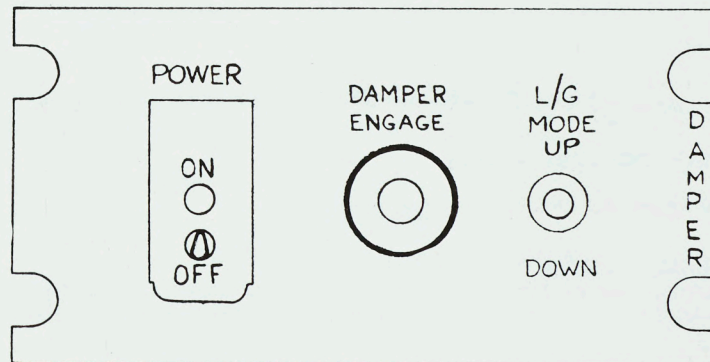

Figure 27. Damper Control Panel

When the power switch is in the on position, the system is in a standby mode with all power supplied except servo engage power. A guard is provided so that the pilot cannot inadvertently throw the switch to off.

Pushing the engage button activates and engages the damper system. A toggle switch is located adjacent to the damper engage button for manual selection of gear mode. Another switch is located on the oxygen and fuel test panel to check the gear-up mode while on the ground. Any malfunction will be indicated by a light on the warning panel.

3. ARC-552 (UHF) CONTROL PANEL

An ARC-552 control panel (Figure 28) is provided in both the pilot's and observer's cockpits. The pilot's control is functionally identical with the observer's control except that the manual frequency setting dials have been omitted. The switch functions are explained later in the discussion of the observer's controls.

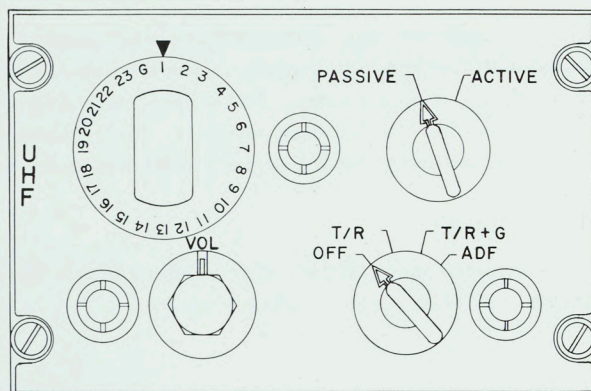

Figure 28. ARC-552 UHF Control Panel (Pilot)

4. ARMAMENT CONTROL PANEL

Figure 29 shows the armament control panel.

a. Attack Mode Selector

The attack-mode rotary selector switch provides for selection of five flight modes, as described below.

1) Reject Snap-Up

The reject snap-up position permits the pilot to reject the snap-up attack mode. If the differential altitude exceeds 20,000 feet or if the interceptor altitude exceeds 50,000 feet, the

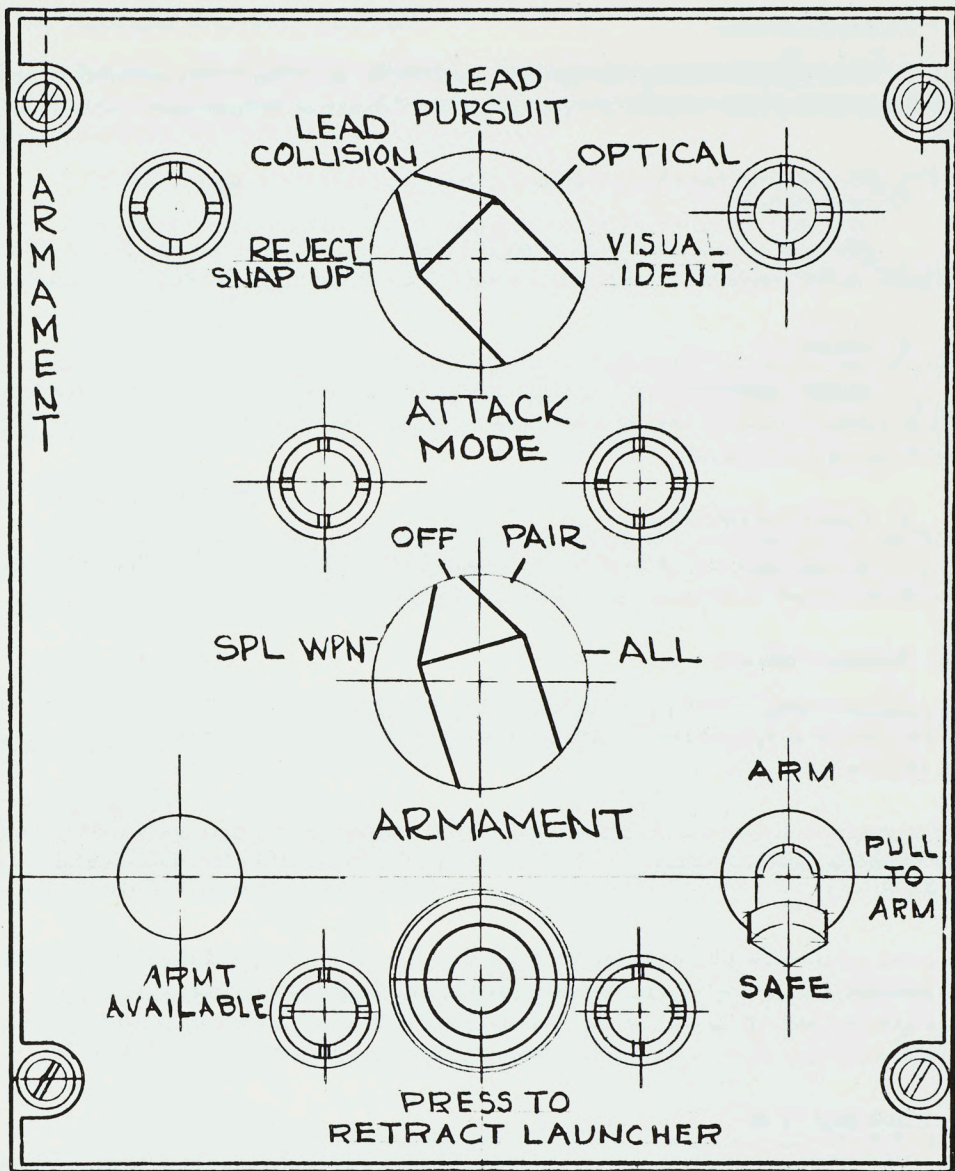

Figure 29. Armament Control Panel

snap-up mode is automatically chosen by the computer. If the tactical situation precludes the use of this automatically selected mode, activation of the reject snap-up position returns the computer to a coplanar attack. This switch position is spring loaded to return to the lead-collision position.

2) Lead-Collision

The lead-collision switch position provides for launching either missiles or rockets. Armament firing can be either manual or automatic using the manual firing trigger switch as an interlock.

3) Lead-Pursuit

The lead-pursuit position is employed only for launching missiles. Firing of the missile can be either manual or automatic using the manual firing trigger switch as an interlock.

4) Optical

Optical sighting is used during periods of radar failure or jamming when the armament will be directed using an optical non-computing sight. Only missiles may be fired in this mode and firing must be manual.

5) Visual Identification

No armament can be fired in the visual identification mode. The pilot will be visually searching for the target at an appropriate bearing supplied by the observer.

b. Armament Selector

The armament selector permits the pilot to select the armament to be used during an attack. The armament selector switch has the following position designations in the order stated: Spl Wpn, Off, Pair, and All.

When the armament selector switch is thrown to special weapons, the lead-pursuit voltage to the computer is broken, thereby placing the computer in either a lead-collision or lead-collision snap-up mode.

The armament selector switch, when thrown to pair or all, will initiate condition I in the missiles, and will connect primary power to the missile auxiliaries. In the pair position, the forward launchers are selected. In the all position, forward and rear launchers are selected for lowering, and pair selection is maintained thereafter without interruption during switching to all.

c. Safe-Arm Switch

The safe-arm switch allows the pilot to manually arm or disarm the weapons. The safe-arm switch is a double-pole, single-throw switch that serves as a firing interlock for all weapons and must be thrown to arm when firing in either manual or automatic modes. To select the arm position the toggle must be pulled out approximately 1/8-inch. The switch can be returned to the safe position without pulling the toggle.

UNCLASSIFIED

d. Launcher Retract Button

The launcher retract button permits manual retraction of the launchers into the armament bay. This button is mounted in a recessed cup to prevent inadvertent actuation

e. Armament Availability Indicator

The armament availability indicator, a three-position mechanical flag, shows the pilot whether armament is available in any of the positions selected by the armament selector switch. The availability indicator has the following notations:

- (1) "A" flag denotes that armament is available in the position selected by the pilot.
- (2) "N.A." flag denotes that armament is not available in this position.
- (3) Crosshatched flag  indicates to the pilot that he has failed to throw the safe-arm switch.

These notations are based on the following assumptions: 1) the pilot knows before takeoff the weapon that is aboard the aircraft and 2) there will never be a mixed load of weapons, i.e., two Sparrow and two MB-1's.

5. STORES JETTISON

The stores jettison button as shown in Figure 30 is located near the throttle quadrant on the left-hand console. It is an emergency button that jettisons the missiles and the external tank. The jettison procedure is as follows.

a. Normal Flight

When all gas is consumed, the pilot can jettison the external tank by depressing the external-tank jettison button located on the fire, fuel, and trim control panel.

b. Failure

In the event of failure of the pushbutton on the fire, fuel, and trim control panel, the pilot can jettison the external tank by means of a manual release located over the parking brake.

c. Automatic

If the external tank has not been previously jettisoned, it is automatically jettisoned when armament is lowered.

d. Hangfire

In the event of missile hangfire, all power is removed from the extended missile, and it will be manually retracted by the pilot.

6. ARN-6 (RADIO COMPASS) CONTROL PANEL**a. Function and Description**

The control box C-1513/ARN-6 shown in Figure 31 provides complete remote control of the ARN-6 radio compass. The radio compass may be controlled from either of the identical control boxes that are located in each cockpit.

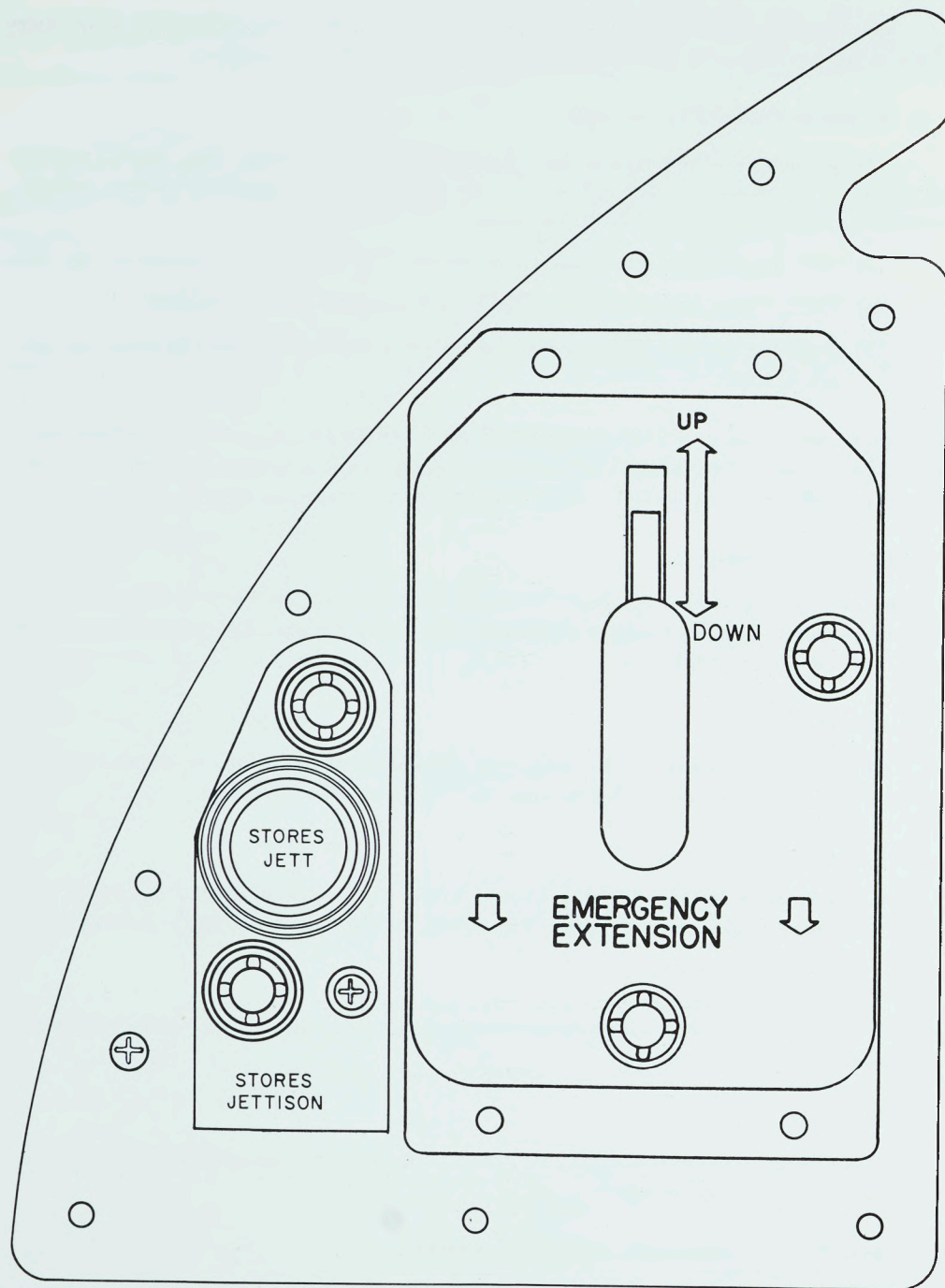

Figure 30. Landing-Gear Control and Stores Jettison Button

b. Function Switch

The function switch permits selection of the following modes of operation: ADF, ANT, LOOP, and CONT.

1) ADF

In the ADF switch position the radio compass will supply continuous bearing information with respect to a given station.

2) ANT

The ant switch position permits reception by means of a non-directional antenna.

3) LOOP

Directional reception of a station may be accomplished in the loop mode by varying its position with the loop, L-R switch for maximum signal strength.

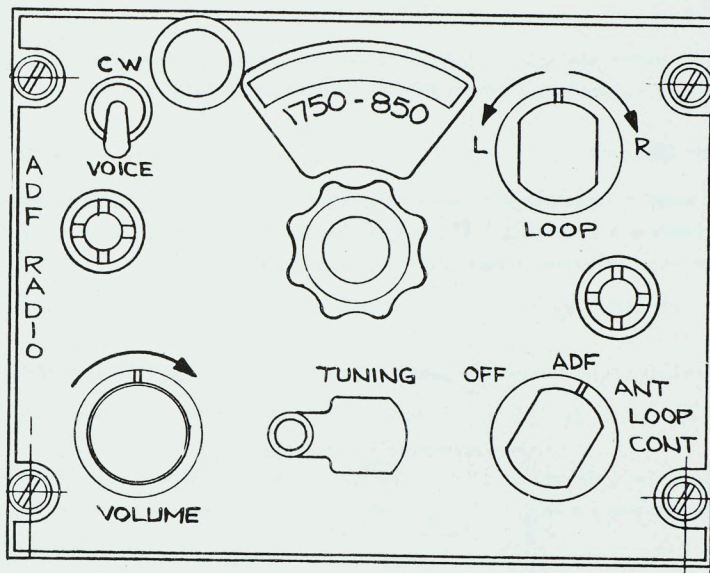

Figure 31. ARN-6 Control Panel

4) CONT

The cont position is spring loaded for momentary contact, it switches control of the radio compass to the control box in which the button is pressed.

c. CW-Voice Switch

The CW-Voice switch allows reception of either modulated or unmodulated signals.

d. **Bandswitch**

Rotation of the bandswitch changes the bank of frequencies in which operation is desired.

e. **Volume**

The level of audio signals may be varied with the volume control.

7. PILOT'S DESTINATION-INDICATOR HEADING CONTROL

The heading control, Figure 32, located on the engine-air bleed panel, provides heading switching to the moving card on the PDI. It permits the pilot to obtain an emergency magnetic heading display in the event of stable platform failure. It also permits him to obtain a grid heading display from the stable platform. Should the pilot require a magnetic heading in the event of flux valve failure, he may switch the heading switch to magnetic (normal), provided that the observer has manually set in grivation on the wind-data display. The designations of the positions and their functions are:-

a. **Flux Valve**

The flux valve position is for use when the stable platform fails. A magnetic signal obtained from the flux valve is fed to the PDI and also to the ODI.

b. **Magnetic (Normal)**

The magnetic (normal) position is the normal operational position when stable platform and flux valve signals are available. The signal fed to the PDI is the sum of grid heading (from the stable platform) and grivation (from the wind-data display).

c. **Grid**

Grid heading (from the stable platform) is fed to both the PDI and ODI Compass cards.

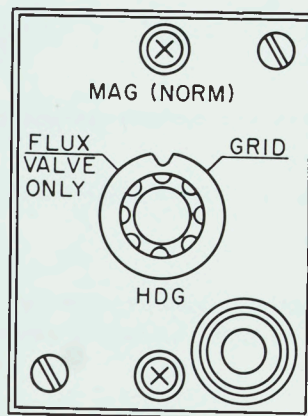

Figure 32. Pilot's Destination-Indicator Heading Control

UNCLASSIFIED

8. AIC-10A (INTERCOM) CONTROL PANEL

a. Function and Description

Identical control panels for the intercommunications set are mounted in both the pilot's and observer's cockpits. They are located in approximately the same relative position, i.e., on the right-hand console in each cockpit. Controls on both panels perform the same function. Space is being reserved for a C-826 control which, if inserted, will provide facilities for ECM homer and spares for future audio facilities.

b. Mixing Switches

Five toggle switches across the top of the C-824 Control Panel (Figure 33) provide a means of mixing and selecting audio input circuits. The following are the functions of the mixing switches as viewed left to right.

1) INTER

Provides interphone between the pilot and observer.

2) COMP

Provides aural reception of the ARN-6 Radio Compass.

3) COMM

Provides reception of the ARC-552 receiver audio.

4) Data

Provides aural reception from the data-link receiver, ARR-48.

5) Radar Output

Provides aural reception of ECM signals via the fire-control radar receiver.

A rotary channel selector switch on the C-824 is used for connecting input and output circuits as selected, and connects control circuits for talk operation. Positions on the rotary selector are Call, Inter, Comm, and Tel.

c. Normal-Aux

The normal-auxiliary switch is wire locked in the Normal position. In the event of amplifier failure, emergency interphone listening may be obtained by breaking the wire-locking and switching to Aux. Listen. In this position, the amplifier is by-passed and the headset is connected to the interphone line. Mixing is inoperative in this position.

d. Volume Control

The Vol control in the control panel is the master control that varies the audio level of all incoming channels.

9. PANEL AND CONSOLE-LIGHTS CONTROL PANEL

One control panel (Figure 34) is located in each cockpit for the purpose of controlling the light intensity of the panel- and console-mounted instruments and control boxes. All integrally lighted, independent instruments will have five-volt systems in accordance with MIL-L-25467A. All edge-lighted panels will have 28-volt systems in accordance with MIL-P-7788. Spare lamp bulbs will not be furnished.

Three potentiometers, mounted on the panel, control the brightness of lights on the main panel, the console panels, and the console floodlights, respectively.

10. OTHER CONSOLE CONTROLS

Functions of the following controls mounted on the pilot's consoles are self-explanatory:

- (a) Figure 30, Landing-Gear Control and Stores Jettison,
- (b) Figure 35, Fuel, Fire, and Trim Controls,
- (c) Figure 36, Control-Surface Position Indicator,
- (d) Figure 37, Warning Panel,
- (e) Figure 38, Master Electrical Panel,
- (f) Figure 39, Oxygen Indicator and Miscellaneous Controls,
- (g) Figure 40, Air-Conditioning Panel including UHF/IFF Emergency, Press-to-Test,
- (h) Figure 41, Circuit Breaker Panel,
- (i) Figure 42, Canopy Switch Panel,
- (j) Figure 43, Engine Air Bleed Panel, and
- (k) Figure 44, Fuel and Oxygen Test Panel.

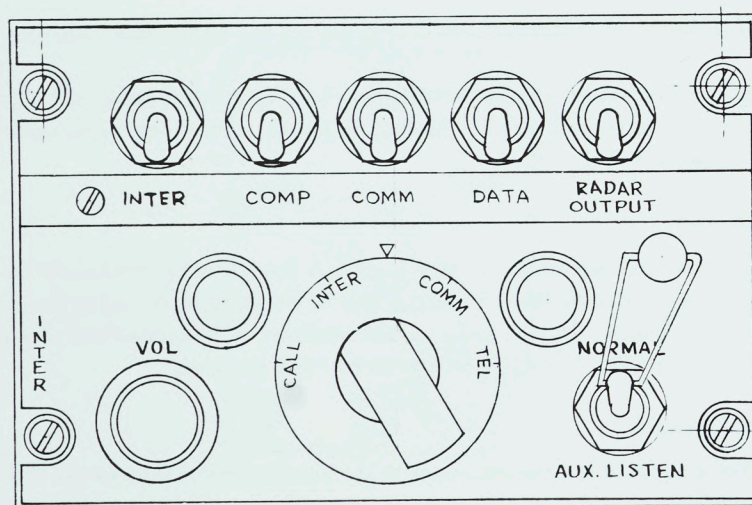

Figure 33. AIC-10A (C-824) Intercom Control Panel

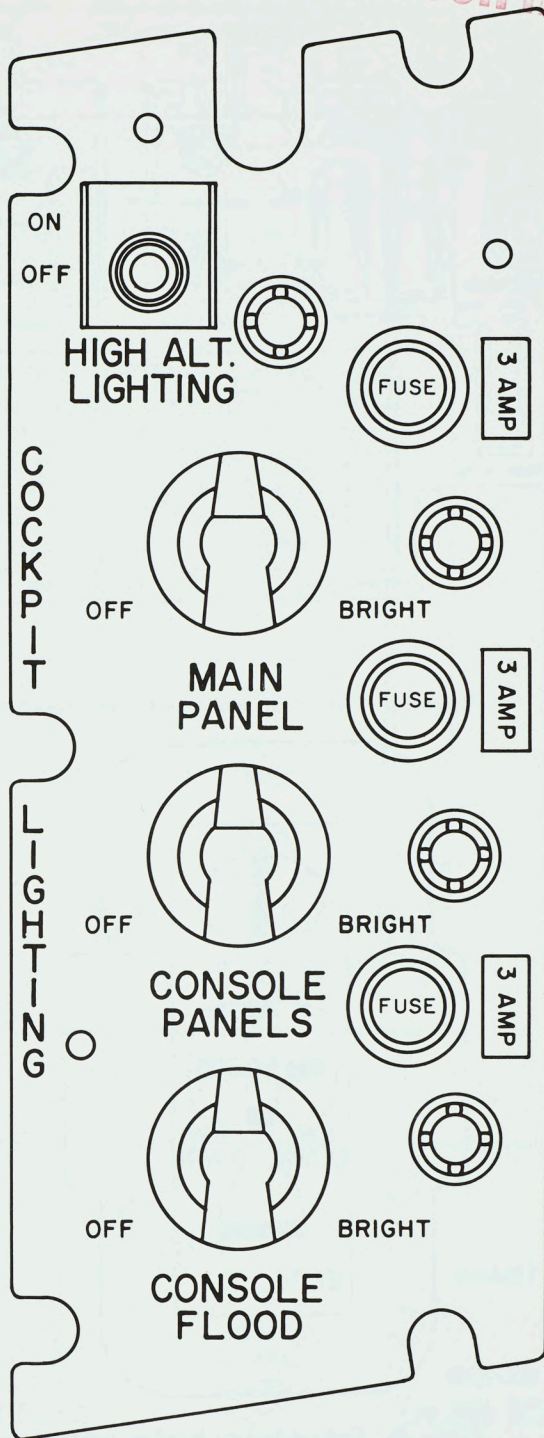

Figure 34. Pilot's Panel and Console-Lights Control Panel

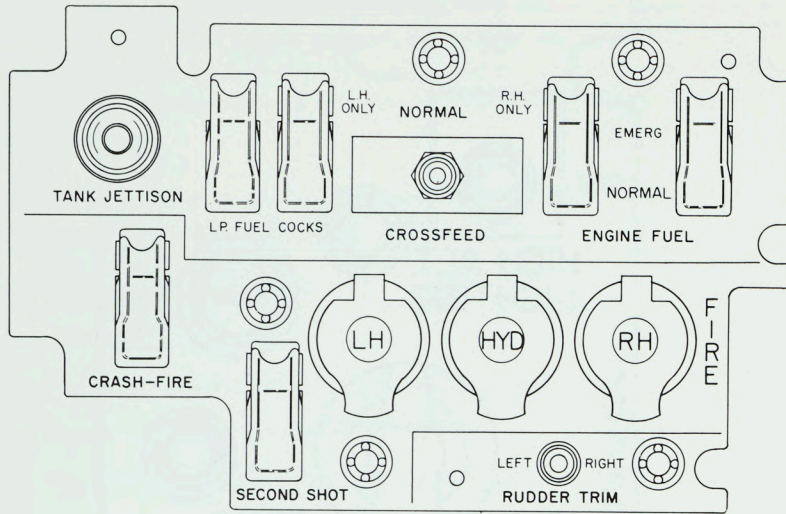

Figure 35. Fire, Fuel, and Trim-Control Panel

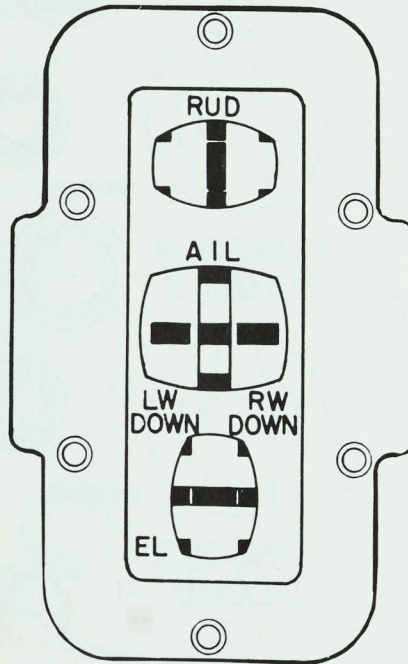

Figure 36. Control-Surface Position Indicator

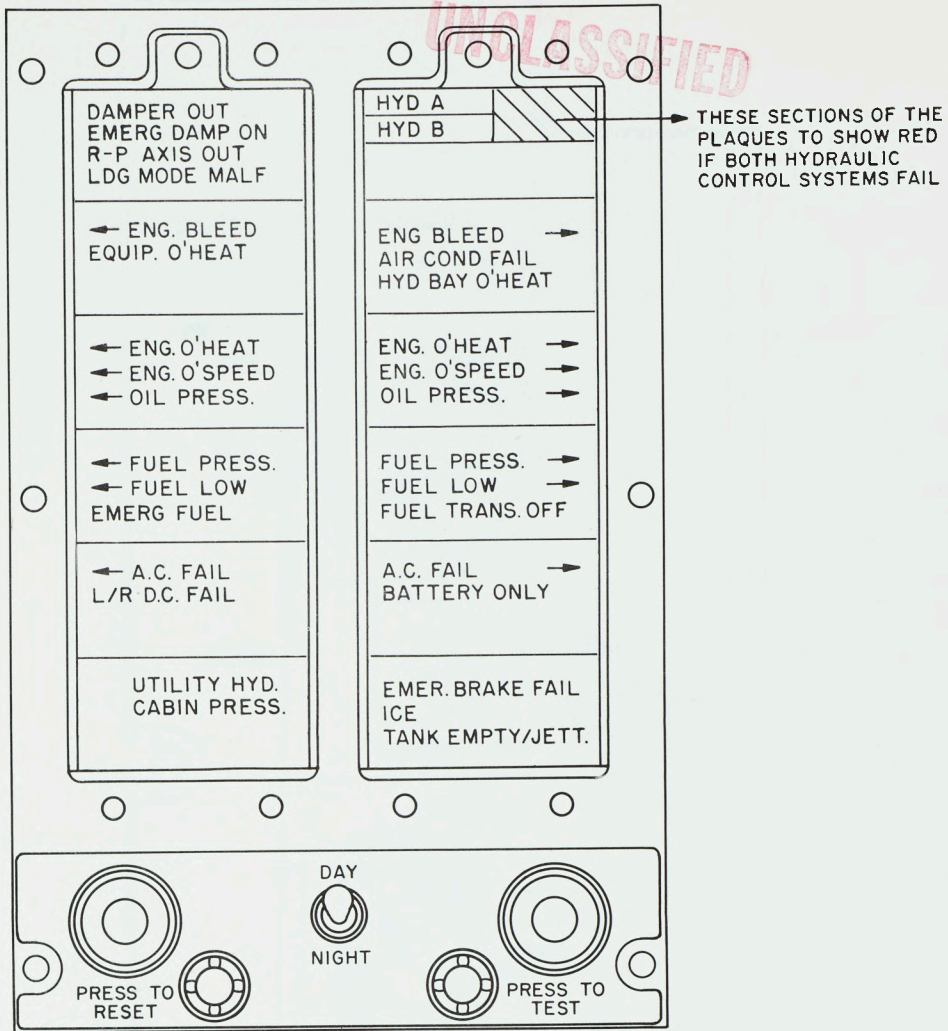

Figure 37. Warning Panel

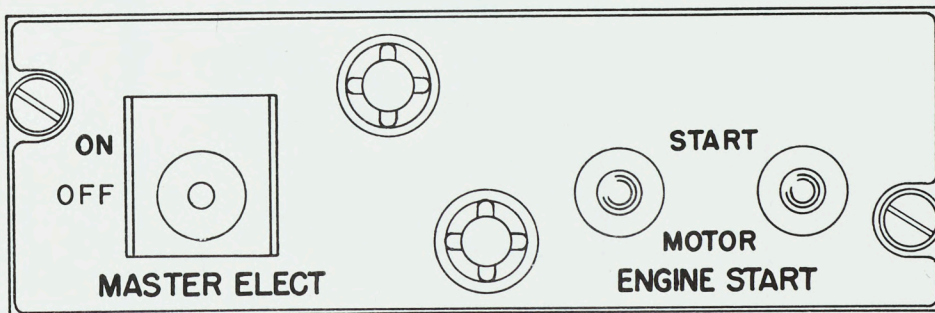

Figure 38. Master Electrical Panel

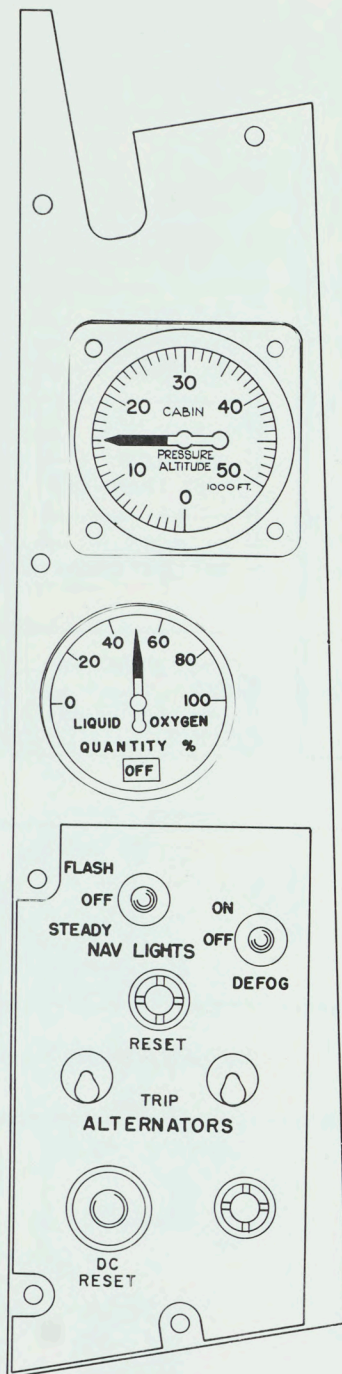

Figure 39. Oxygen Indicator and Miscellaneous Controls

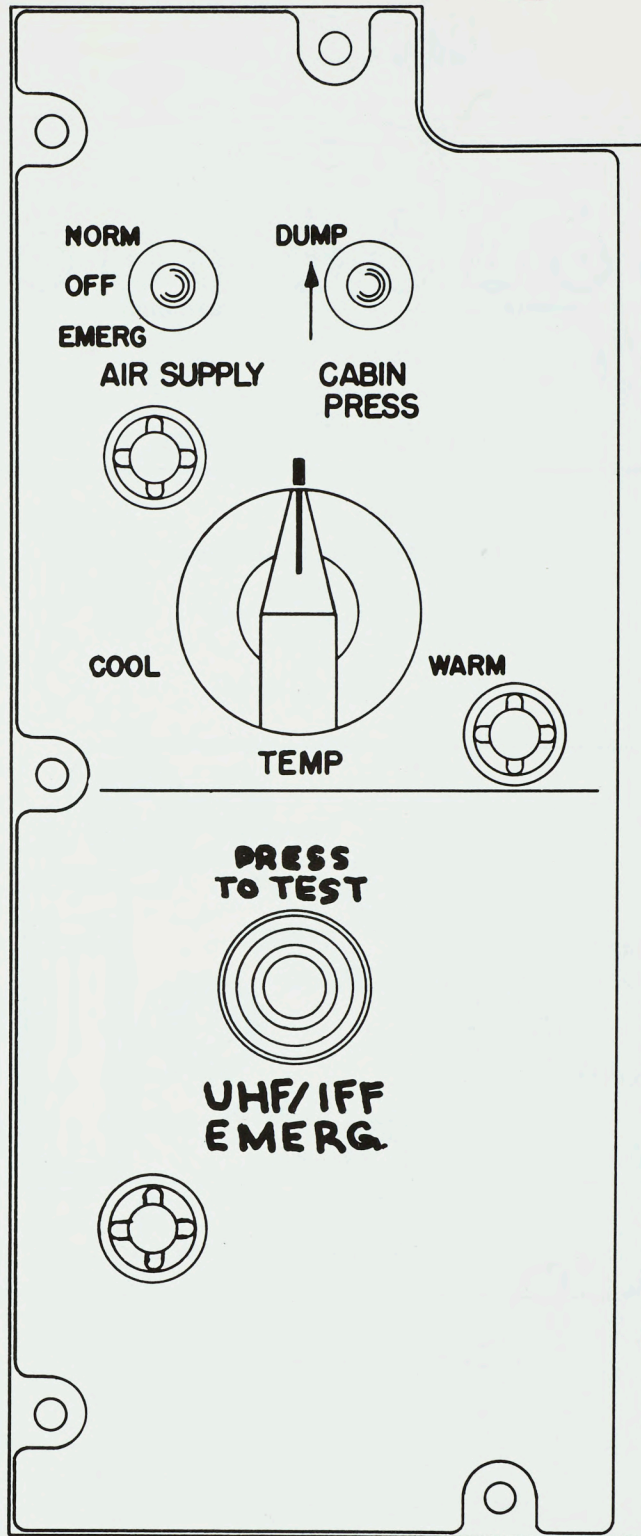

Figure 40. Air Conditioning Panel
SECRET

UNCLASSIFIED

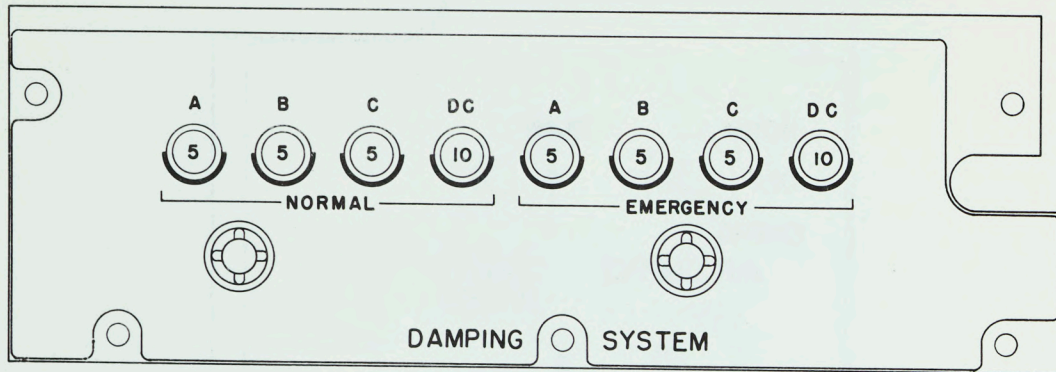

Figure 41. Circuit Breaker Panel

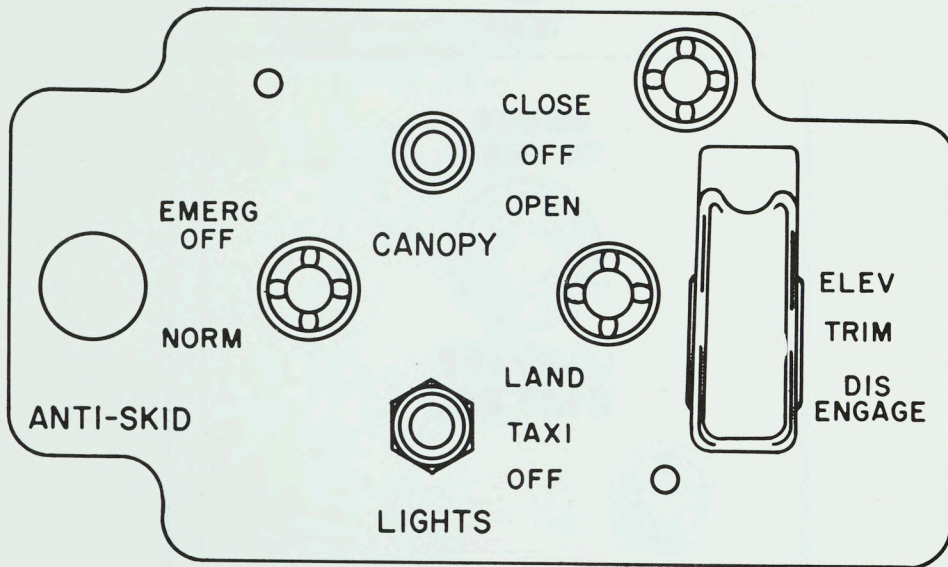

Figure 42. Pilot's Canopy Switch Panel

UNCLASSIFIED

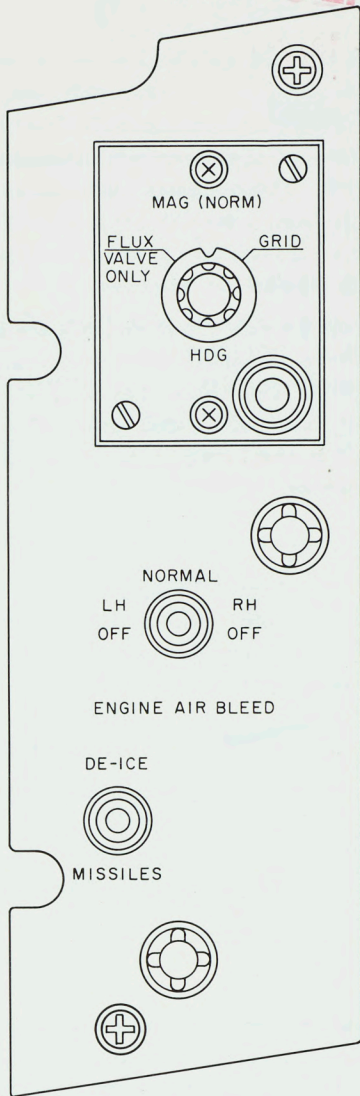

Figure 43. Engine Air-Bleed Panel

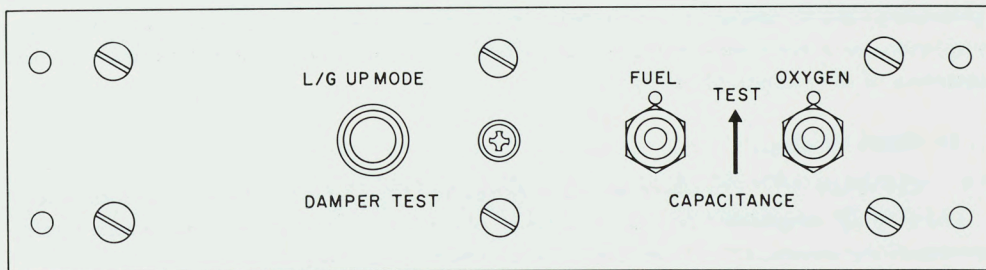

Figure 44. Fuel and Oxygen Test Panel

C. OBSERVER'S PANEL

1. OBS BAIL-OUT COMMAND LIGHT

A red warning light is mounted on the observer's instrument panel for ejection alert. A warning horn also commands bail-out. These signals are actuated simultaneously by the pilot's bail-out command switch.

2. RANGE AND RANGE-RATE METER

The target range and range rate are both shown on the same meter (Figure 45). The range rate is shown by a pointer on the outside concentric circle of the meter, and the range is shown by a pointer on the inside concentric circle. The first half of the scale is calibrated linearly from 0 to 500 yards, and the last half linearly from 500 to 3000 yards. This arrangement allows more accurate reading at the short ranges and at small range rates. The scale indicates yards for the range pointer and knots for the range rate pointer.

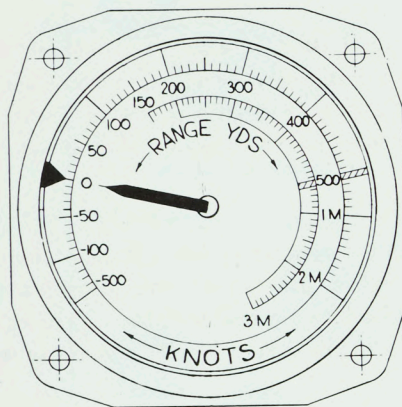

Figure 45. Range and Range-Rate Meter

3. OBSERVER'S RADAR AND IR INDICATOR AND CONTROLS

a. Cathode Ray Tube

The observer's cathode-ray-tube indicator is a 5-1/2-inch square tube with a useable size of 4-1/2 by 4-1/2 inches; it is mounted in the center of the panel. A plexiglas overlay provides lighted scales for range, azimuth, and antenna elevation readings to permit rapid, accurate interpretation of the various displays.

b. Radar Display

The observer's indicator presents information in the form of a B-scan oscilloscopic display. The display components include an antenna elevation strobe, data-link enclosure circle, target-acquisition strobe, and a radar and infrared search presentation.

The display, in data-link mode, is shown in Figure 46. The data-link enclosure circle indicates the most probable target location. The radius of the circle changes to conform to the various operating range scales as selected. During infrared operation, the target appears as a bright range sweep at the correct azimuth.

The elevation of the radar antenna and the IR seeker head will be indicated by the antenna elevation strobe. The target acquisition strobe can be positioned by the hand control. In the normal stowed position of the hand control, the strobe will appear at 0 degrees azimuth and 25 miles range. The strobe is positioned over the target with the hand control, and acquisition is initiated by pressing the acquisition trigger. This signal positions the tracking gate in "live" time and causes it to oscillate over a one-mile range to achieve automatic lock-on. When lock-on is obtained, the target-designator strobe remains positioned over the target, and will follow the target in range. The antenna-elevation strobe and range sweep will continue to indicate the position of the antenna.

c. Sweep-Expand Control

The sweep-expand control allows the observer to select any desired portion of the radar presentation and expand it over a distance of 16 miles. Turning the control selects the desired portion to be expanded, and pulling the knob out expands this portion. The expanded sweep operates only in beacon, ground-map, and 80-mile-search modes of operation.

d. Magnetron Tuning Switch

The tuning switch has two momentary on positions, labeled raise and lower, with a center off position. By holding the switch in either of the momentary positions, the magnetron frequency can be raised or lowered to avoid interference or jamming. Two lights are located on the indicator near the magnetron tuning controls to indicate when the magnetron tuner is operating, and in which direction.

e. Anti-Jam Switch

The anti-jam switch selects a continuously changing radar frequency. When this switch is placed on the on position, the magnetron frequency will be continuously varied in a random manner by the frequency programmer.

f. IFF Interrogate Switch

The IFF pushbutton switch enables the navigator to interrogate airborne targets in the 8,000-yard, and the 16-, 40-, and 80-mile search modes.

g. Receiver Gain Control

The receiver gain control is a ganged potentiometer that varies the IF gain of the radar microwave receiver and the APX-26 receiver, thereby allowing the navigator to reduce or to increase the gain of the receivers and thus to effectively control the contrast of the display.

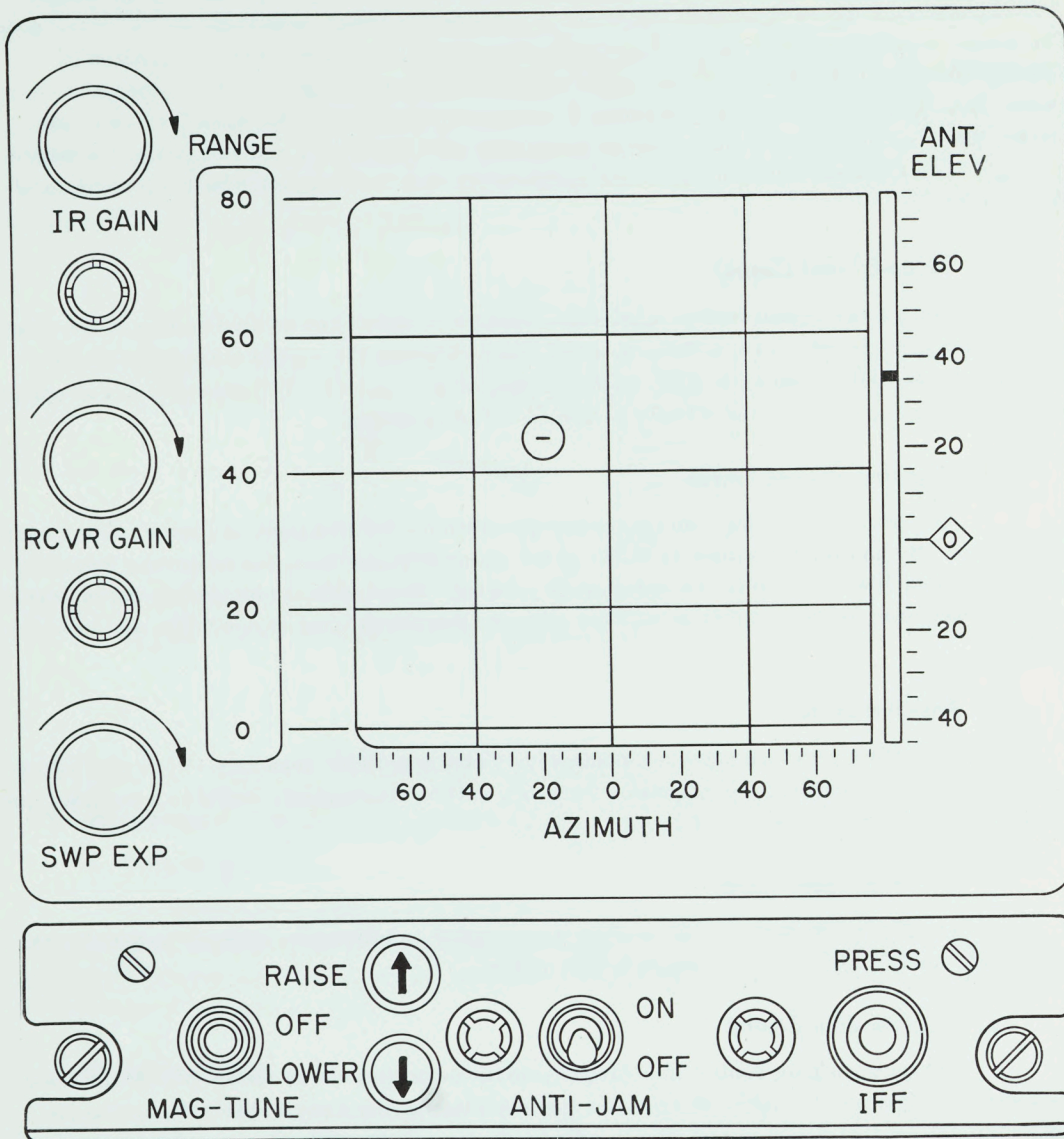

Figure 46. Observer's Radar and IR Indicator and Controls

h. IR Gain Control

The IR gain control is a potentiometer that controls the gain of the infrared receiver, thereby allowing the observer to adjust the intensity for proper display.

i. Range Scales

The range scales are located on a rotating drum to the right of the gain control. They are controlled by the mode selector switch on the Radar IR control panel (see Figure 46).

4. OBSERVER'S RADAR/IR CONTROL PANEL

Figure 47 shows the control panel.

a. Radar Mode Selector

The mode selector switch provides for the following modes of radar operation, with the antenna scan modes selected from the radar auxiliary panel (see Figure 50).

1) AMTI

In the AMTI search position the clutter canceller removes ground clutter from the radar presentation on a 16-mile search range. Sweep expansion, target lock-on, and IFF interrogation are not possible during this mode of operation. The observer, by using the antenna scan selector switch located on the radar auxiliary panel (left console), can select either searchlight mode, manually programmed antenna scan, or automatic antenna scan programmed by data link.

2) 8,000-Yard Search

The 8,000-yard search position permits normal radar operation over an 8,000-yard range with target lock-on and IFF interrogation available. The choices of antenna scan modes are searchlight, observer-programmed, or data-link-programmed.

3) 16-Mile Search

The 16-mile search position permits normal radar operation over a 16-mile range and allows activation of both target lock-on and the IFF interrogation switch. The choices of antenna operation are the same as those offered in the 8,000-yard search position.

4) 40-Mile Search

The 40-mile search mode permits normal radar operation over a 40-mile range with target lock-on and IFF interrogation available. The choices of antenna operation are the same as those offered in the 8,000-yard search range.

5) 80-Mile Search

The 80-mile search mode permits normal radar operation over an 80-mile range without the lock-on feature. Radar presentation expansion using the Expand Control and IFF interrogation are available in this mode. The choices of antenna scan operation are the same as those in the 8,000-yard search position.

UNCLASSIFIED

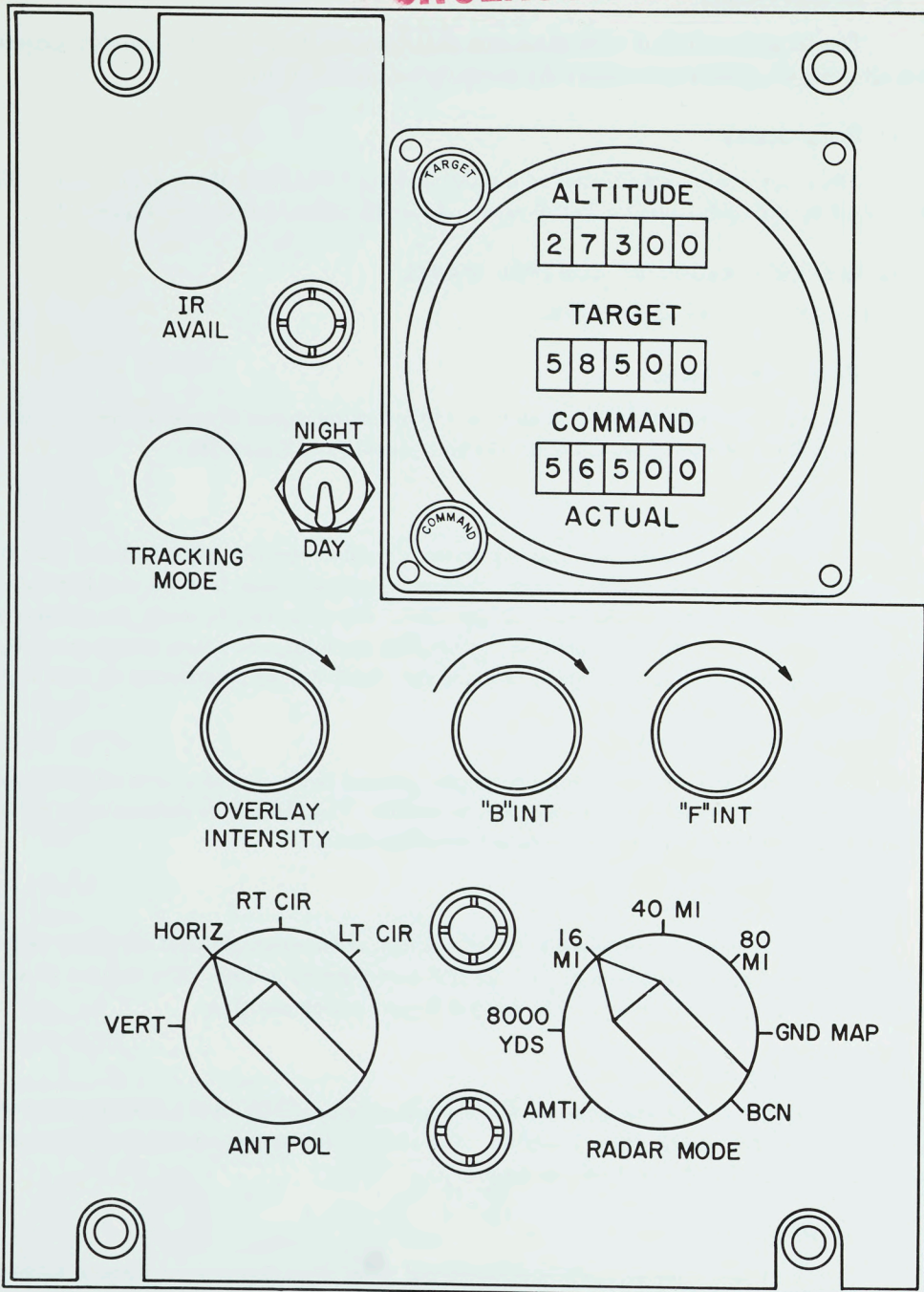

Figure 47. Observer's Radar/IR Controls

UNCLASSIFIED

6) 200-Mile Ground Map

The 200-mile ground map mode permits reconnaissance radar operation over a 200-mile range; neither the lock-on feature nor IFF interrogation is available. A choice of either searchlight mode, programmed one-bar scan pattern controlled by the observer, or ground control through data link is available. Sweep expansion is available.

7) 200-Mile Beacon

The 200-mile beacon mode permits reconnaissance for radar beacon stations within a 200-mile range. Target lock-on and IFF interrogation are not possible in this mode. A choice of either searchlight mode or programmed one-bar antenna scan pattern controlled by the observer, or ground control through data link is available. Sweep expansion is available.

b. Antenna Polarization Selector

The antenna polarization selector permits selection of one of the following types of radar polarization to either minimize jamming or enhance detection range:

- (1) Vertical,
- (2) Horizontal,
- (3) Right Circular, and
- (4) Left Circular.

c. B-Display Intensity Control

The B-display intensity control permits the observer to adjust the brightness of IR and radar video to suit the ambient light conditions.

d. F-Display Intensity Control

The F-display intensity control permits the observer to adjust the brightness of his target designator and target elevation display.

e. IR Night-Doy Switch

The night-day switch decreases the sensitivity of the IR seeker during daytime operation where a high ambient IR level is present and increases the sensitivity to a maximum for optimum performance during night operation.

f. Overlay Intensity Control

The overlay control permits the observer to adjust, as desired, the brightness of the grid overlay.

g. Tracking Mode Indicator

The tracking mode indicator light shows whether IR-seeker or radar tracking is being used.

UNCLASSIFIED

h. IR Availability Indicator

Lighting of the IR availability lamp indicates that a target is within the field of view of the IR seeker and is of sufficient amplitude to permit IR angle tracking.

5. ALTITUDE DATA COUNTERS

The altitude data counters (Figure 48) display target altitude, command altitude, and aircraft altitude on five-digit, servo-positioned counters.

The command altitude and target altitude may be automatically inserted data-link information or be manually inserted by means of the C and T-slewing switches, depending on the position of the target-data switch on the target-data display panel (pictured later). In the data-link position of this switch, the altitudes displayed are provided by data link. Otherwise, command and target altitudes are received by voice communications and are inserted or corrected manually. Two slewing switches at the corners of the indicator are provided on the instrument for this purpose.

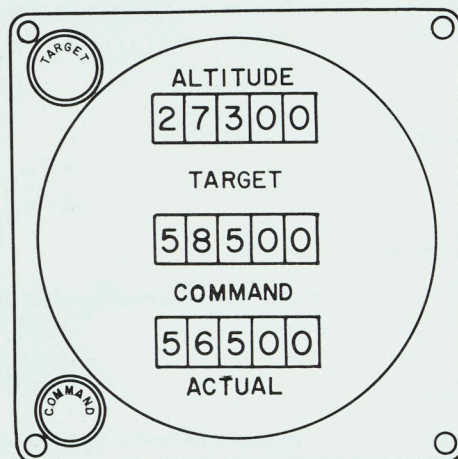

Figure 48. Altitude Data Counters

The aircraft-altitude servo receives its input from the air-data computer at all times.

D. OBSERVER'S CONSOLES

1. IN-FLIGHT TEST PANEL

a. Function and Description

The test panel (Figure 49) allows the observer to make an in-flight check of the operation of the IR seeker without an actual target; it also contains warning lights to indicate the failure or marginal operation of other sections of the radar system. The panel contains the following controls and warning lights.

UNCLASSIFIED

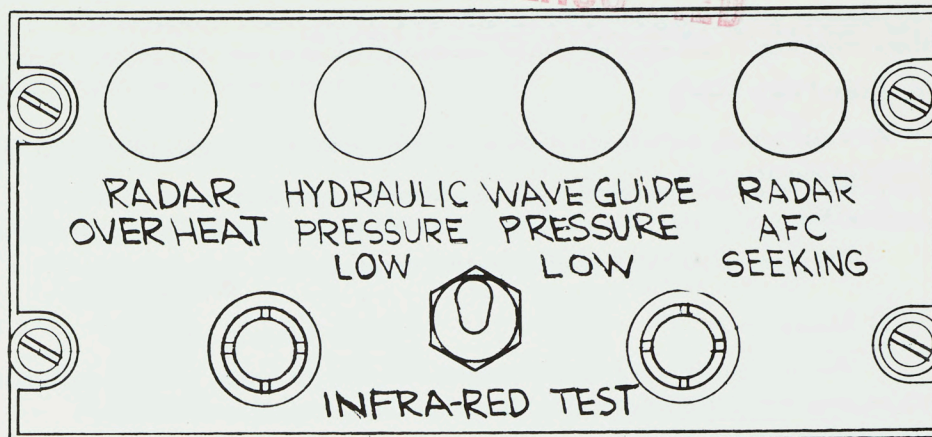

Figure 49. In-Flight Test Panel

b. IR Test

An IR test switch allows the observer to make a qualitative check of the IR seeker circuitry and display presentation. The switch turns on a small incandescent lamp within the IR seeker dome, and the lamp acts as a pseudo IR target, appearing on the display at zero degrees azimuth. The IR seeker can also be made to lock onto the pseudo target.

c. Radar AFC Seeking

A warning light indicates that the radar AFC is not locked to the magnetron frequency. Under this condition the radar is inoperative.

d. Waveguide Pressure

A low-waveguide-pressure warning lamp is lighted when the air pressure within the radar waveguide has fallen below a safe level and actuates the protective interlock. Continued operation is then possible by placing the master power switch in the emergency position, but this procedure risks damage to the magnetron.

e. Hydraulic Pressure

A low-hydraulic-pressure warning lamp is lighted when the antenna-drive hydraulic pressure is below the normal operating pressure.

f. Modulator Overheat

A modulator-overheat warning lamp is lighted when the temperature of the nose-section cooling air has risen above the safe operating level, actuating the protective interlock. Continued operation, accomplished by placing the master power switch in the emergency position, risks exceeding the component ambient temperature ratings.

2. RADAR AUXILIARY CONTROL PANEL

The radar auxiliary control panel is pictured in Figure 50.

a. Radar Power Switch

A master switch controls the power to the fire-control subsystem. This switch has the following positions:

1) Off

All power to the fire-control subsystem is removed.

2) Standby

Filament power to the system energizes the missile heating blankets and starts the radar gyro heaters, waveguide air pump, and magnetron liquid-cooling system pump.

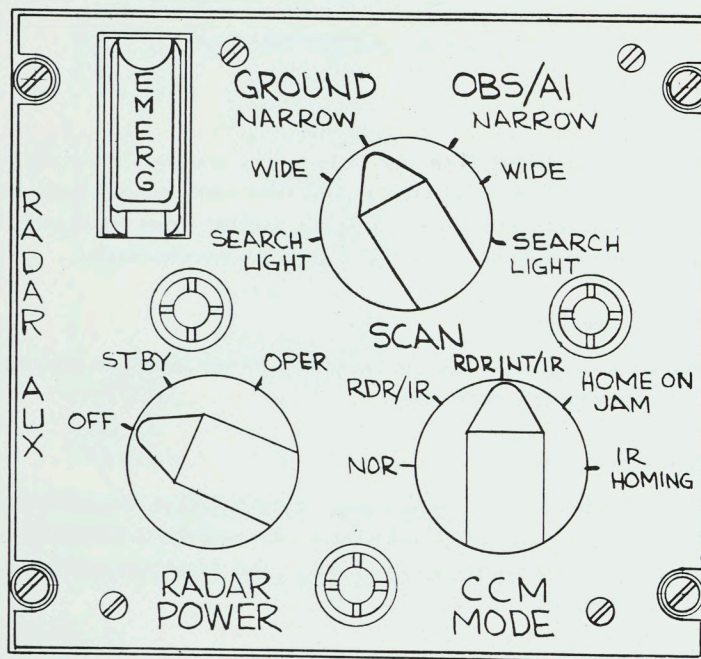

Figure 50. Radar Auxiliary Control Panel

3) Operate

Voltage is applied to the system and the radar begins operation. The inadvertent application of high voltage to the radar transmitter prior to warmup is prevented by a fixed time delay. The radar high-voltage protective devices are reset if the switch is returned to standby, then turned back to operate. Missile power is applied when the aircraft is airborne.

b. Emergency Power Switch

The emergency power switch allows normal radar operation before the time delay relays have closed and/or after the protective interlocks have been actuated. A protective guard, which is usually wired down, covers the switch.

c. CCM Mode Selector

A CCM selector provides alternate methods of target location to be used in the event of radar jamming. The following counter-countermeasures are available as switch positions.

1) Normal

The radar operates normally.

2) Rodor/IR

The azimuth and elevation of the target are determined by the IR seeker and the range by the radar. The computer operates normally to compute a lead-collision or lead-pursuit course.

3) Rodor Intermittent/IR

The radar-intermittent/IR mode is identical to the preceding mode except that the radar, which determines the target range, does not operate conventionally. Transmission from the antenna is programmed in short bursts between periods of radar silence, during which the transmitter operates into a dummy load. Range memory is maintained between the programmed bursts to accomplish tracking.

4) Home on Jam

The home-on-jam mode is used to close the range for either an optical or a normal attack. The radar homes in azimuth and elevation on radar radiation from the target. The range gate is fixed at about 20 miles.

5) IR Homing

The IR-homing mode is used to close the range for either an optical or normal attack. The IR seeker tracks the target in azimuth and elevation.

d. Antenna Scan Selector

The antenna scan selector switch allows the choice of wide or narrow programmed scans, or searchlight operation, which may be controlled either by GCI or by the observer. This switch has the following positions.

1) Searchlight (Ground Control)

The searchlight (ground control) scan mode allows the antenna to be positioned in azimuth by the lateral movement of the hand control. Antenna elevation is automatically set by data link but can be trimmed by the use of the elevation thumb wheel.

2) Wide (Ground Control)

The wide (ground control) scan pattern is a 140-degree programmed scan pattern. For all search ranges a three-bar scan is programmed in elevation. A one-bar scan is used in the 200-mile ground map and beacon ranges. Gross antenna elevation is set by the ground control through data link, with fine adjustments being made by the operator.

3) Narrow (Ground Control)

The narrow (ground control) scan pattern is 40-degrees in width, the center of which is determined by ground control through the data link. On all search ranges the antenna is programmed in elevation for a three-bar scan; on the 200-mile ground map and beacon ranges a one-bar scan is used. Gross antenna elevation is determined by ground control through the data link; fine adjustments can be made by the use of the hand-control thumb wheel.

4) Narrow (Local Control)

The narrow (local control) scan pattern sets the antenna in a 40-degree programmed scan pattern, the center of which is determined by the lateral position of the hand control. On all search ranges, the antenna is programmed in elevation for a three-bar scan; on the 200-mile ground map and beacon ranges a one-bar scan is used. Antenna elevation is controlled by the hand-control thumb wheel.

5) Wide (Local Control)

The wide (local control) scan is a 140-degree scan pattern programmed in elevation for a three-bar scan. On the 200-mile ground map and beacon ranges a one-bar scan is used. Antenna elevation is controlled by the hand-control elevation thumb wheel.

6) Searchlight (Local Control)

The observer positions the antenna in azimuth by lateral movement of the hand control and in elevation by the antenna elevation thumb wheel.

3. ARD-501 (ECM HOMER) CONTROL PANEL

The ARD-501 equipment is still in the feasibility study stage and specific information is unavailable at this time. The ECM homer will provide a very sensitive direction finder enabling the interceptor to home on an airborne source of electromagnetic radiation in the L and S frequency bands. Extremely high directional sensitivity will be achieved by a combination of antenna beam switching and radiometer techniques.

4. ARC-552 (UHF) CONTROL PANEL

a. Function and Description

The ARC-552 control box (Figure 51) operates the transmitter-receiver RT-332 when the observer has functional control. Four dials and associated rotary switches are employed for manual selection of the desired operating frequency. The preset-manual control must be in the manual position to enable setting of these dials. The dial indications are read from left to right, i.e., a reading of 3-4-7-9 represents a frequency setting of 347.9 mc.

UNCLASSIFIED

b. Function Selector Switch

A four-position rotary switch for controlling primary input power to the equipment and for selecting the mode of transmission has the following positions:

1) OFF

In the off position all power to the radio set is off.

2) T/R (Transmit and Receive)

In the T/R position the main receiver will receive until the system push-to-talk button is depressed causing the transmitter to go "on the air."

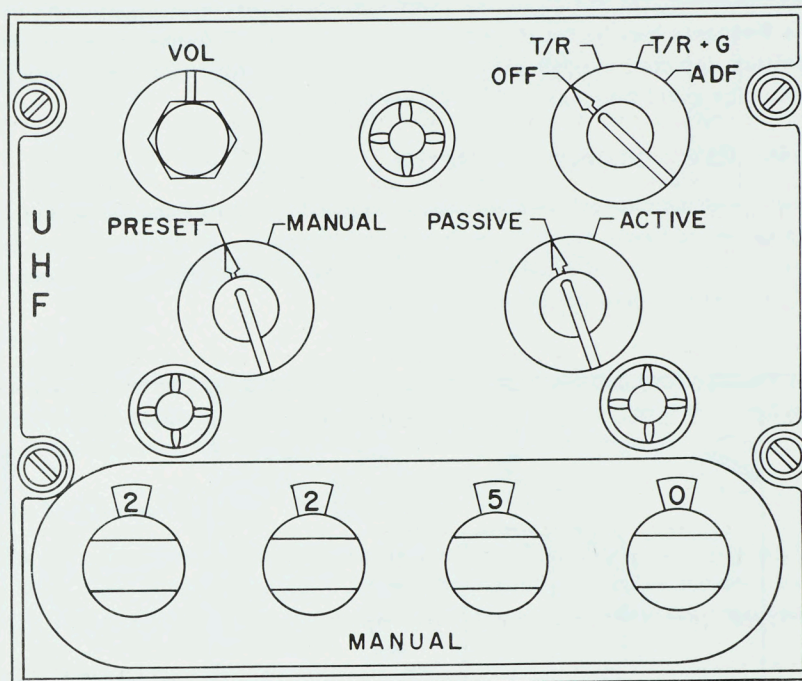

Figure 51. ARC-552 Control Panel (OBS/AI)

3) T/R + G

In the T/R + G position the main and guard receivers and the transmitter are operative.

4) ADF

In the ADF position the connections between the ARC-552 and the ARA-25 are actuated for automatic direction-finding purposes; the transmitter is disabled.

UNCLASSIFIED

c. Volume Control

A rotary volume control marked vol, which ordinarily adjusts the amplitude of the audio signals delivered to the intercommunication set AN/AIC-10A is disconnected and therefore inactive.

d. Active-Passive Switch

The active-passive switch, in the active position, transfers control of the ARC-552 transceiver to the crew member initiating the action.

e. Preset-Manual Switch

The preset-manual switch, in the manual position, places the tuning circuitry in a condition where a frequency may be set in manually using the manual frequency setting switches. In the preset position, the crew member can use the channel selector switch which provides 18 preset channels plus guard frequency. (See Figure 52.)

5. ARC-552 (UHF) CHANNEL SELECTOR

The setting of the channel selector switch Figure 52, controls the channel or frequency to which the transmitter and main receiver are tuned. Additionally, the equipment may be tuned to the guard frequency. Numbers 1-23 denote the channel to which the equipment has been set; and position "G" is used for guard frequency operation.

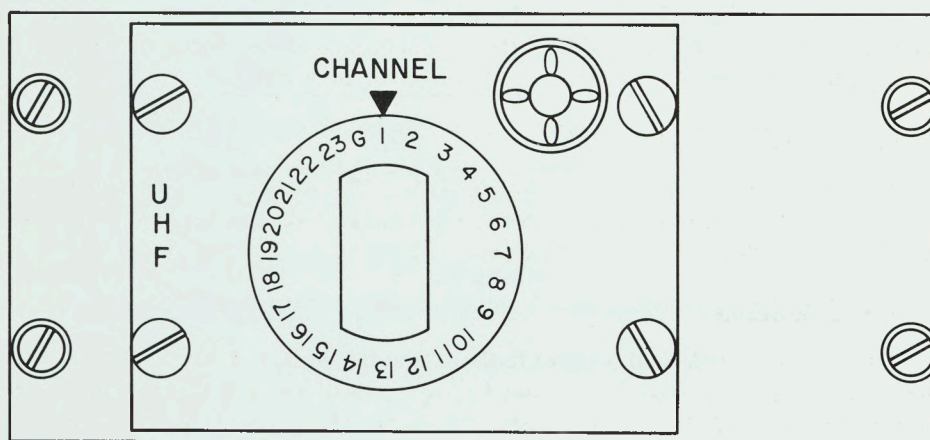

Figure 52. ARC-552 (UHF) Channel Selector

6. ARR-48 (DATA LINK) CONTROL PANEL

a. Function and Description

The control panel shown in Figure 53 provides all controls for frequency selection and modes of operation. The converter controls are located in the upper portion of the panel; the receiver controls in the lower portion. A log plate for recording pre-set channels is also provided.

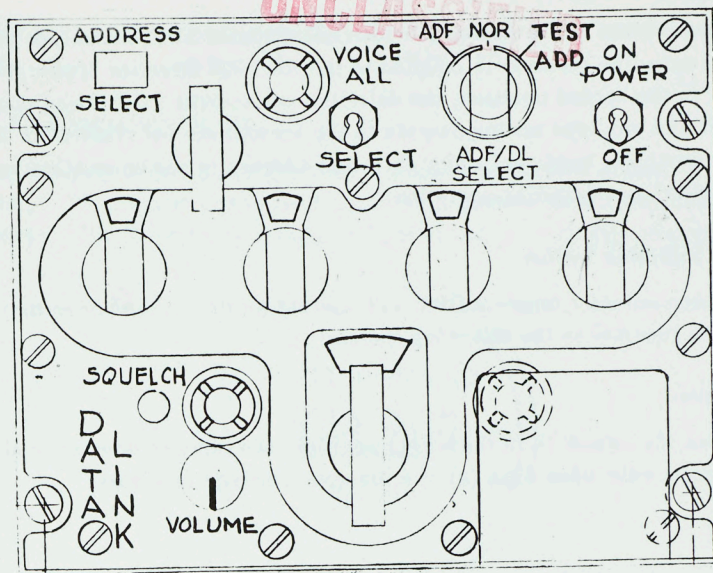

Figure 53. ARR-48 Data-Link Control

b. Power Switch

Primary power for both receiver and converter is controlled by the toggle switch located in the upper right-hand corner. This switch, when in the on position, provides 28 d-c volts for the power relays in the receiver, the converter, and the coupler power supply.

c. Pre-Set Channel Selector

The receiver selector switch (lower center) is a 27-position knob mechanically coupled to a memory drum. The drum is capable of storing the digital information required for 26 pre-set channels. The 27th position is used to switch over to the manual selection switches.

d. Manual Switching

After setting the channel selector to the M-position, manual channel selection is accomplished by means of four setting knobs, one for each digit of the 1750 channels present in the spectrum from 225.0 mc to 399.9 mc. Associated with each setting knob is a counter readout.

e. Address Selector Switch

The 32-position address selector switch (top left) is a five-digit binary sequence selector. The five banks of the switch are such that address number 1 corresponds to the binary sequence 00001. A counter, coupled to the switches by gearing, provides the means of address indication.

f. Volume and Squelch

A potentiometer provides control of data-link voice volume. A squelch switch is also provided to cut squelch in or out.

g. ADF/DL Selector

A three-position rotary switch provides selection of ADF, normal, or test address selection. In ADF the data-link receiver is coupled to the ARA-25 direction finder group to provide ADF capability. In the normal position, the data-link set accepts information addressed to that particular aircraft and provides analog outputs to the appropriate subsystem. In test address the address selector switch is bypassed and a universal address is set up to allow reception of a test message to check out data-link operation.

h. Voice Selection Switch

The voice selector toggle switch will operate a relay in the converter to channel the audio output of the receiver in the following manner:

1) Select

When the switch is in the select position, the relay is de-energized and will transfer audio to the intercom only when digit (x) of a discrete message is a mark.

2) All

In the all position, the relay is energized and the audio is available to the intercom at all times.

7. ANTENNA-DUPLEXER CONTROL PANEL

a. Function and Description

The antenna duplexer (Figure 54) controls the selection of UHF antennas and the antenna for the IFF equipment.

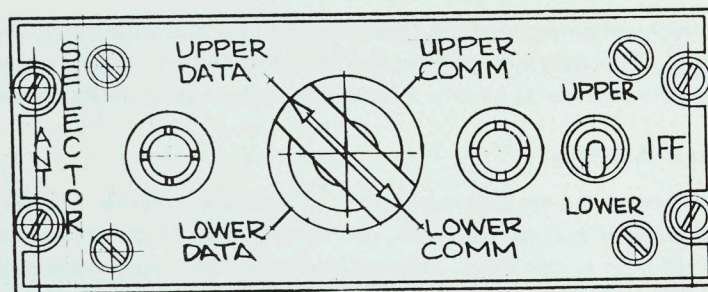

Figure 54. Antenna-Duplexer Control Panel

b. UHF Antenna-Position Selector

The left switch on the panel controls the UHF antenna selection. In one position, the ARC-552 is connected to the upper (tail cap) antenna and the ARR-48 is connected to the lower (belly) antenna. In the other position, the opposite connections are made.

c. APX-25 Antenna Selector

The right switch controls selection of either the upper or lower antenna for the APX-25 IFF equipment.

8. TRUE-AIRSPEED COUNTER

The true-airspeed indicator (Figure 55) is a servo-positioned counter with input from the air-data computer. The display consists of a four-digit counter which provides readability to the nearest five knots. The indicator is integrally lighted and hermetically sealed.

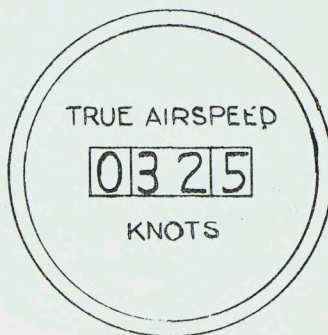

Figure 55. True-Airspeed Indicator

9. TOTAL-FUEL INDICATOR

Space is being reserved on the right-hand console for an instrument to show total fuel. The instrument comprises an indicator and an intermediate totalizing fuel-gage system. The inputs to this device are obtained from the fuel-gage indicators on the pilot's panel. The instrument displays to the observer the remaining total fuel quantity in pounds.

10. WIND-DATA DISPLAY

a. Function and Description

The wind-data display (Figure 56) provides means for reading wind speed and direction, and controls for setting in the wind information and grivation into the computer. Slewing switches are provided for aligning the platform when normal facilities are not available.

b. Wind-Speed Counter

The wind-speed counter displays the value of wind velocity stored in the computer at any time. The control marked R allows manual insertion of wind speed in the computer.

c. Wind Direction Indicator

A moving bug indicates the wind direction relative to grid North. The control marked θ allows manual insertion of a value for wind direction in the computer. If the Doppler radar is tracking, it also controls the setting of wind direction and will override a manual setting. A light indicates when the Doppler radar is not tracking.

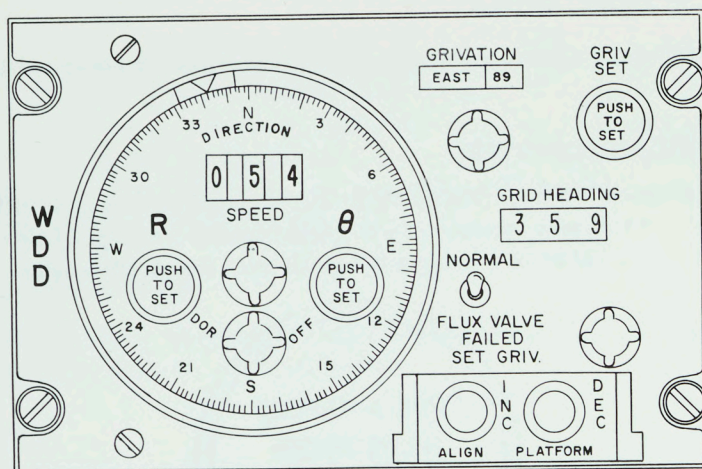

Figure 56. Wind-Data Display

d. Grivotion Indicator

The grivation indicator displays the value of grivation at the aircraft's present position. Normally, the displayed value is the difference between the grid heading and magnetic heading derived from the vertical and heading reference and the magnetic compass. Grivation may be inserted manually by means of the grivation-set knob.

e. Align Platform

The platform may be aligned manually when the aircraft is on the ground by using the Inc and Dec buttons which are under a protective cover. A grid heading counter shows the resultant alignment motion.

11. TARGET DATA DISPLAY

a. Function and Description

The target-data display panel (Figure 57) displays information concerning the target, the source of the target information, and the base destination for the aircraft.

b. GCI Selector

The GCI pushbuttons are interlocked with each other and with those of base selector at the bottom of the panel so that only one or the other can be operative at any time. Four buttons provide for insertion into the computer of the preset coordinates and convergency value of the GCI station controlling the aircraft. One button inserts the coordinates of the origin of the grid.

c. Target Bearing-Distance Indicator

The upper of the two circular dials displays the distance and bearing of the target from the GCI station. A bug moves around a compass card to indicate the bearing; the counter indicates

UNCLASSIFIED

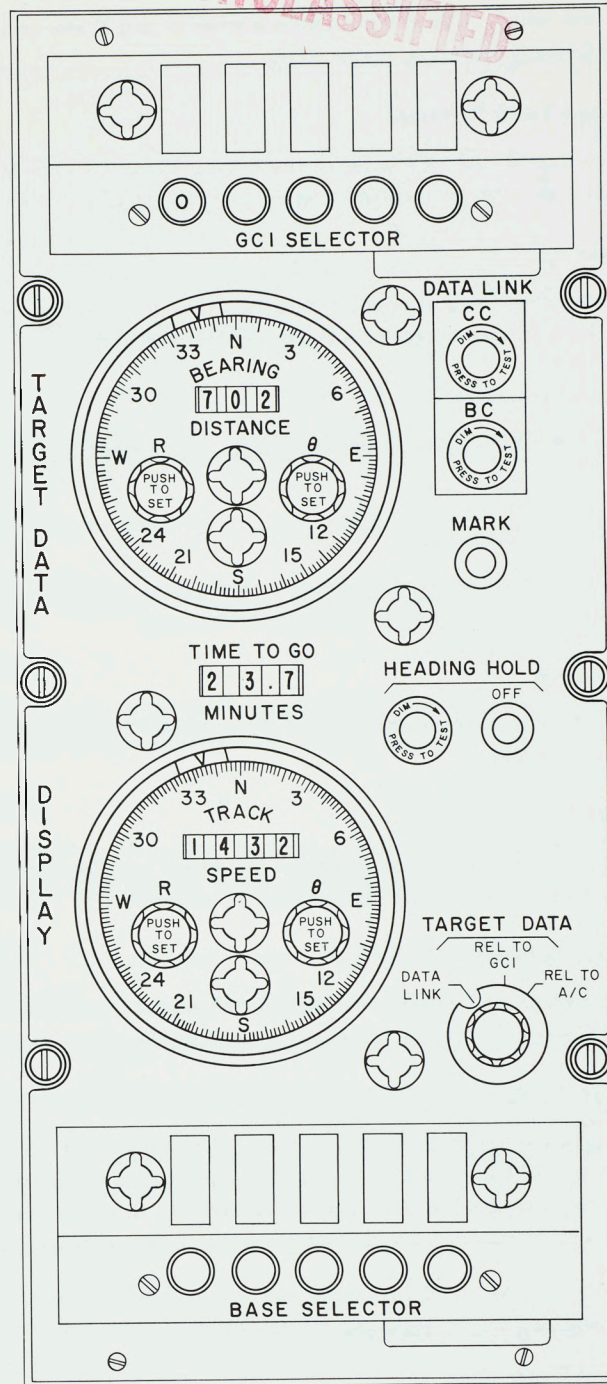

Figure 57. Target-Data Display

the distance in nautical miles. The control knobs marked θ and R are used to insert manually the target bearing and the target distance, respectively.

d. Target Speed-Track Indicator

The lower circular dial is similar to the bearing-distance indicator in operation. Target speed and target track may also be inserted manually by means of the R and θ knobs, respectively.

e. Time-Ta-Go

The time-to-go mechanical counter indicates time-to-go in minutes and tenths of minutes. The destination may be a moving target or a fixed point on the earth.

f. Close-Control Indicator

The close-control indicator lamp, upper right, is on when the close control mode of data link is available.

g. Broadcast-Control Indicator

As above, the broadcast-control indicator lamp is on when the broadcast control mode of data link is available. Both lights are of the push-to-test type.

h. Mark Pushbutton

The mark button is depressed to signal the computer the time at which manually inserted target information becomes true.

i. Target-Data Switch

The target data switch is used to select the datum position for the target data and to select either automatic insertion by data link or manual insertion.

j. Heading-Hold Indicator

The heading-hold lamp automatically lights whenever information is being inserted into the computer. The heading hold may be released by pushing the button marked off.

k. Base-Station Selector

The base selector pushbuttons are mechanically interlocked with each other and electrically interlocked with the GCI pushbuttons to prevent selection of two pushbuttons simultaneously. A base pushbutton is depressed when it is desired to navigate to a pre-selected base. Depressing a base pushbutton results in entering the grid coordinates of the selected base into the navigation computer.

12. NAVIGATION-COMPUTER CONTROL PANEL

o. Function and Description

The navigation computer panel (Figure 58) contains switches that control power to the computer, the input selector switch for the observer's destination indicator, and the Doppler-radar power switch.

UNCLASSIFIED

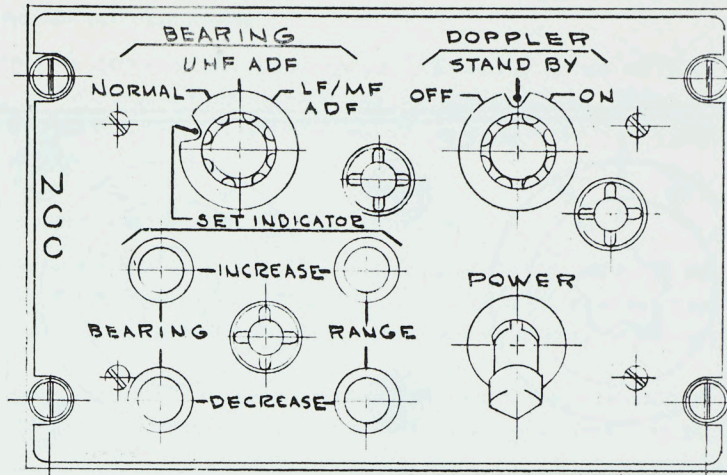

Figure 58. Navigation-Computer Control Panel

b. Power Switch

The power switch controls the application of power to the navigation computer, with the exception of the power to the observer's destination indicator and the grivation circuits.

c. Bearing Switch

The bearing switch allows the observer to select heading information for presentation on the bearing pointer and command bug of the destination indicator. The four positions of this switch are:

1. *UHF ADF* -- This position selects the ARA-25 information for display,
2. *LF/MF ADF* -- This position selects the ARN-6 radio compass output,
3. *Normal* -- In this position the navigation computer output is displayed, and
4. *Set-Indicator* -- This position allows insertion of position fix into the computer. It enables the four slewing buttons at the bottom of the panel to be used to set up values for range and bearing from a ground station on the display for insertion into the computer.

d. Doppler Switch

The Doppler-radar control switch has three positions: off, standby, and on. In the standby position the Doppler radar is turned on but its output is not connected into the navigation computer.

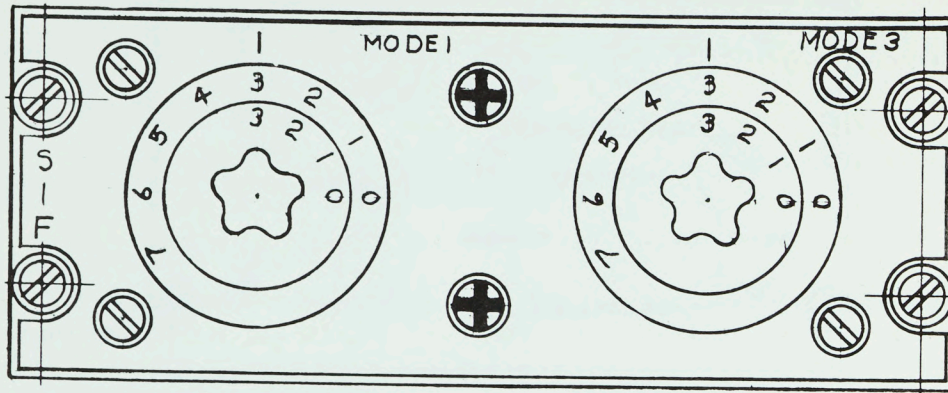

Figure 59. APX-25A Coder Control Panel

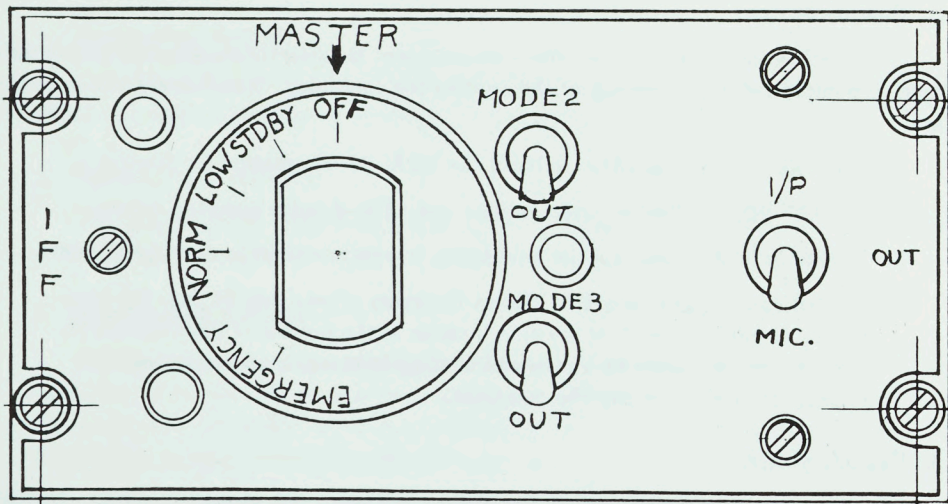

Figure 60. APX-25A Transponder Control Panel

UNCLASSIFIED

13. APX-25A (IFF) CONTROL PANELS

a. Function and Description

The APX-25A provides the air-ground IFF facility for the ASTRA I system. The equipment includes an R/T unit, a coder-decoder and two control boxes. These control panels are the transponder set control C-1158 (Figure 59) and the coder control C-1128 (Figure 60) identified IFF and SIF respectively.

b. Transponder Set Control (C-1158/APX-25A)

Mode selections are provided by control panel C-1158/APX-25 through toggle switch settings located on the front panel. In addition, this control includes the master switch for selecting the type of operation. Off, standby, low, normal and emergency switch positions are provided.

The SIF (security identification feature) of the coder control panel contains two sets of coaxial dials for setting up the code-of-the-day for modes 1 and 3 respectively. In both cases the outer knot sets up the first digit and the inner concentric knob sets up the second digit of the code number.

14. APX-26/27 (IFF) CONTROL PANEL

a. Function and Description

The APX-26/27 control panel, Figure 61, controls the operation of the APX-26, APX-27 air-to-air IFF equipment.

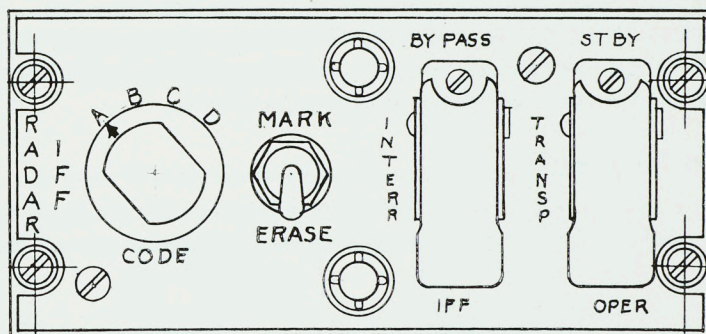

Figure 61. APX-26/27 Control Panel

b. Code Selector Switch

This four-position switch selects the code-of-the-day; (A, B, C, or D) on both the APX-26 and APX-27 equipments. Each position corresponds to a given code with which the IFF equipment will interrogate.

c. Mark-Erase Switch

The mark-erase switch allows the navigator to identify aircraft equipped with the APX-26/27. In the mark position, returns from aircraft equipped with APX-27 have increased

intensity on the radar display while the returns of aircraft not replying remain unchanged. The returns of planes equipped with APX-27 are blanked out in the erase position, while the replies of planes not equipped with APX-27 remain unchanged.

d. By-Pass Switch

The by-pass switch can be used to bypass the APX-26 electrical synchronizer in the event of malfunctioning, thus permitting the fire-control radar to continue functioning.

e. Standby-Operate Switch

In operate, the standby-operate switch energizes both the transmitter and the receiver, in the standby position it energizes only the receiver.

15. ADDITIONAL PANELS

Console panels pictured, but not discussed here are: Figure 62, observer's panel and console lights control; Figure 63, observer's canopy control.

E. OBSERVER'S HAND CONTROL

1. OBSERVER'S HAND CONTROL PANEL

The hand control is shown in Figure 64.

a. Function and Description

The hand control allows the observer to position the scan center of the antenna when in OBS/AI control. The target acquisition strobe is always positioned by the hand control. Movement of the control grip fore and aft moves the local target designator in range, and movement left and right positions the target designator or antenna in azimuth.

b. Nose-Tail Control

The nose-tail switch allows the observer to select the true target from mechanical radar jamming such as chaff. This switch is located on the hand control grip and has the following two positions.

1) Nose

The nose position permits lock-on to the leading edge of the returned radar pulse in the event of enemy ECM.

2) Tail

The tail position permits lock-on to the trailing edge of the returned radar pulse in the event of enemy ECM.

3) Pregate

The pregate position permits use of predated video for range tracking.

UNCLASSIFIED

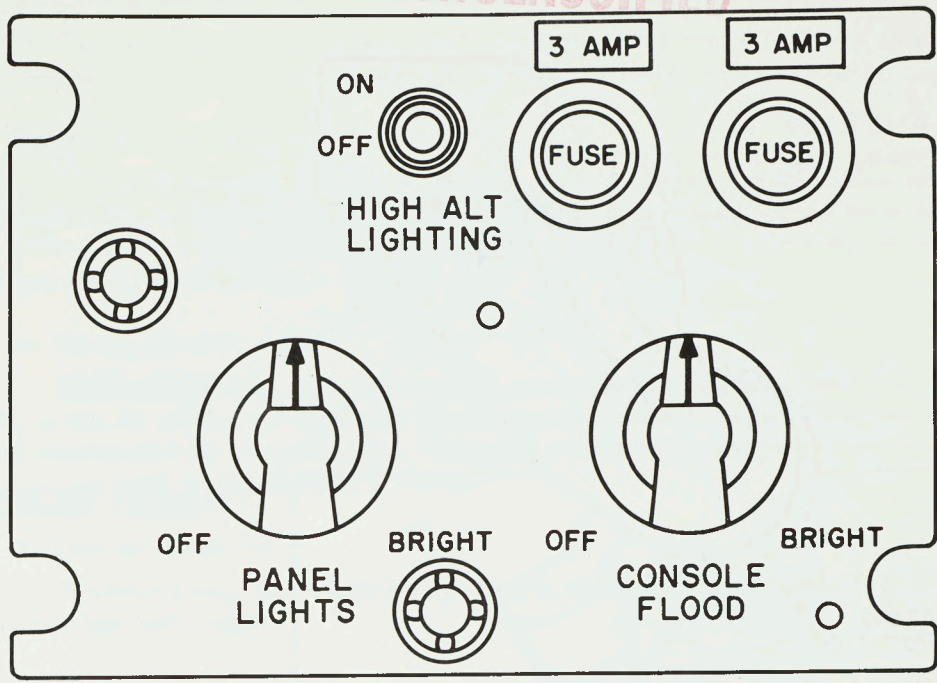

Figure 62. Observer's Panel and Console Lights Control

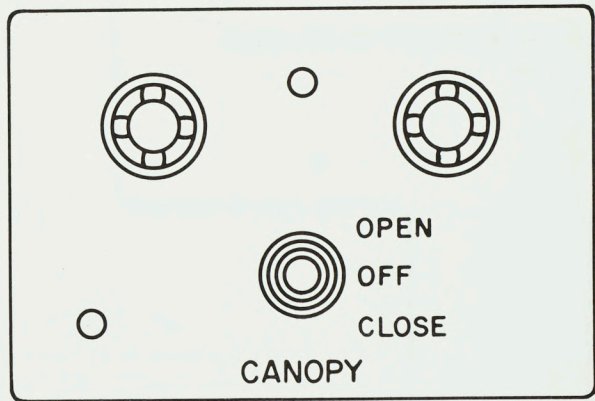

Figure 63. Observer's Canopy Control

SECRET

UNCLASSIFIED

LOCK ON

ANT. ELEV.
DOWN UP

NOSE TAIL

TARGET REJECT

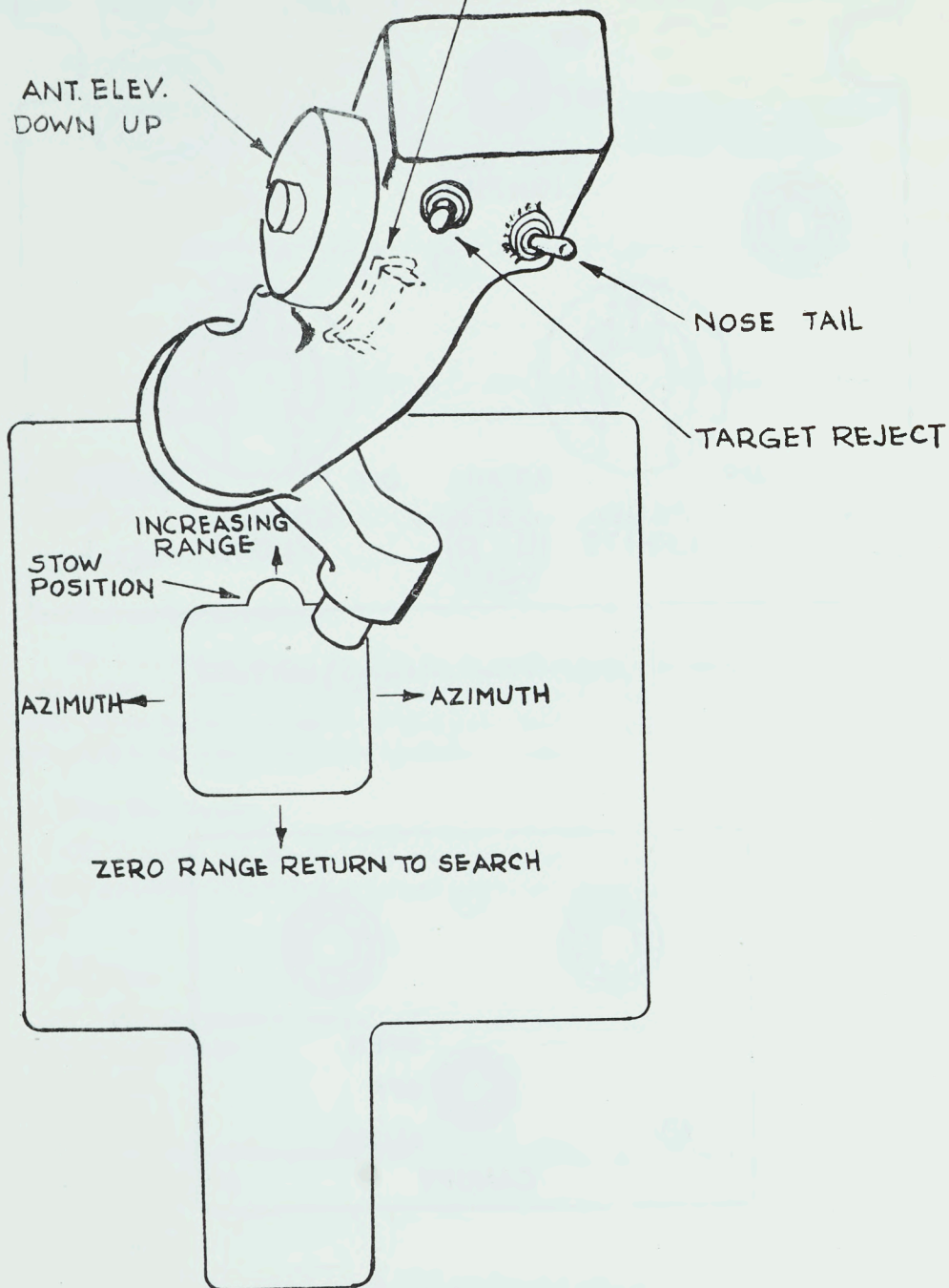

Figure 64. Radar Hand Control

UNCLASSIFIED

c. Target Reject Button

The target reject button allows the observer to reject the acquisition of one target in favor of another target with the same azimuth and elevation without returning to search.

d. Return-to-Search Switch

The return-to-search switch allows the observer to return to radar search after target acquisition in the event that the radar loses track or that the acquisition of another target is desired. This switch is of the momentary spring-loaded type and is actuated by moving the hand control grip to the full aft position.

e. Antenna Elevation Control

An antenna elevation control thumb-wheel mounted on the hand-grip control allows the observer to trim the antenna elevation angle for optimum radar performance in both the ground and observer-programmed mode of antenna scan. When used as a trimmer in the ground-programmed antenna scan, the thumb wheel has limits of ± 6 deg.

f. Lock-On Trigger Switch

The lock-on trigger switch allows the observer to acquire and automatically track the radar or IR return of the target.

Secret

UNCLASSIFIED

UNCLASSIFIED

Secret