

QCX
Avro
CF105
72-Sys.26-8

JUNE 1957 ANALYZED SECRET

Classification cancelled / Changed to UNCLASS

By authority of **ARROW 2** ARS

Date **ARMAMENT SYSTEM** 31 Sept 58

Signature DB **REPORT No. 72/SYSTEMS 26/8**

Unit / Rank / Appointment ARS

ENGINEERING DIVISION



AVRO AIRCRAFT LIMITED

Classification cancelled / Changed to UNCLASS
By authority of AVRS
Date 30 Sept 88
Signature DB [illegible]
Unit / Rank / Appointment AVRSS

SECURITY WARNING

ANALYZED

This document is classified "~~SECRET~~" and is intended solely for the use of the recipient and such persons as have been delegated to use it in the course of their duty and may only be used in connection with work performed for or on behalf of Her Majesty's Canadian Government.

The unauthorized retention or destruction of this document or disclosure of its contents to any unauthorized person is forbidden.

Failure to comply with any of the above instructions is an infraction of the Official Secrets Act.

Any unauthorized person obtaining possession of this document, by finding or otherwise, must forward it, together with his name and address, in a registered envelope, to the Engineering Division, AVRO Aircraft Ltd., Malton, Ontario, Canada.

This is copy number 72
Issued to
Date

UNCLASSIFIED
Classification cancelled/changed to
by authority of (date)
Signature [illegible] Rank

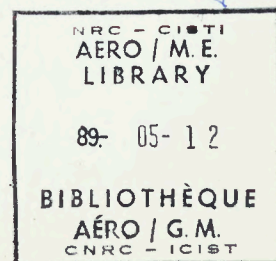

15819350

ERRATA SHEET

Armament System

Para. 3.15 Delete all after "- - at a later stage."

Para. 3.18 Missile Malfunction Indicator

Replace existing sentence with - - "This indicator will show when a missile has failed to fire after it has received a firing pulse."

Para. 5.1 Replace - "and Missile Malfunction indicators" with "indicator".

ARROW 2 ARMAMENT SYSTEM

REPORT NO. 72/SYSTEMS 26/8

JUNE 1957

This brochure is intended to provide an accurate description of the system(s) or service(s) for purposes of the Arrow 2 Mock-up Conference, and is not to be considered binding with respect to changes which may occur subsequent to the date of publication.

COMPILED BY

Jan S. Craig

APPROVED BY

Alan R. Bulay

ENGINEERING DIVISION

AVRO AIRCRAFT LIMITED

MALTON — ONTARIO

FOREWORD

On an aircraft there are many aspects of the design which, after adequate preliminary work, can be firmly specified and described with little chance that later development work will result in any change.

It is the experience of Avro Aircraft Limited, that armament installations do not fall into this category. An armament installation evolves throughout the various stages of preliminary design, analysis, detail design, ground test and flight test. The Sparrow 2D installation is currently between the detail design and ground test phases of its evolution. This brochure describes the installation as it currently appears. Later work will result in changes which cannot presently be foreseen. No decisions, which would render the making of these changes more difficult, should be made on the basis of the contents of this brochure.

TABLE OF CONTENTS

SECTION	TITLE	PAGE
1.0	Introduction	1
2.0	The Sparrow 2D Missile	2
3.0	General Description of the Installation	3
3.1	Missile Configuration	3
3.2	Attack Modes	3
3.3	Operating Envelope	4
3.4	The Pack Concept	5
3.5	Pack Structure	6
3.6	Extension Mechanism	6
3.7	Launcher	7
3.8	Wing and Fin Doors	8
3.9	Drag Link Doors	9
3.10	Hydraulic Systems	9
3.11	Electrical Power Supplies	10
3.12	Electrical Control Circuits	11
3.13	Missile Auxiliaries	11
3.14	Cooling	12
3.15	Protection of Exposed Portions of the Missile	12
3.16	Sealing	13
3.17	Services Connections to Pack	13
3.18	Cockpit Controls and Indicators	15
3.19	Missile Preparation for Firing	16

UNCLASSIFIED

TABLE OF CONTENTS (Cont'd)

SECTION	TITLE	PAGE
3.0 (Cont'd)	3.20 Missile Jettisoning	17
	3.21 Installation Weight	18
4.0	Missile Launch	20
	4.1 Salvo Type	20
	4.2 Salvo Effectiveness	20
	4.3 Missile Firing Order	21
	4.4 Firing Circuit	21
5.0	Flight Operation of the Installation	23
	5.1 Lead Pursuit Mode	23
	5.2 Lead Collision Mode	24
	5.3 Optical Mode	24
6.0	Servicing and Ground Handling	25
	6.1 Dolly Hoist	25
	6.2 Lifting Wire Attachments	25
	6.3 Changing a Pack	25
	6.4 Hydraulic System	27
	6.5 Pack Interchangeability	27
	6.6 Rear Attachment	28
	6.7 Forward Attachment	29
	6.8 Firing Circuit Safety	29
	6.9 Pack Servicing	30
	6.10 Rearming on the Aircraft	30

TABLE OF CONTENTS (Cont'd)

SECTION	TITLE	PAGE
7.0	The Development Program	31
7.1	Design Confirmation Tests	31
7.1.1	Pack Seal Test	31
7.1.2	Mechanism Wear Test	31
7.1.3	Launcher Rail Test	31
7.1.4	Electrical Breadboard	31
7.1.5	Door Test Rig	32
7.1.6	Single Missile Test Rig	32
7.1.7	Mock-Up	32
7.2	Missile Launch and Jettison Tests	32
7.3	Launchers	32
7.4	Test Packs	32
7.5	Flight Development	33

UNCLASSIFIED

LIST OF ILLUSTRATIONS

FIGURE	TITLE	PAGE
1	The Sparrow 2D Missile	35
2	Missile Configuration	36
3	Pack Structure	37
4	Missile Extension Mechanism	38
5	Wing Doors	39
6	Fin Doors	40
7	Hydraulic Actuation Single Missile	41
8	Pack Seals	42
9	Missile Seals	43
10	Missile Pack Dolly	44
11	Armament Pack	45
12	Pack and Hoist	46
13	Rear Attachment	47
14	Front Attachment	48



1.0 INTRODUCTION

The installation consists of four Sparrow 2D missiles carried in a semi-submerged position, (in a quickly interchangeable pack), under the centre fuselage of the aircraft. The missiles are mounted on launching rails, which are extended for firing.

2.0 THE SPARROW 2D MISSILE

The Sparrow 2D is a fully active K-band guided missile, weighing 430 lbs. prelaunch, which is attached to its launcher by a forward button and a rear pair of hooks (See Fig. 1).

The current model of the missile is not fully compatible with the ARROW 2 in that it was designed for carriage on lower performance aircraft. In the design of the missile installation, it has been assumed that the missile will be upgraded to be compatible with the environment it will encounter when carried on the ARROW.

Future development will determine the optimum compromise between missile modification and aircraft modification to ensure full compatibility. Proposals have been made to the RCAF for these studies to be undertaken.

3.0 GENERAL DESCRIPTION OF THE INSTALLATION

3.1 Missile Configuration (Fig. 2)

Four Sparrow 2D missiles are carried in a semi-submerged position with their centrelines on the aircraft skin line. This configuration was chosen to give an optimum extension mechanism and a practical mounting structure.

Adjacent missiles are staggered fore and aft such that two missiles are forward of the remaining pair. This configuration was caused by restrictions on fuselage width which made it necessary to alternate the wings and fins of adjacent missiles.

Missiles are carried with their wings and fins at 45 degrees to the aircraft skin line. This configuration was chosen to ensure maximum stiffness of the launching mechanism. On other armament installations it has been found that launching mechanism stiffness is a prerequisite for successful launch.

3.2 Attack Modes

Provision is made to attack with either the two rear missiles or the two forward missiles, or to attack with all four missiles. Provision is made for either automatic or manual attacks using the full facilities of the fire control sub-system, and for optical attacks.

3.3 Operating Envelope

The installation is designed to permit carriage of the missiles in the stowed position, at all speeds and accelerations within the flight envelope of the aircraft. Lowering and extended carriage of missiles, is permitted at all speeds within the flight envelope and at normal accelerations between $-1g$ and $+4g$.

This envelope was chosen after investigation had disclosed that considerable weight saving would result from a reduction in normal acceleration below that of which the aircraft is capable. As $+4g$ might well be exceeded in a breakaway manoeuvre on an actual attack, it is intended that any missile which has not fired at the end of an attack sequence will be jettisoned automatically before the normal acceleration exceeds $+4g$. This automatic jettison feature can be disabled for training missions when it can be guaranteed that the operating limits for extended carriage will not be exceeded.

For retraction of empty launchers, the system is designed for all speeds and accelerations within the aircraft flight envelope.

For retraction of hangfires on training missions, the system

is designed to retract at any speed and at normal accelerations between - 1 and + 2g. Should the acceleration exceed + 2g, but be less than + 4g, the missile will pause in its motion until the acceleration is once again within limits.

3.4 The Weapon Pack Concept

When the basic aircraft configuration was being laid down, several different weapons were considered for use with the aircraft. Each of these weapons required a different carrying structure. In order to finalize the design of the fuselage, it was decided that it would be designed to accommodate an armament pack. All flight induced loads would be carried by the fuselage and the pack structure would carry only the loads induced by the armament itself. In this way, changes of weapon could take place without seriously changing the basic aircraft.

It was determined that requirements for cleaning, checking circuits, and individual loading of missiles resulted in the specified rearming period being exceeded. It was decided that to meet the requirements, rearming should be carried out by pack interchange. The pack was therefore designed as a rapidly interchangeable item. An incidental advantage accruing from this decision is that armament installation unserviceability no longer means aircraft unserviceability as a serviceable pack can be rapidly installed in place

of an unserviceable one.

3.5 Pack Structure

The pack structure consists of longitudinal and transverse members as shown in Fig. 3. The pack is attached to the fuselage at its four corners by bomb release type attachments. Vertical loads are taken out by all four attachments. Fore and aft loads are taken out by the rear attachments only. Side loads are taken out on one front attachment and one rear attachment. These attachments have been designed such that true interchangeability will be attained.

3.6 Extension Mechanism

The missiles are mounted on rail type launchers which must be extended to the firing position. It is a requirement that all four missiles shall be extended for launch at the same time. Because of the proximity of the wings and fins of adjacent missiles, the rear pair of missiles are extended further than the forward pair of missiles as shown in Fig. 2. In this way, any missile can be launched without fouling any other missile.

A twin jack with drag link mechanism was adopted after investigation had clearly shown its superiority over other mechanisms. This mechanism is shown in Fig. 4. The

two jacks are synchronized and regulate vertical distance below the skin line, while the drag link, which is a rigid member, regulates fore and aft position.

In order to minimize the period in which the launchers are extended, the extension time was also minimized consistent with availability of power and missile strength. The selected extension time is 1.25 seconds.

Considerations of minimum weight and practicability resulted in the choice of the utility hydraulic system as the source of power for the extension system. In the course of the design, it was determined that small diameter hydraulic jacks would satisfactorily take out end loads. After further investigation, these jacks were housed in telescopic structural members designed to take out lateral loads.

Missiles are held in the launch position by hydraulic pressure. Missiles are held in the retracted position by hydraulic pressure and by a hydraulically actuated up-lock.

3.7 Launcher

After launch, the gap in the skin previously occupied by the missile is filled by retracting the launcher part way. The launcher itself is of the same planform as the missile, and therefore seals the gap.

AVRO ARROW
UNCLASSIFIED

The Sparrow 2D is rail launched. The captive travel in the ARROW installation has been made as long as possible (60 inches) in order to permit firing of one missile adjacent to another without encountering trouble due to wing and fin collisions.

The missile may be jettisoned from the launcher by dropping. The portions of the rail on which the missile rests in its prelaunch position are attached to the launcher by explosive bolts.

The missile is prevented from moving forward by a hook which is held in position by a shear pin. This pin will break when the thrust of the missile motor builds up to 3000 lbs (7g).

3.8 Wing and Fin Doors

In order to extend the missile for launch, it is necessary to open doors to permit the wings and fins to pass through the skin line. Multi-element sliding doors were adopted. These doors are hydraulically actuated and run on rollers in tracks as shown in Figs. 5 and 6. Each pair of wing or fin doors, which open or close in approximately 0.35 seconds, is actuated by a hydraulic jack. The doors are opened for missile extension and closed during firing. They are reopened during launcher retraction and closed when the launcher has been retracted.

3.9 Drag Link Doors

In the case of a forward missile, the drag link swings in an arc such that it passes through the gap left by the missile body in the pack skin line.

In the case of a rear missile, the drag link passes through the skin line ahead of the body gap. Ahead of each rear missile there is provided a pair of short chord, hinged, inwardly opening doors actuated by a single jack. These doors are opened prior to missile extension and closed after launcher retraction.

3.10 Hydraulic System

All actuation is hydraulic. Oil is supplied through quick disconnect fittings, at the rear of the pack, from the utility hydraulic system. This system contains two 20 gpm pumps delivering oil at 4,000 psi. This supply is used directly in the pack, no accumulators being provided. Electrically controlled valves are used throughout, sequenced by hermetically sealed micro switches.

Aerodynamic and inertia loading on the missiles is such that, under almost all conditions, the forward extension jack is in compression while the rear jack is in tension. On the rare occasions when one or both of these loads are reversed, the magnitude of the reversal is small. This

peculiarity of loading has enabled the adoption of a variant of the Exactor control for missile extension and retraction.

For extension, oil from the pump is delivered to the head end of the rear jack, causing oil to be expelled from the annular end of the rear jack. This oil is piped to the head end of the forward jack. The annular volume of the rear jack matches the head volume of the forward jack, hence, these two jacks move in synchronism. At the end of each stroke, the "series" hook-up is changed to a parallel one, and pump pressure is applied directly to each jack. A diagram of the hydraulic actuation of a single missile linkage is shown in Fig. 7.

On the ground, with the engines stopped, hydraulic power for door and missile actuation will be obtained by connecting a ground hydraulic supply into the normal utility system ground connections.

3.11 Electrical Power Supplies

Electric power for control of door operation and missile extension comes from the emergency DC bus, which is energized at all times except when the aircraft is on the ground with engines stopped and ground power supply disconnected.

Electric power for missile jettisoning also comes from the

emergency DC bus but is fed through an interlock so that power will not reach the explosive bolts unless weight is off the nose undercarriage leg.

Electric power for missile firing comes from the main DC bus and is fed through an interlock so that power cannot reach the firing circuit until all undercarriage legs are up and doors are closed.

Electric power for missile preparation comes from the main buses which are energized whenever the engines are running or the ground supply is plugged in.

3.12 Electrical Control Circuits

The relay network associated with door opening and closing and missile extension, and the network associated with missile firing and jettison are located at the forward end of the pack between the two inboard missiles.

3.13 Missile Auxiliaries

The missile auxiliaries associated with the preparation of the missiles for launch are located at the forward end of the pack, in the bays between the inboard and outboard missiles. It is intended that the auxiliaries will stay with the pack and that, when a new pack is installed, its auxiliaries will not require any additional adjustment.

3.14 Cooling

Discharge air from the cockpit is used for "area cooling" of the pack. Air from the equipment cooling supply of the air conditioning system is used to cool the missile auxiliaries. When the pack is installed in the aircraft, these two supplies are automatically connected.

The cockpit discharge air enters a gallery pipe running athwartships at the forward end of the pack. Outlets are provided into each missile bay, and the air is exhausted to atmosphere at the rear end of each bay. This air will maintain the general temperature level in the pack between 0°F and 130°F.

Cooling air will be piped direct to the missile auxiliaries, and will be exhausted to atmosphere directly from the bays in which they are located.

3.15 Protection of Exposed Portions of the Missile

Although it is known that the present model of the missile will not withstand carriage at $M = 2.0$ for the full period of which the aircraft is capable, no attempt has yet been made to protect the missile from external temperature.

This will be done, if necessary, at a later stage.

It is necessary, however, to protect missile radomes from

stones, slush etc. thrown up by the aircraft nosewheel and from the effects of rain erosion in flight. This is accomplished by fitting fibreglass fairings over the radomes, which will blow clear on missile extension. A rear fairing, to reduce drag, is fitted to each missile. This fairing will also blow clear on missile extension.

3.16 Sealing

Particular attention has been paid to ensuring good sealing between the pack and the fuselage, and between the missiles and the pack. Considerable relative motion can take place between the pack and the fuselage. Sealing along the edges of the pack is accomplished as shown in Fig. 8. The seals are inflated when the access door to the firing circuit safety disconnect is closed and deflated when the door is opened.

Due to the large tolerances on the missile, the special seal shown in Fig. 9 was designed. This seal runs the entire length of the missile, except around the radome.

Seals around the radome and along the transverse edges of doors are not yet fully designed. Schemes exist which must be developed on the test rigs prior to design being committed.

3.17 Services Connections to Pack

The following services connect into the pack:

- (a) hydraulic oil supply and return



- (b) cooling air (cockpit discharge and equipment cooling)
- (c) pressure air for seal inflation
- (d) electric power supplies
- (e) inputs from fire control sub-system circuits

The hydraulic oil supply and return connections are of the quick disconnect type which are manually connected and disconnected. They are mounted on universal joint type swivels and are manually positioned for mating. Access is through a hinged door at the rear of the pack on the star-board side. The door is held closed by quick release fasteners.

Cooling air supplies enter the pack through the roof. The connections are automatically made as the pack is installed in the aircraft, and are of the spring loaded butting type.

Pressure air, electric power and fire control circuits enter the pack at the forward end, through a hole in the roof. Access to make and break the connections, is through a hinged door equipped with quick release fasteners, on the underside of the pack. The pressure air connection is of the quick release type. Both electric power and fire control wiring are in the same large connector which is manually inserted.

3.18 Cockpit Controls and Indicators

The following cockpit controls and indicators are provided:

- (1) On the armament control panel, which is located on the pilot's starboard console:
 - (a) A safe-arm switch - No power is applied to the firing circuits or to the missiles when this switch is in the SAFE position.
 - (b) A first pass selector switch - This switch is labelled FRONT-REAR-ALL. In the event of a first pass being made with only two missiles, the switch is rendered inoperative after these two missiles are fired. The remaining two missiles are then available for a second pass regardless of whether or not the switch is positioned.
 - (c) A mode selector switch - This switch is labelled VISUAL IDENT - LEAD PURSUIT - LEAD COLLISION - SNAP UP.
 - (d) An extend - retract switch - This switch is of the momentary contact type and is provided to extend missiles for optical attacks, and to retract hangfires on training missions.
- (2) On the master warning panel: A hangfire light is provided on the master warning panel. This light is intended to advise the pilot of hangfires. The light will



come on when the missiles start to extend, and will go off when the missiles leave the launchers.

- (3) On the main panel:
 - (a) A missile ready indicator. This indicator will show when one or more of the selected missiles are locked on to the target.
 - (b) A missile malfunction indicator. This indicator will show when one or more of the selected missiles are not locked on.
 - (c) A stores jettison switch. This switch is used to jettison the external tank or missiles.
- (4) On the control column - A trigger is provided on the control column. This trigger enables firing pulses to reach the selected missiles.

3.19 Missile Preparation for Firing

Missiles can be carried on the aircraft in four conditions:

- (1) OFF - In this condition, now power is applied to the missile. Missiles will normally be carried in this condition until an attack is committed.
- (2) Condition 1 - In this condition, the missile is readied for extension and immediate lock on. The current minimum time for condition 1 is 2 minutes. During this period: power is applied to the missile, the turbine motor is synchronized with aircraft power, the



antenna gyro is run up, the glow plug is energized, the thyatron filament is switched on, and the antenna is angle slaved. When condition 1 is complete, the missile is ready for extension to the firing position. The time spent in condition 1 will be kept to a minimum to avoid missile overheating.

- (3) Condition 2 - This condition is initiated when the missile is extended half way to the firing position. In this condition, the missile is transmitting, the range gates are slaved, and the missile achieves lock.
- (4) Condition 3-- This condition is initiated by a firing pulse from the intervalometer. The condition lasts while gyros are uncaged, and the missile is transferred to internal power. When this sequence is complete, a control relay is automatically closed to apply power to the igniter.

3.20 Missile Jettisoning

A missile can be jettisoned by exploding bolts in the launcher which will disconnect the portions of launcher track to which the missile is attached and allow it to drop.

Wind tunnel tests have been carried out to establish jettisoning techniques. In an emergency, when it is desired to jettison all four missiles from the stowed position, the

stores jettison control in the cockpit is actuated, the doors will open and all four missiles will extend to the firing position. The explosive bolts in the rear launchers (lower missiles) will be exploded simultaneously. As soon as the missiles are clear, the rear launchers will retract in order to give the forward missiles a clear jettisoning path. As soon as the rear launchers are clear, the forward missiles will be jettisoned in a similar fashion to the rear missiles. The forward launchers will then retract.

Following a two-missile attack, on which one missile fails to fire, the hangfire will be automatically jettisoned, and the empty launchers will be retracted.

Following a four-missile attack on which one missile fails to fire, it will be automatically jettisoned. If the hangfire is on a rear launcher, it will be jettisoned forthwith, and all four launchers will be retracted. If the hangfire is on a forward launcher, the rear launchers will be retracted sufficiently to give the hangfire a clear jettisoning path, and it will then be jettisoned, followed by retraction of the remaining launchers.

3.21 Installation Weight

An armament pack complete with four Sparrow 2D missiles

is expected to weigh 3726 lbs. This weight is broken down as follows:

Structure	-	875 lbs
Hydraulics	-	332 lbs
Mechanisms	-	583 lbs
Electrical	-	64 lbs
Missile auxiliaries	-	143 lbs
Missiles	-	<u>1,728 lbs</u>
Total		<u>3,726 lbs</u>



4.0 MISSILE LAUNCH

4.1 Salvo Type

When guidance cuts in, shortly after launch, the Sparrow 2D has a tendency to go into a considerable manoeuvre. In order to minimize the risk of mid-air collisions, missiles are fired in train. To maximize the effectiveness of a salvo, the interval between missiles should be kept to a minimum. One-half second has been chosen as the interval.

4.2 Salvo Effectiveness

Within its design envelope, the Sparrow 2D can be fired, with roughly constant effectiveness, from a certain volume of space. Outside this volume, missile effectiveness falls off sharply. At the higher altitudes and against higher performance targets, this volume shrinks. Placement problems may result in the interceptor cutting across a corner of such a volume. In order to maximize effectiveness, a salvo should be concentrated into the minimum period of time possible. For this reason, a 4 x 4 system has been adopted.

In the 4 x 4 system, angle and range slaving of all four missiles is done simultaneously. All four missiles are extended simultaneously at the beginning of the attack. All four missiles can, therefore, be fired at half second intervals.

Information available to AVRO indicates that a serviceable



missile with serviceable auxiliaries, and within missile radar range, will lock on to a target within one half second of sighting it. Any missile, which has not locked on to a target in a period slightly greater than one half second, will probably never achieve lock because it is itself unserviceable, or because its associated equipment is unserviceable. If not fired as a rocket, the missile becomes a hangfire, and will ultimately be jettisoned. The firing circuit should not, therefore, lose any time waiting for missiles to lock, but should, after a reasonable period, fire the missiles.

4.3 Missile Firing Order

The installation is designed so that missiles may be launched in any order.

4.4 Firing Circuit

One half second after the first missile achieves lock, an intervalometer will start generating firing pulses. These pulses will be routed to each missile in turn and in a fixed order. If, at the time of receiving a firing pulse, a missile has achieved lock, it will fire. If the missile has not achieved lock, it will remain on its launcher. The intervalometer will continue to generate pulses until the aircraft has closed to a range at which it is apparent that there is little hope of any of the remaining missiles achieving lock. At this time an override will be operated which will route



future pulses to the motor ignitors, bypassing the interlocks within the hangfire missile(s). In the unlikely event that a hangfire remains after this operation, it will be automatically jettisoned.

Since information on the variation in lock on range between individual missiles is not yet available, the circuit design can not be finalized. When this information is available, the design will be in accordance with the foregoing philosophy.

5.0 FLIGHT OPERATION OF THE INSTALLATION

Missiles are kept in the OFF condition until entering the combat area. On selecting ARM on the safe-arm switch, power will be applied to the missiles which have been selected on the first pass selector switch, and the firing circuit will be readied. Note that the present minimum time between applying power to the missiles and firing them is two minutes. An attempt will be made to develop a method of switching on the missiles automatically in a later portion of design program. The pilot will then select the desired attack mode.

5.1 Lead Pursuit Mode

Two seconds before entering the firing area, the selected missiles will be extended to the launch position. Half way to the extended position, the missiles will be put into Condition 2. From knowledge of the attack situation as displayed on the scope and guided by the missile ready and missile malfunction indicators, the pilot can judge the most opportune time to fire. When he decides that this moment has arrived, he will press his trigger and the selected missiles will be fired at half second intervals. After all the missiles have left, the launchers will be automatically retracted until they are flush with the skin line. In the unlikely event of hangfires being present, they will be automatically jettisoned. On training missions, in the event of hangfires, all launchers will remain extended until the pilot selects retract.

5.2 Load Collision Mode

The difference between the lead pursuit mode and the lead collision mode, in addition to the type of course flown, is that the fire control sub-system will select the moment of firing. Pilot action will be the same as in the lead pursuit mode, except that he will depress the trigger prior to entering the firing zone. Firing will be initiated by the fire control sub-system, however, the attack can be aborted by releasing the trigger. Otherwise the lead collision attack sequence is identical to the lead pursuit attack.

5.3 Optical Mode

When the pilot wishes to make an optical attack, selection of OPTICAL on the mode selector switch will slave the antenna of the selected missiles straight ahead. To extend the missiles for launch, the pilot must select EXTEND on the extend-retract switch. Half way to the extended position the missiles will be put into Condition 2, when the range gates will be swept over a wide range. From this point on, the attack will proceed as in the lead pursuit mode.

6.0 SERVICING AND GROUND HANDLING

As previously described, the pack was designed for easy removal and replacement with the objective of rearming by interchange of packs. Careful attention has, therefore, been paid to the design of the pack attachments.

The pack is installed in the aircraft, removed from the aircraft, and transported on a combined dolly/hoist.

6.1 Dolly Hoist (Fig. 10)

The combined dolly/hoist is equipped with four double tire pneumatic wheels, and can be towed either forward or sideways. For hoisting the pack, there are four lifting wires which attach to the aircraft. These lifting wires are pneumatically extended and retracted by controls on the dolly. Pneumatic power is contained in bottles, which are a part of the dolly, and sufficient air is stored for six raisings and lowerings, before recharging is necessary.

6.2 Lifting Wire Attachments

Lifting wires are attached to the aircraft by hooking fittings over retractable lugs on the sides of the fuselage. These lugs are spring loaded to extend and are locked and unlocked by a half turn with a screwdriver (or a coin).

6.3 Changing a Pack (Figs. 11 and 12)

To change a pack an empty dolly is wheeled underneath the aircraft, and the lifting wires are attached to the fuselage.

By operation of the hoist controls, the dolly is lifted until it is firmly up against the package. While the dolly is being lifted the hydraulic connections at the rear of the pack, and the electrical and air connections at the forward end of the pack are broken. The pack attachments to the fuselage are then unlocked. The hoist controls can next be manipulated to lower the pack and dolly. When the dolly wheels are firmly on the ground, the lifting wires are disconnected from the aircraft and the pack and dolly can be towed away.

The dolly, with the replacement pack, can then be wheeled under the aircraft and the lifting wires attached. By operation of the hoist controls, the pack can then be lifted vertically into the armament bay. Guide rails, on the rear pack attachment, mate with rollers on the aircraft part of the rear attachment. If the pack has been correctly placed on the dolly, the guide rails will mate with the rollers automatically. If however, the pack has not been correctly placed on the dolly it will be necessary to manhandle it to get the guide rails to engage. Retractable handling bars are provided at the rear of the pack. Once the rails are engaged in the rollers, hoisting can continue and all four attachments will mate automatically. The attachments are then locked and the dolly can be lowered to the ground. During dolly lowering, the hydraulic, electrical and air connections can be made and

the access doors to them closed. When the dolly is on the ground, the lifting wires are disconnected and the aircraft lugs locked in the retracted position. The dolly can then be wheeled away.

Trials with mock-up packs have resulted in pack interchange times of less than $3\frac{1}{2}$ minutes.

6.4 Hydraulic System

When the pack is removed from the aircraft, changes of temperature will result in changes in the volume of the oil in the hydraulic system. A relief valve is fitted such that pressure can be relieved in the event of a temperature rise. A drop in temperature will result in cavitation.

It is not anticipated that cavitation will cause any problems. If, however, cavitation should later prove to be a problem, a reservoir which would be a piece of ground equipment, would be required. This reservoir would mount on top of the pack and connect into the hydraulic system at the connections at the rear of the pack.

6.5 Pack Interchangeability

In the design of the installation, particular attention was paid to pack interchangeability. The rear pack attachments mate with fixed fittings on the aft bulkhead of the armament bay.

One of these fittings takes load in all three planes, and is,

therefore, a snug fit. On installing a pack, engagement of the guide rail will ensure correct mating. The other rear fitting takes only vertical and fore and aft loads. There is adequate lateral clearance in this fitting to allow for tolerances and temperature changes.

The forward pack attachments mate with swinging link attachments in the aircraft. The swinging links are spring-loaded to their theoretically correct position. The pack attachments contain leads which will engage with the links, as the pack is being offered up, and which will guide the links into the forward attachments.

6.6 Rear Attachments

These attachments are of the bomb release type. They are manually actuated both to close and open. To unlock, a screwdriver is inserted in the locking bar and pushed hard home to remove the detent from the hook attachment. The screwdriver is then turned to unlock the hook.

To lock the attachment, the screwdriver is inserted in the locking bar and turned. This will lock the hook. When the bar has been fully turned, the screwdriver should be removed, and the bar will spring out until one end is flush with the skin line. When the end of the bar is flush with the skin, the hook detent is fully home and the attachment is secure.

6.7 Forward Attachments (Fig. 14)

These attachments are of the bomb release type. They are manually actuated to close and open. To unlock, the detent is pressed in and the lever pulled. To lock, the lever is pressed in until it engages with the detent. A small tab is attached to the hook which, when flush with the skin line, forms visual evidence that the hook is home.

6.8 Firing Circuit Safety

Towards the rear of the pack, on the port side, there is a hinged panel held closed by two Hartwell latches. When this panel is closed, it depresses a plunger which, through relays, permits electric power to enter the pack. When the door is open the plunger is released, thus removing all power from the pack. That the door is open is evidence to ground personnel that there is no danger of inadvertent actuation of doors or missiles. For door operation and missile extension or retraction on the ground, the plunger may be manually depressed. Adjacent to the plunger are manual extend and retract switches.

The access door also gives access to the firing and jettison circuit safety plug. The final link in each missile firing and jettison circuit is led through the safety plug which should be disconnected at all times when the aircraft is on the ground.

The plug itself is on a chain, and can hang clear of the



pack as evidence of fitting and jettison circuit safety.

6.9 Pack Servicing

When it is separated from the aircraft, it is intended that the pack shall be serviced in a stand. This stand would contain replicas of the aircraft pack attachments and lifting wire attachments and would also have hydraulic and electric power supplies.

In the stand, the pack could be cleaned after firing, inspected and functioned. Test boxes to check out the auxiliaries, the actuation circuitry and the firing circuitry will be required.

6.10 Rearming on the Aircraft

Although rearming by replacing individual missiles will not meet the turnaround requirements, it is recognized that occasions may arise when it is necessary to rearm on the aircraft. The single missile hoist, which was designed for use with the CF-100 MK. 6, can be used for loading single missiles on to the pack while it is installed in the aircraft.

7.0 DEVELOPMENT PROGRAM

As stated in the foreword, the evolution of an armament installation cannot be broken down rigidly into design and test. Right up to the moment that an installation goes into squadron service the design is being continually refined. The means of refining the design is the development program.

7.1 Design Confirmation Tests

Several tests will be carried out in the near future to confirm design decisions. These tests will not be complete before the first pack details have been made. They will however, give the necessary lead time for re-design, should the decisions prove to be unsound.

7.1.1 Pack Seal Test

This will be a full scale test of the front pack seal.

7.1.2 Mechanism Wear Test

This will be a life test on the extension mechanism structural telescopic member.

7.1.3 Launcher Rail Test

This will be a wear test on a launching rail giving sixty inches of captive travel.

7.1.4 Electrical Breadboard

This will be a test of the soundness of the design of the actuation and firing circuits.

7.1.5 Door Test Rig

This will be a test of the soundness of the design of the sliding wing doors.

7.1.6 Single Missile Test Rig

This will be a test of the extension mechanism of a single missile. Simulated loading will be applied during actuation.

7.1.7 Mock-Up

The mock up pack will be used to check out assumptions made during the design of the pack.

7.2 Missile Launch and Jettison Tests

Wind tunnel tests have already been carried out on missile launch and jettison. Further work, yet to be done, consists of interpreting the results. These results will be used in establishing missile trajectory and in confirming the loading on the launch mechanism and that the stiffness, as designed, is satisfactory.

7.3 Launchers

The launchers, although based on a Douglas Aircraft Company design, are new items. They will be subjected to simulated firing, actual firing, strength, stiffness, vibration, and environmental tests in addition to jettison tests.

7.4 Test Packs

Three test packs will be built. The first pack will be used only on the ground. The third pack will be used only in the



air. The second pack will be used for some ground tests prior to being used in the flight program. The ground program will consist of:-

- (a) A period in which the servicing and maintenance features can be assessed.
- (b) a check on the launching mechanism stiffness
- (c) functioning tests without simulated loading
- (d) functioning tests at high and low temperature
- (e) vibration tests
- (f) firing tests with simulated aircraft structure ahead of and behind the pack. These tests will combine the ground firing tests, which, on previous similar installations, have been carried out on both component and the aircraft.
- (g) leakage tests on seals
- (h) structural strength

7.5 Flight Development

Flight development will be carried out on aircraft number 3 after completion of the damping system development. The program will roughly follow this pattern:

- (a) integrity-missiles retracted
- (b) integrity-missiles extended
- (c) integrity-raising and lowering
- (d) jettison

UNCLASSIFIED
AVRO ARROW

- (e) firing-subsonic
- (f) firing-supersonic
- (g) firing-transonic

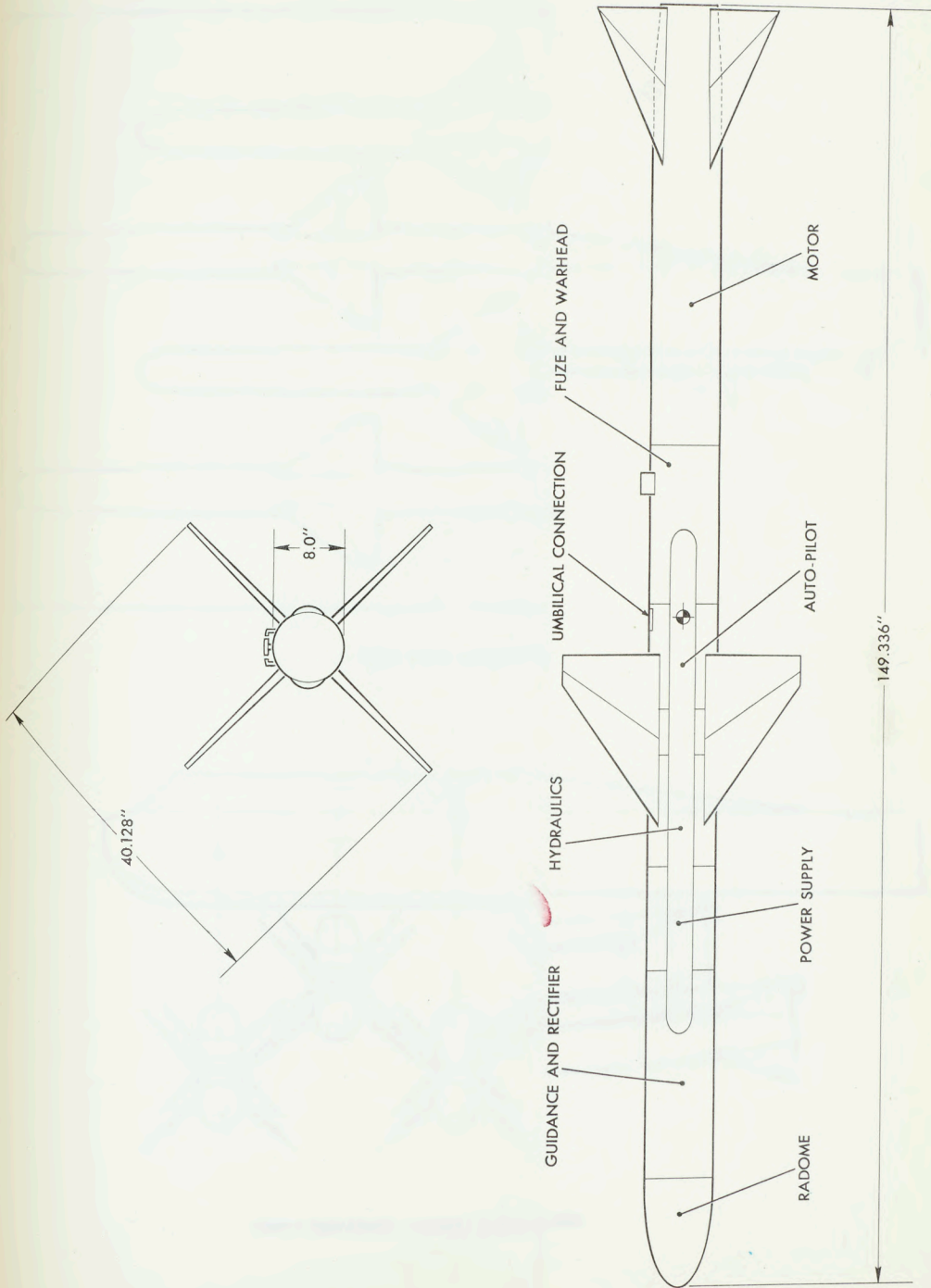
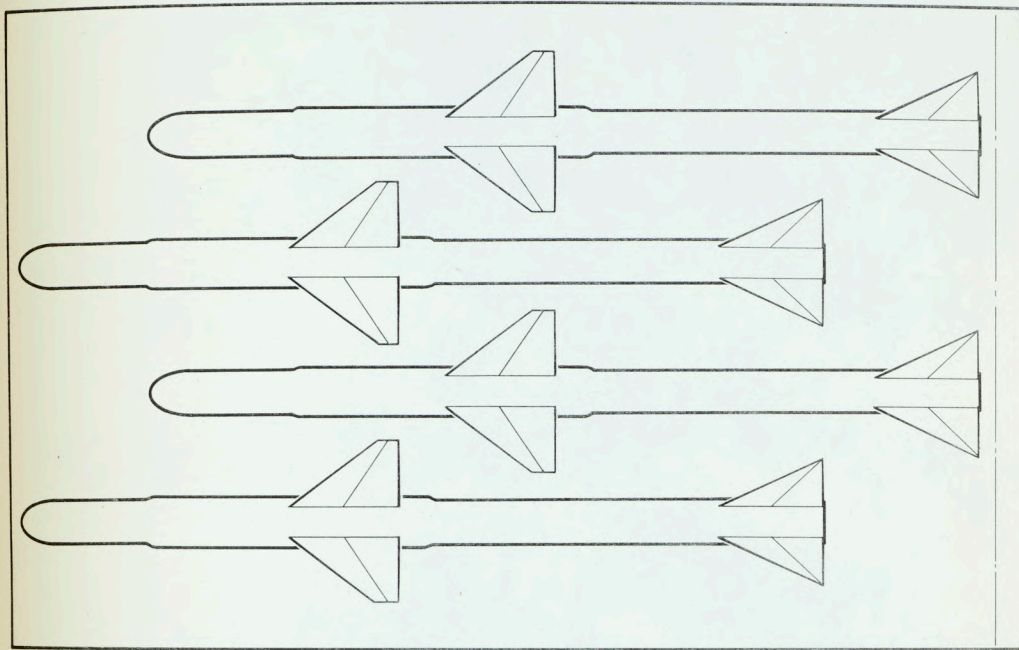
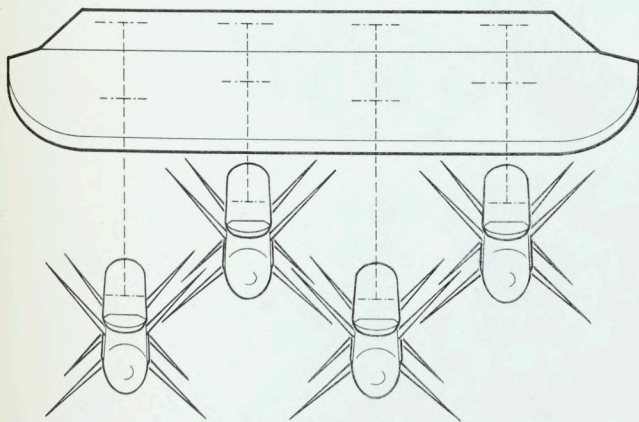

FIG. 1 THE SPARROW 2 MISSILE

/8



PLAN VIEW - MISSILES STOWED



FRONT ELEVATION - MISSILES EXTENDED

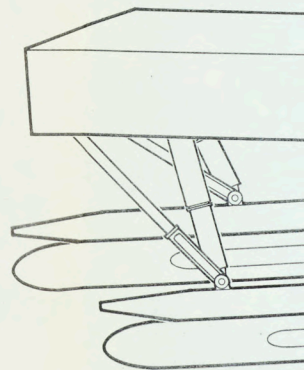
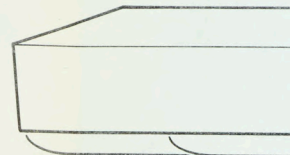
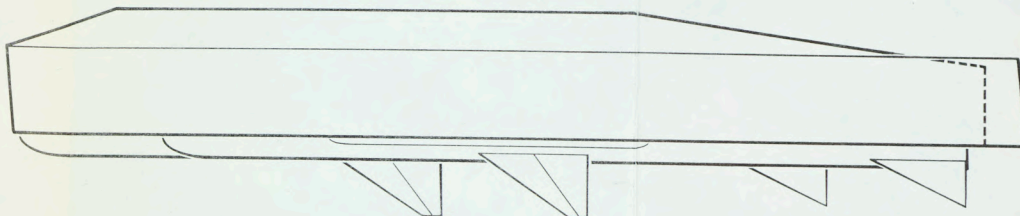
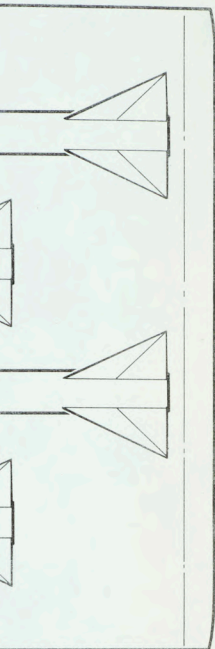
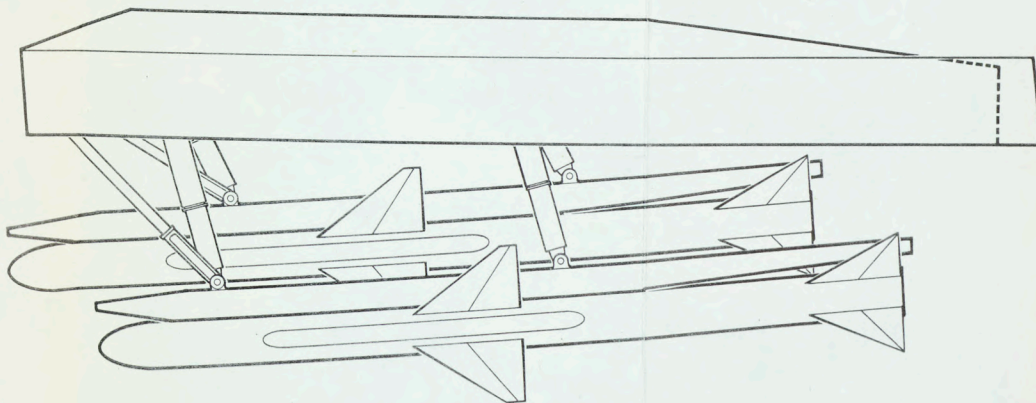

FIG. 2 MISSILE CONFIGURATION



SIDE VIEW-MISSILES STOWED



SIDE VIEW-MISSILES EXTENDED

FIG. 2 MISSILE CONFIGURATION

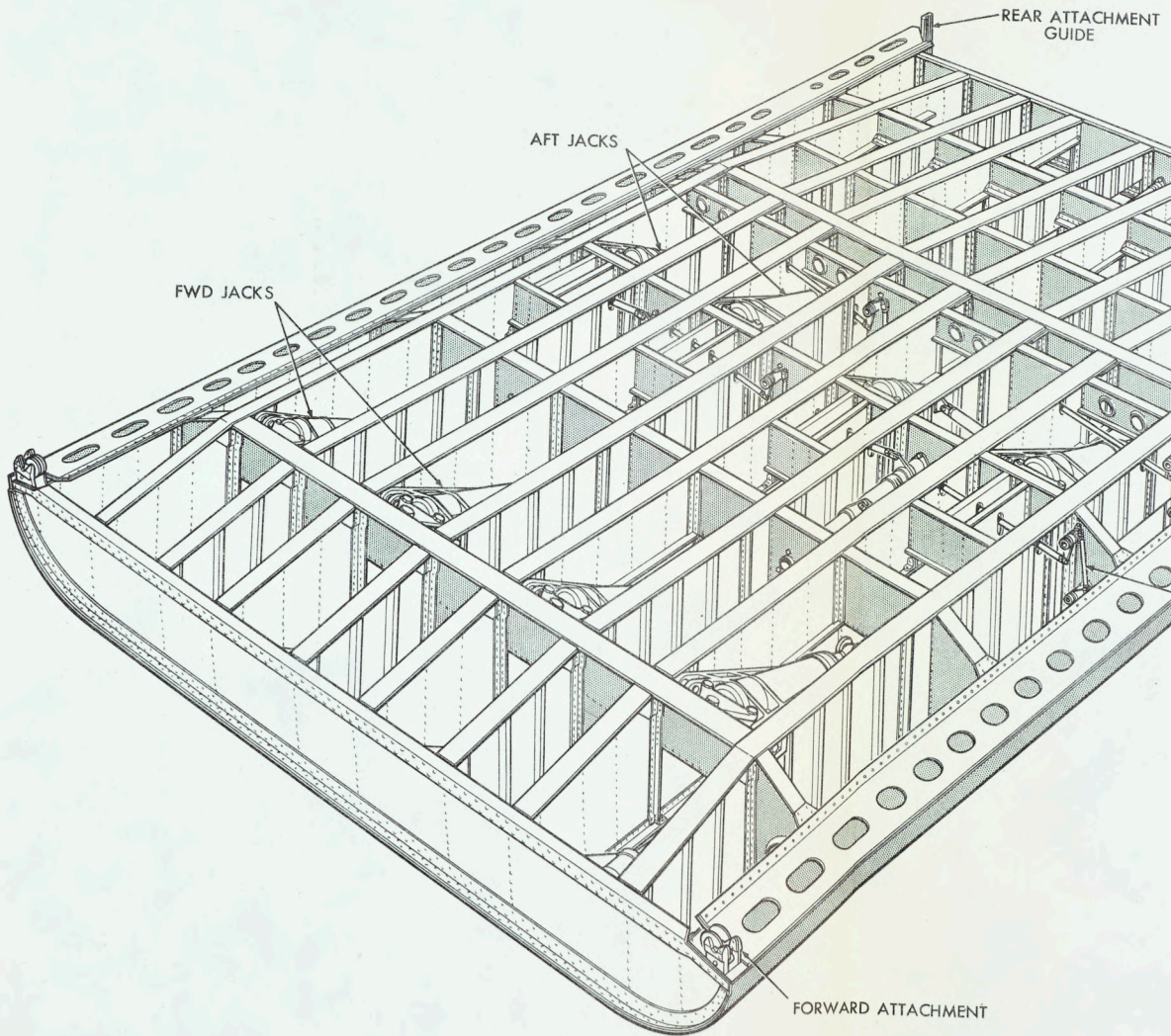

FIG. 3 PACKAGE STRUCTURE

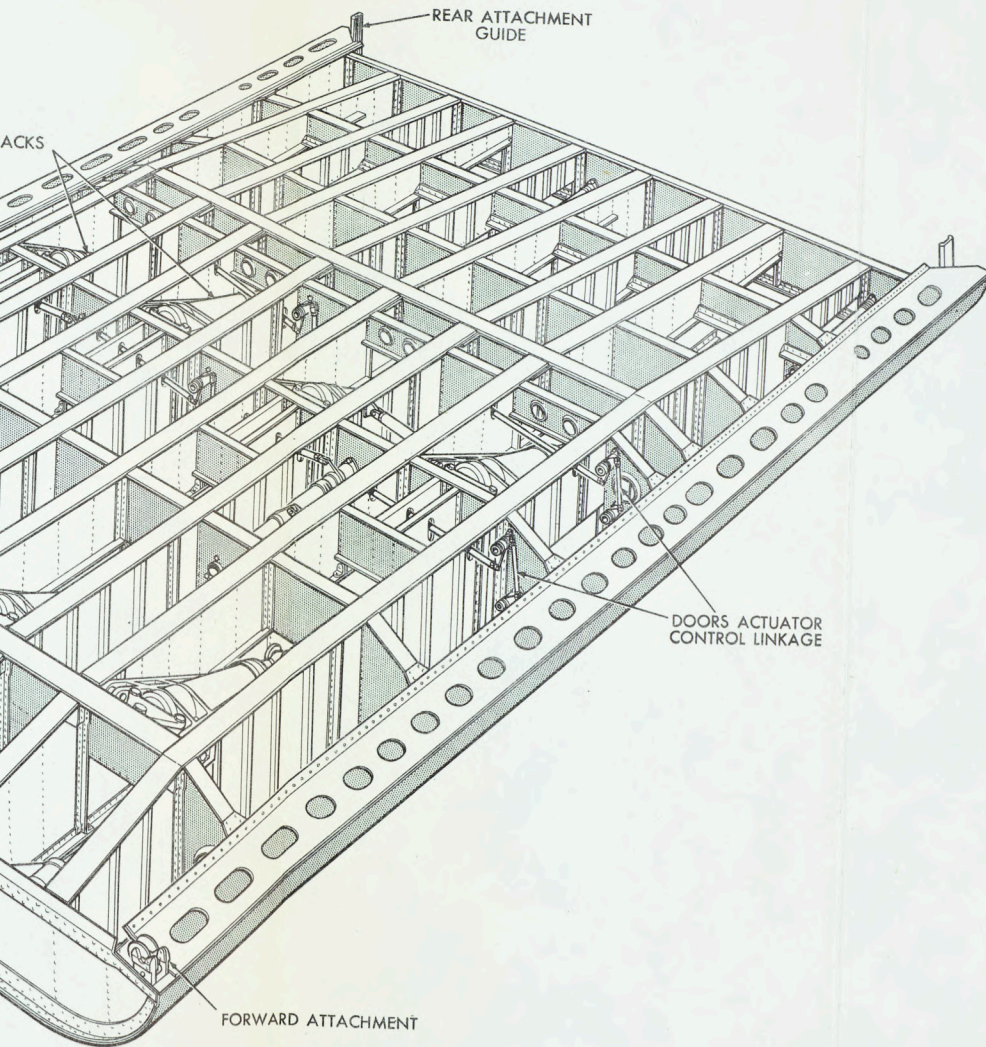

FIG. 3 PACKAGE STRUCTURE

H61-129-3

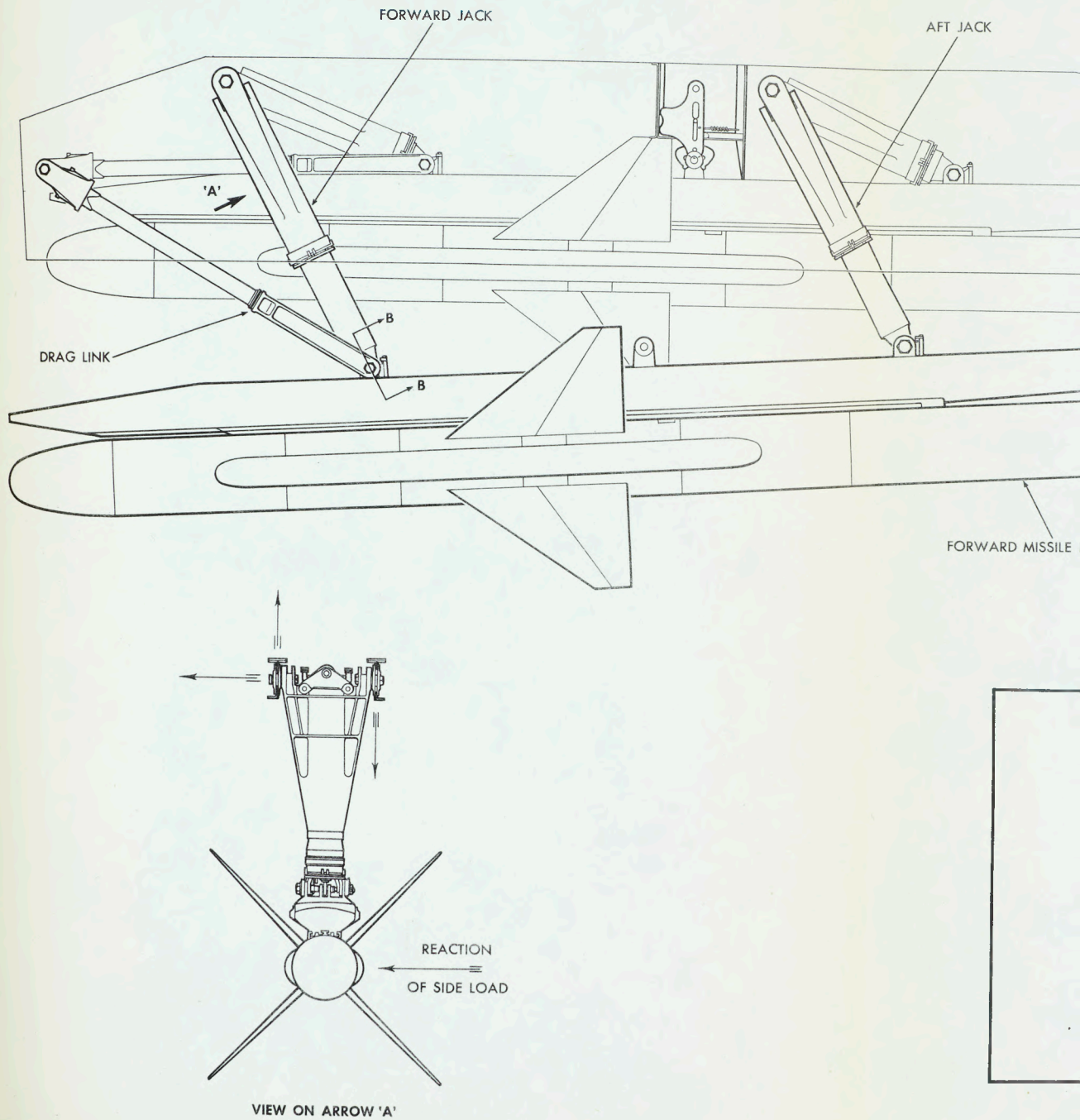

FIG. 4 MISSILE EXTENSION MECHANISM

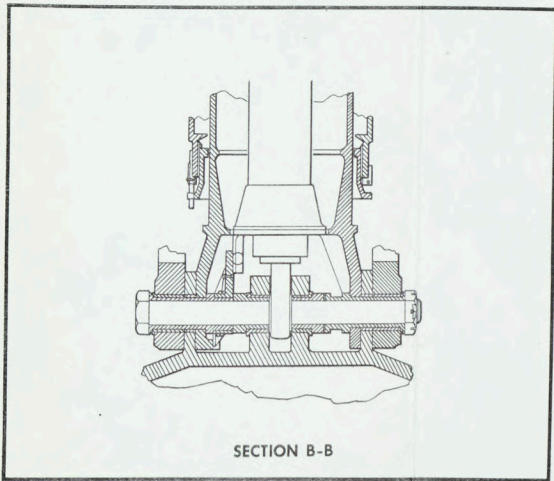
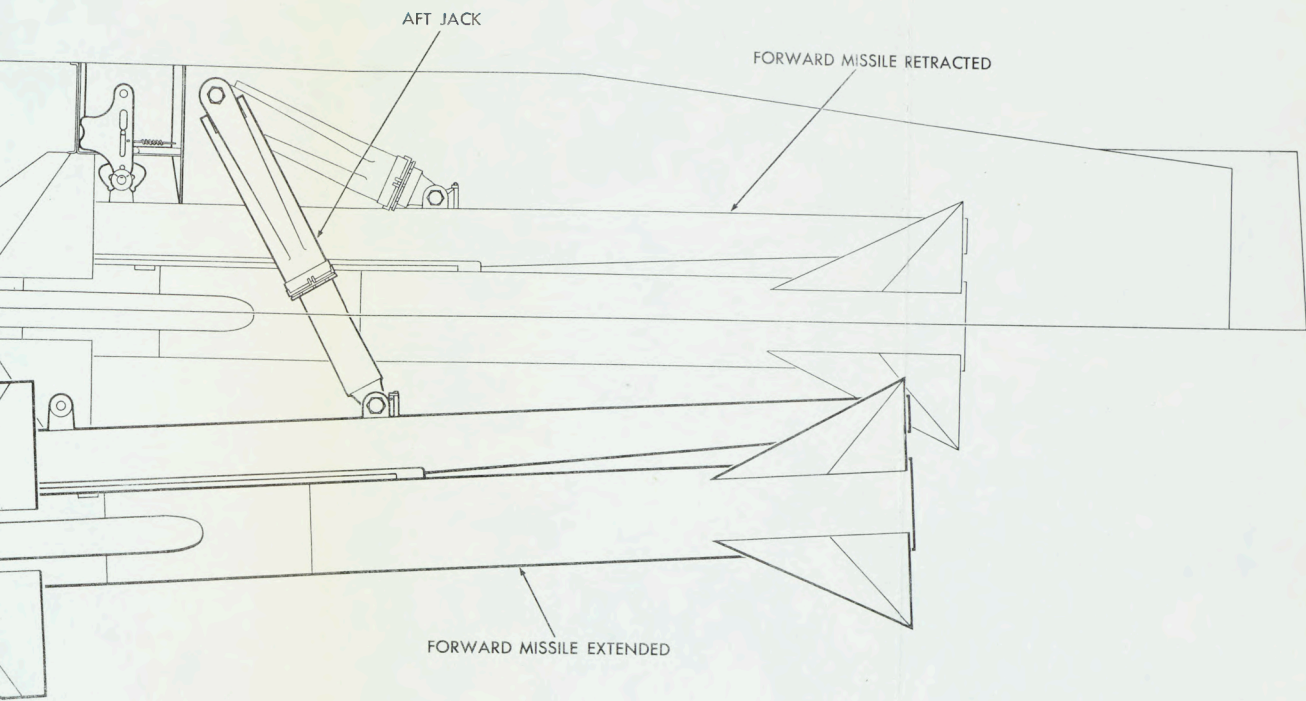

FIG. 4 MISSILE EXTENSION MECHANISM

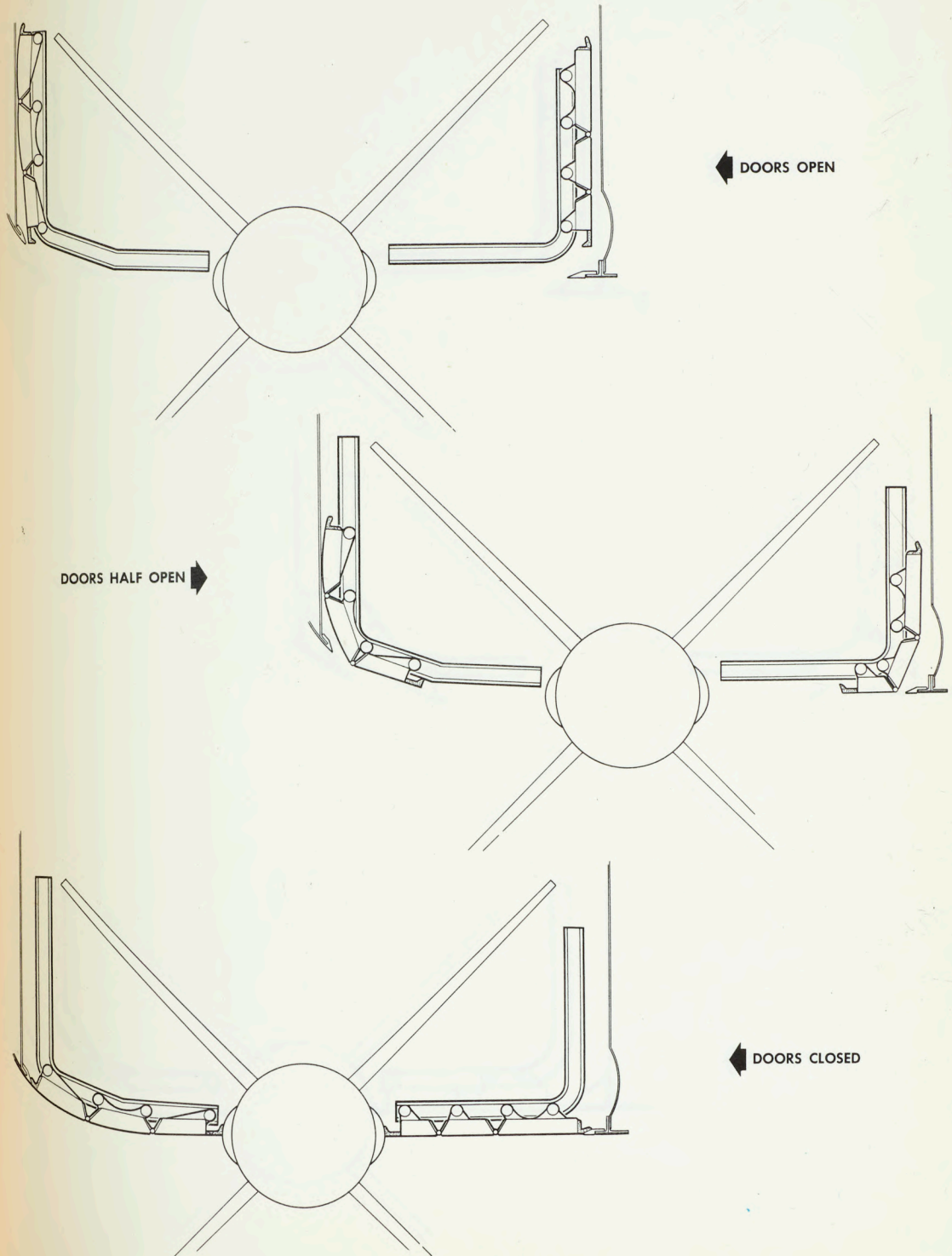

FIG. 5 MISSILE WING DOORS



2570-209-1

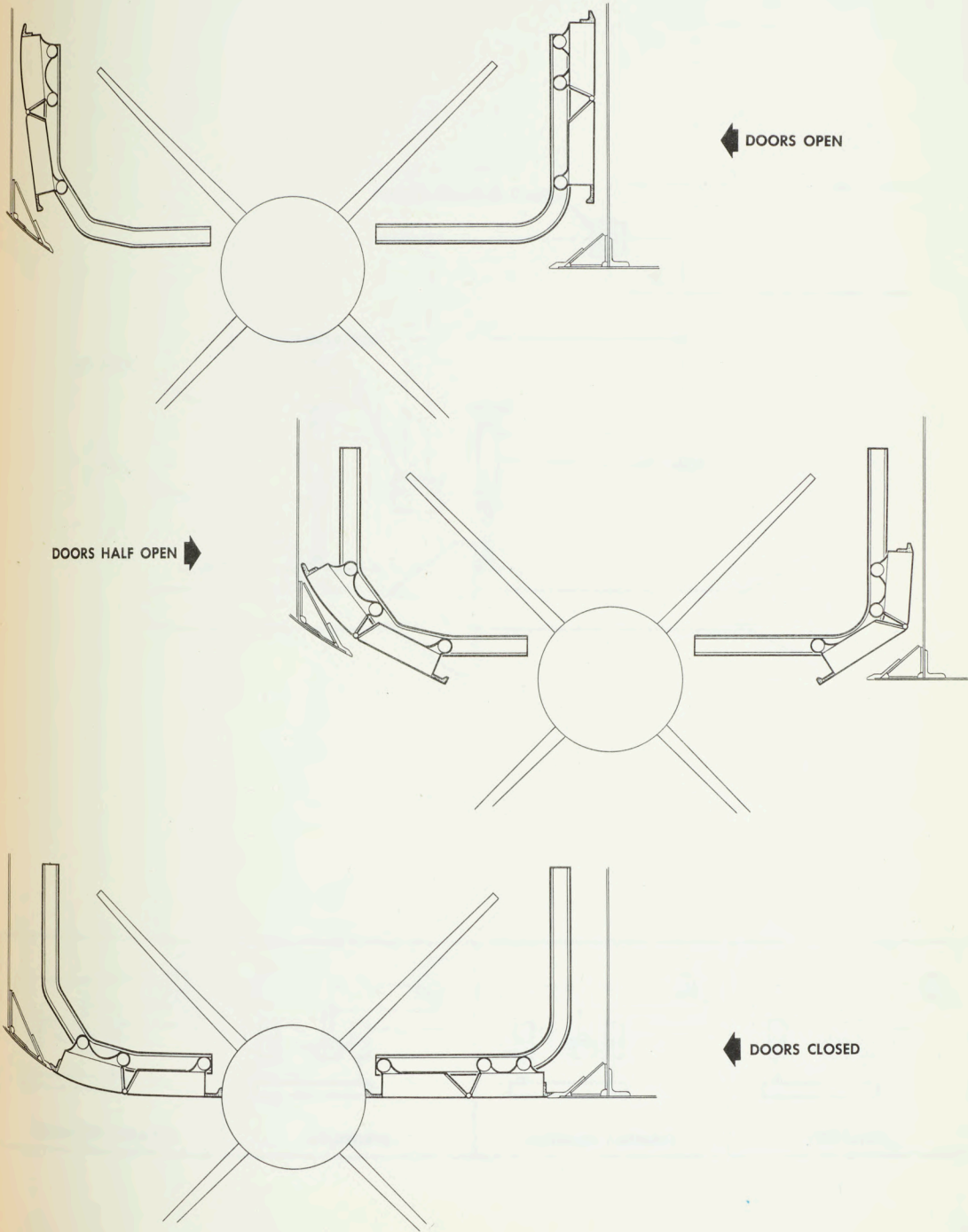

FIG. 6 MISSILE FIN DOORS

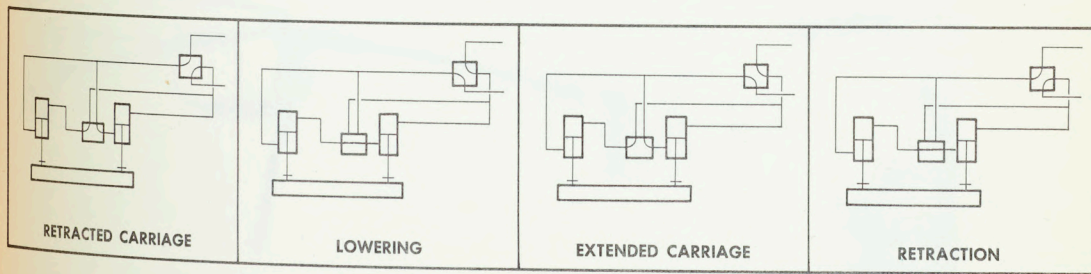
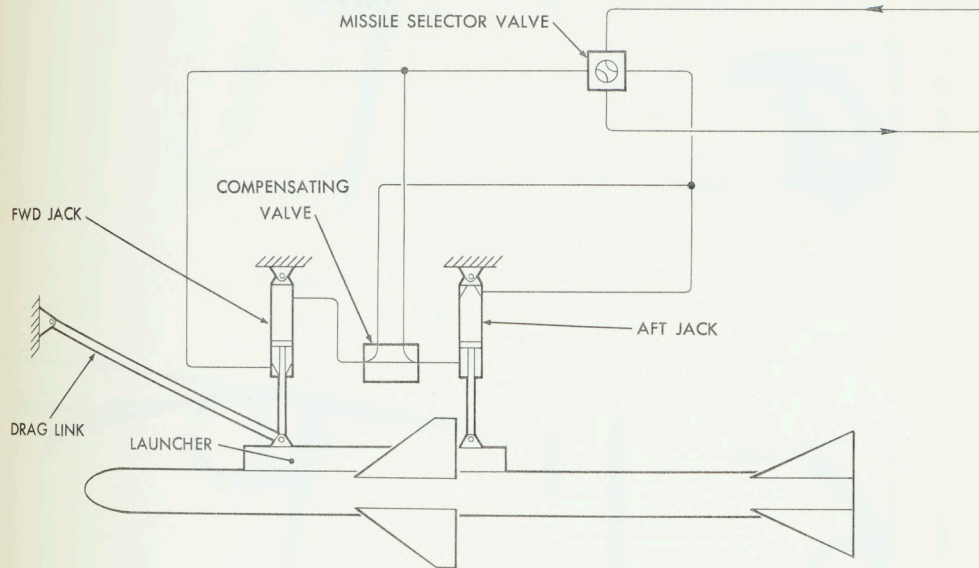
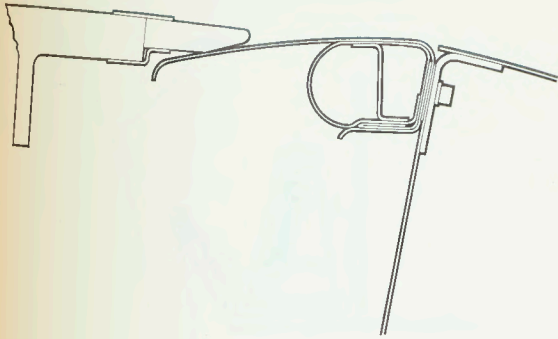

FIG. 7 HYDRAULIC ACTUATION - SINGLE MISSILE



100-100-1



PLUS 4G

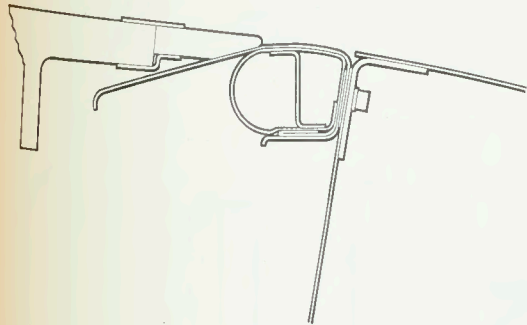

NORMAL

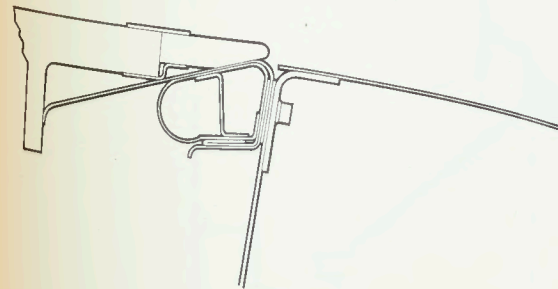

MINUS 1G

PACKAGE SIDE SEAL

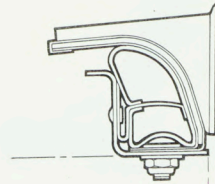

PLUS 4G

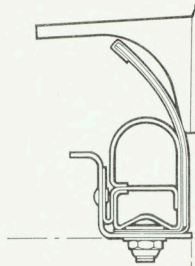

NORMAL

PACKAGE FRONT SEAL

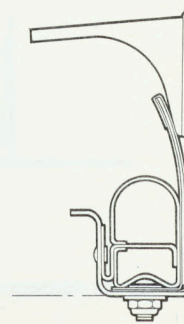

MINUS 1G

FIG. 8 MISSILE PACKAGE SEALS

/8



288-105-1

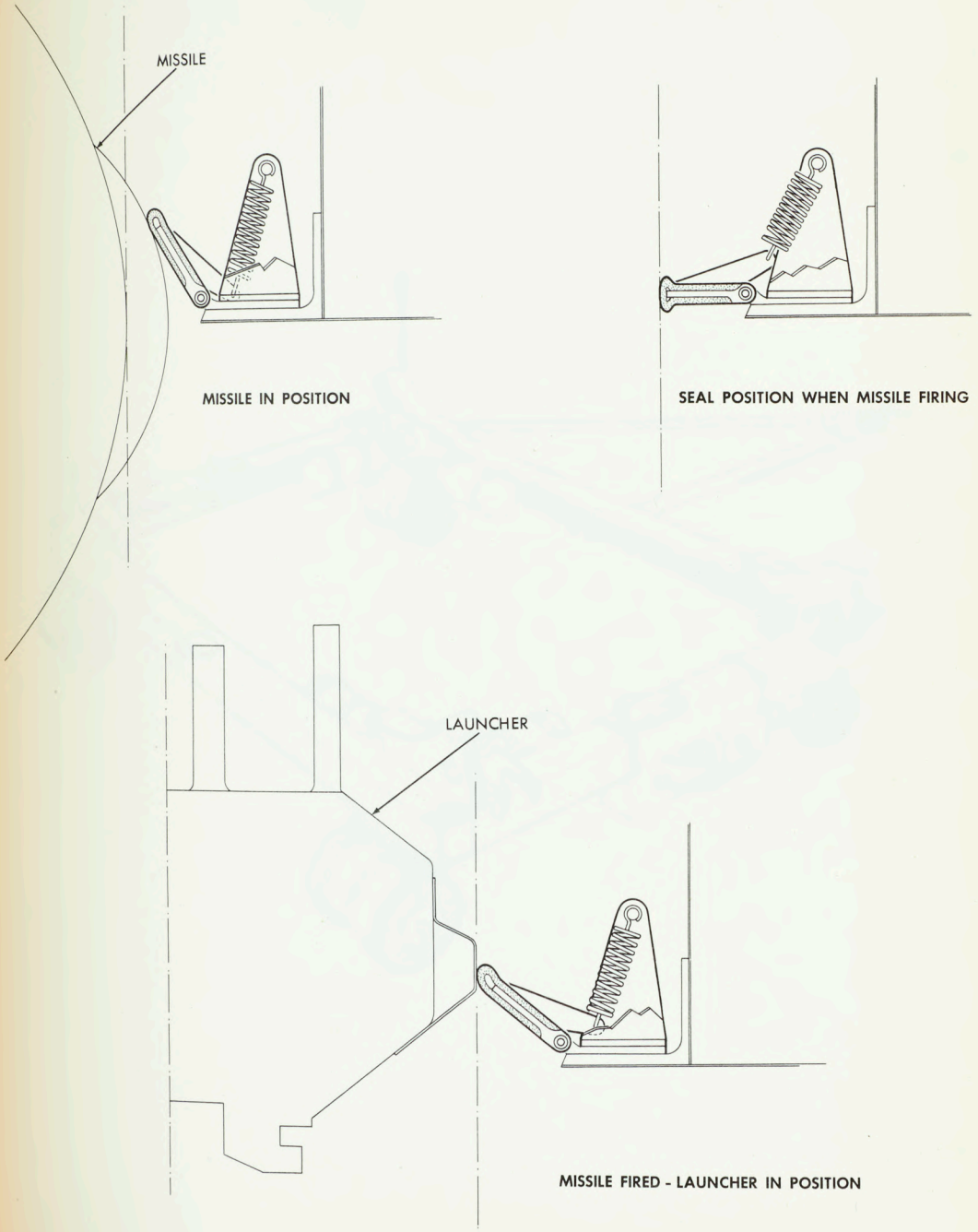

FIG. 9 MISSILE SEALS

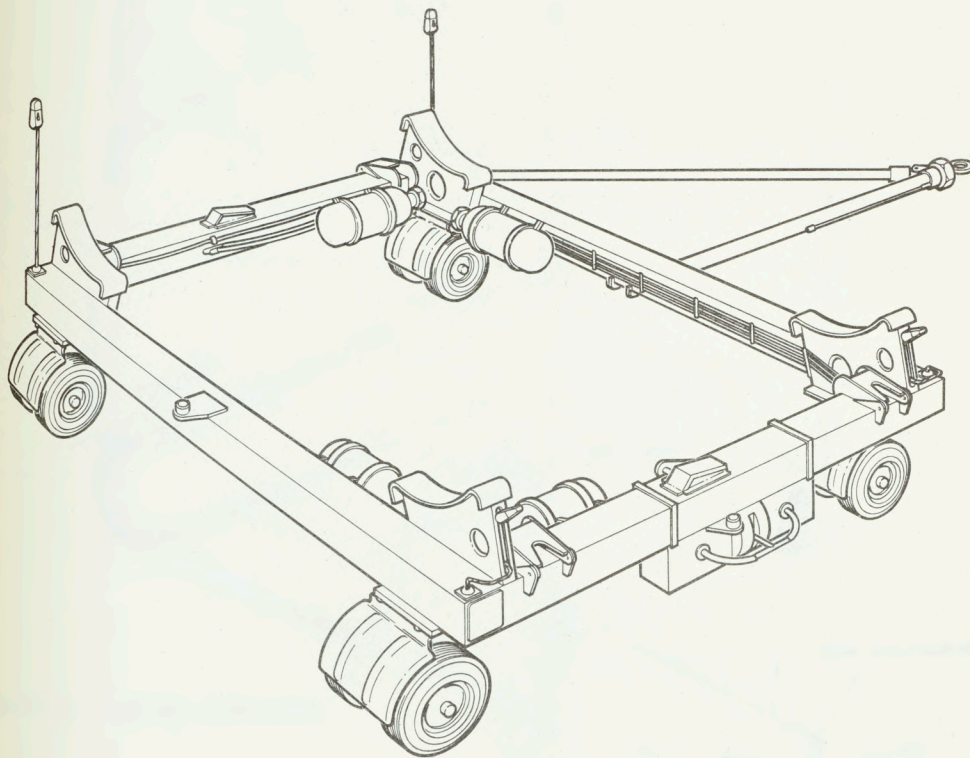

FIG. 10 MISSILE PACK DOLLY

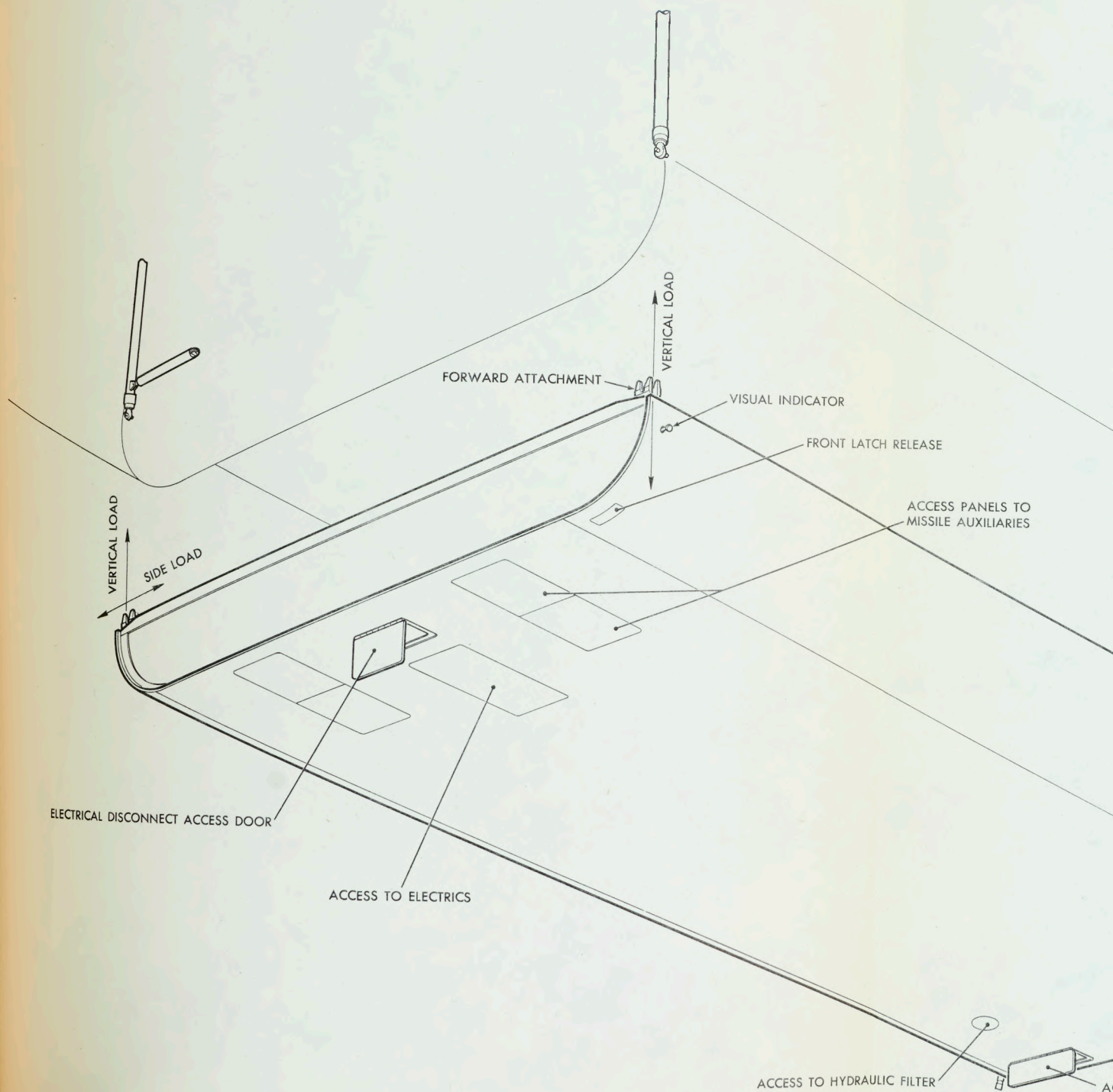
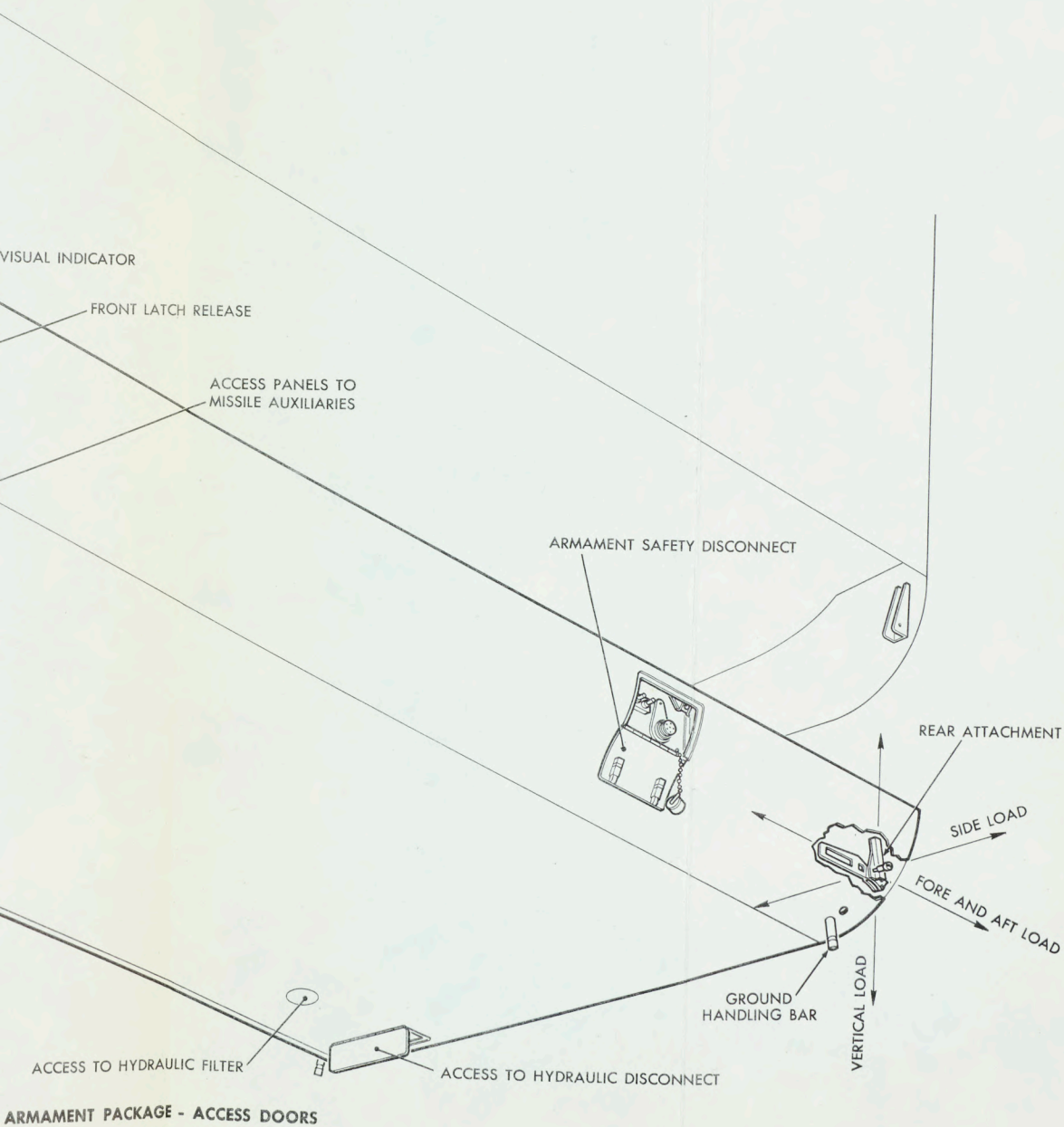
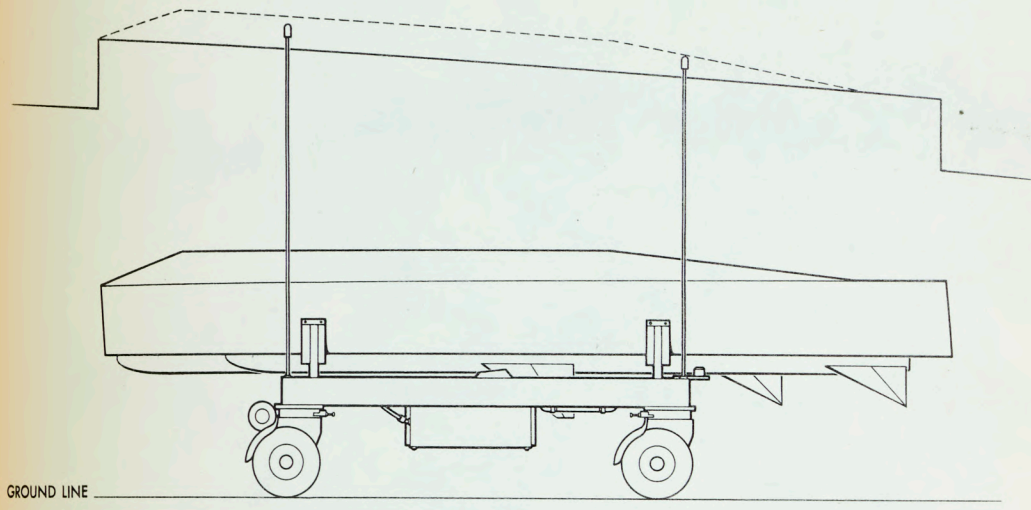

FIG. 11 ARMAMENT PACKAGE - ACCESS DOORS



ARMAMENT PACKAGE - ACCESS DOORS



GROUND LINE

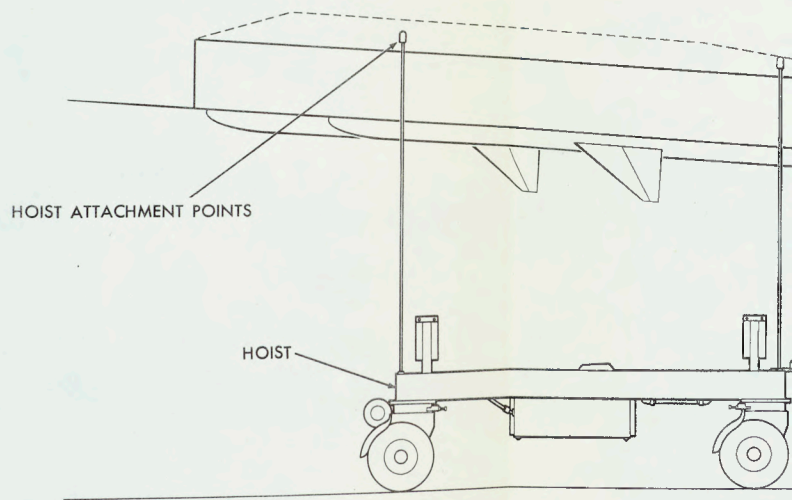
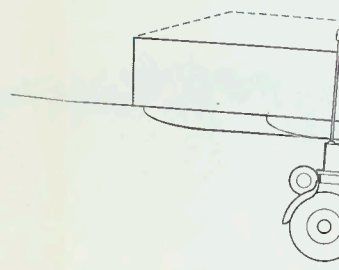

HOIST ATTACHMENT POINTS

HOIST

FIG. 12 ARMAMENT PACKAGE AND HOIST

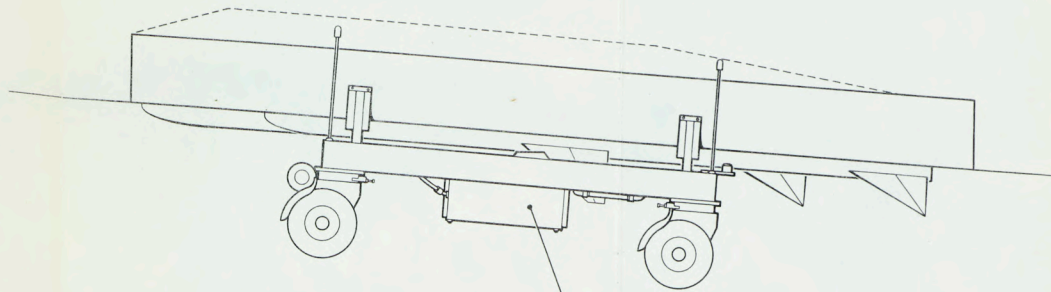

HOIST CONTROL PANEL

GROUND LINE

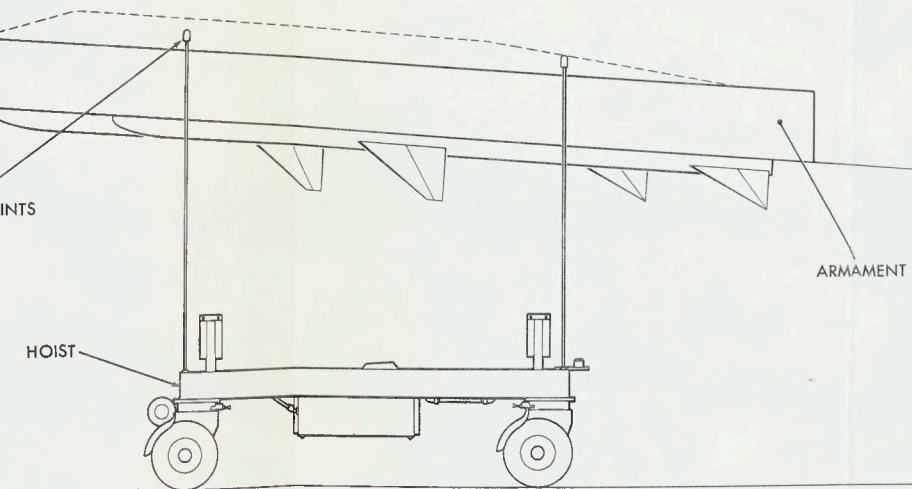

INTS

ARMAMENT PACKAGE

HOIST

GROUND LINE

FIG. 12 ARMAMENT PACKAGE AND HOIST

2681-105-1

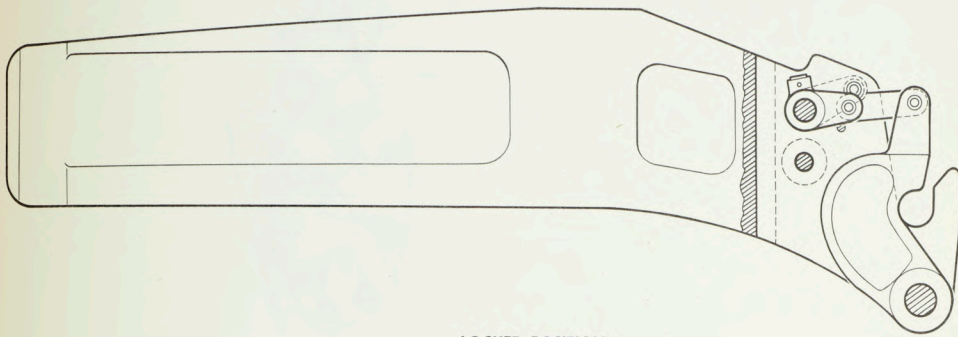

LOCKED POSITION

PUSH AND TURN TO RELEASE PACK

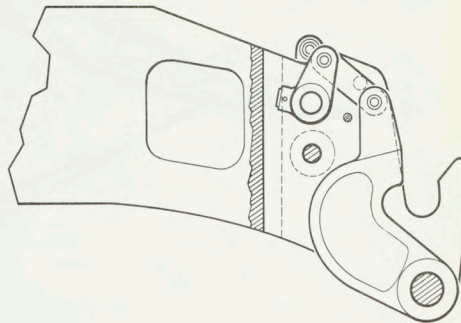
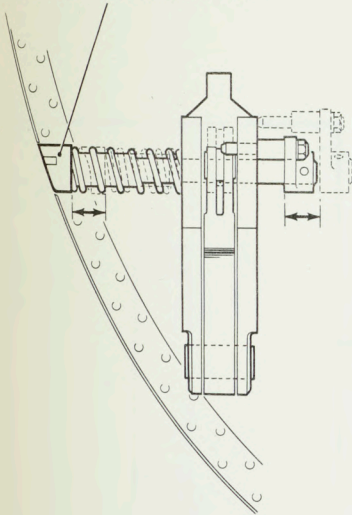

UNLOCKED POSITION

FIG. 13 MISSILE PACK REAR ATTACHMENT

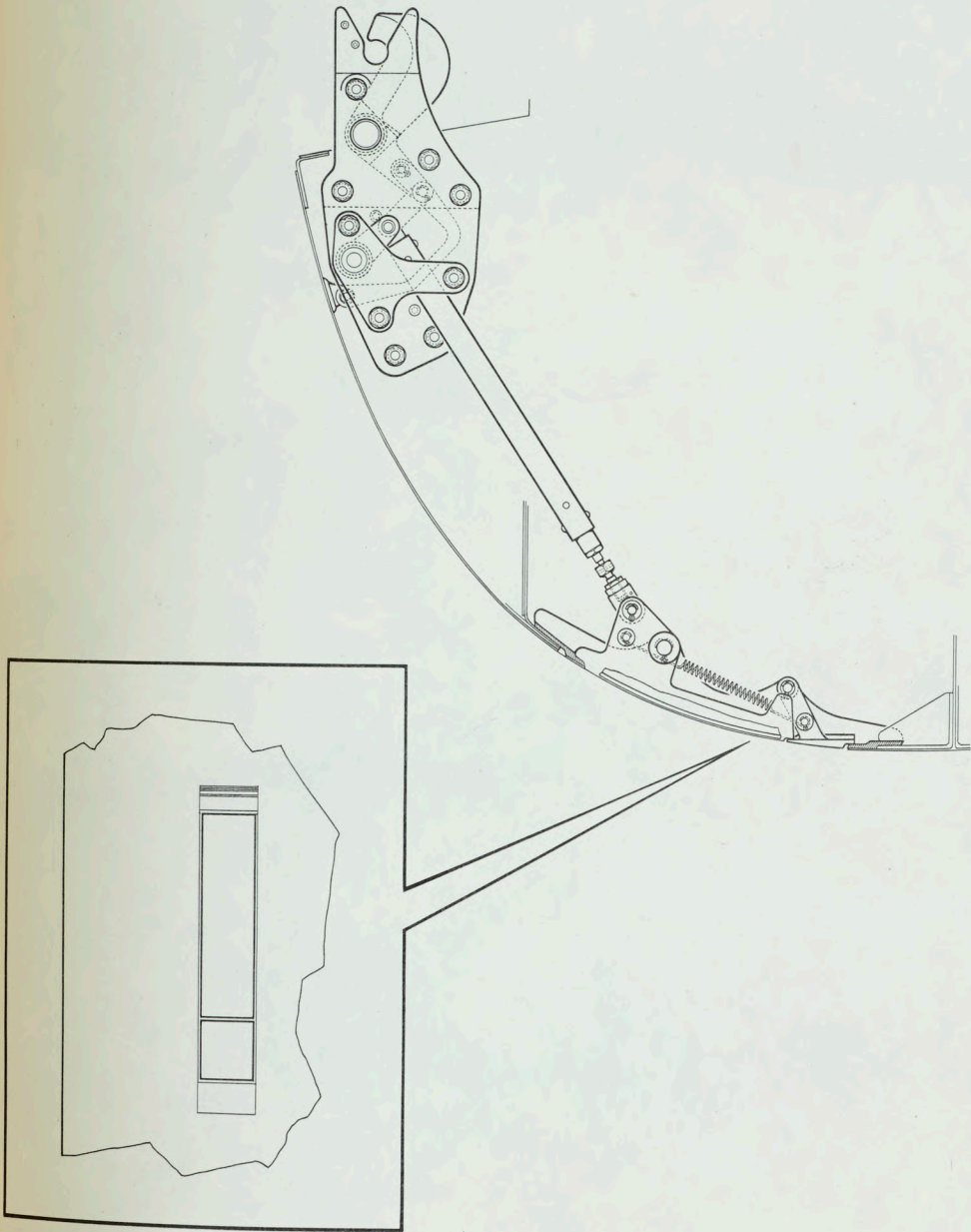

FIG. 14 MISSILE PACK FRONT ATTACHMENT

