

QC  
Avro  
CF105  
Brochure  
H-1 "A"

**CONFIDENTIAL**

 *AVRO AIRCRAFT LIMITED*

CF105 43

**BROCHURE H-1 "A"**

FLYING CONTROL HYDRAULIC SYSTEM

COPY No. 2

**CONFIDENTIAL**

**UNCLASSIFIED**

NRC - CISTI  
J. H. PARKIN  
BRANCH

JUN 8 1995

ANNEXE  
J. H. PARKIN  
CNRC - ICIST

UNCLASSIFIED



AVRO AIRCRAFT LIMITED  
MALTON ONTARIO

Classification cancelled/changed to.....  
by authority of..... (date).....  
Signature *B. McDonald* Rank *PL*

BROCHURE H - 1, A REVISION

DESCRIPTION OF

FLYING CONTROLS HYDRAULIC SYSTEMS

FOR

CF 105

SUPERSONIC ALL WEATHER FIGHTER

CONSISTS OF 24 PAGES

AND 19 ILLUSTRATIONS

UNCLASSIFIED

COMPILED BY *L.H. Treleman*

DATE *Feb. 7, 1956*

CHECKED BY *K. Korzak*

DATE *Feb. 10, 1956*

APPROVED BY *[Signature]*

DATE *Feb 10 / 56*

RELEASED BY *[Signature]*

DATE *FEB 10 / 56*



CONTENTS

<u>DESCRIPTION</u>	<u>SECTION</u>
INTRODUCTION .....	1
DESIGN OBJECTIVES .....	2
DESCRIPTION OF SYSTEM .....	3
DESCRIPTION OF COMPONENTS .....	4
GROUND SERVICING .....	5
EQUIPMENT LIST .....	APPENDIX I



ILLUSTRATIONS

<u>DESCRIPTION</u>	<u>FIGURE</u>
DIAGRAMMATIC .....	1.0
SCHEMATIC .....	1.1
SIMPLIFIED SCHEMATIC .....	1.2
SCHEMATIC - G.S. Rig. ....	1.3
SCHEMATIC - Hand Pump .....	1.4
COMPENSATOR .....	2.0
COMPENSATOR FUNCTIONING .....	2.1
VICKERS PUMP .....	2.2
VICKERS PUMP PERFORMANCE GRAPH .....	2.3
PRESSURE CONTROL VALVE .....	2.4
FILTER - 7 GPM .....	2.5
FILTER - 40 GPM .....	2.6
ACCUMULATOR (Self-Displacing) & GRAPH .....	2.7
TYPICAL FLARELESS CONNECTIONS .....	2.8
COUPLING - EXPANSION .....	2.9
HEAT EXCHANGER (Oil to Air) .....	2.10
HEAT EXCHANGER (Oil to Fuel) .....	2.11
SWITCH PRESSURE .....	2.12
VISCOSITY GRAPH .....	3.0



CONFIDENTIAL  
UNCLASSIFIED

## 1. INTRODUCTION

### 1.1 FLYING CONTROL REQUIREMENTS

The CF-105 aircraft is to be equipped with a fully powered flying control system. This is considered to be the only practical answer to the high surface loads resulting from stability and controllability requirements.

With fully powered controls, the power required to operate the surfaces is completely derived from the engines; the pilot's effort is only that required to overcome the operating loads of the surface control actuator valves, the control linkage friction, and the forces of the "artificial feel systems." The control system may be described as irreversible, and thus there is no feed back of aerodynamic forces to the pilot, hence there is no "natural feel" of speed or normal acceleration of the aircraft.

### 1.2 SYSTEM CONSIDERATIONS

Hydraulic means of transmitting power to the control surface actuators has been chosen as the most suitable and a system pressure of 4000 psi has been selected in order to meet the high response requirements and actuator size limitations as imposed by the aircraft performance and configuration. To achieve a degree of reliability comparable to the highly developed mechanical systems used in the past, the powered control system is duplicated and confined to the exclusive operation of the ailerons, elevators and rudder. The duplication covers input power to the pumping system, the pumps, the hydraulic circuits and the rams of each surface actuator, and is so arranged that adequate flying control power is available in the event of the loss of one engine or one hydraulic system.

### 1.3 SPECIAL DESIGN FEATURES

In the detail design of the hydraulic circuits several innovations have been introduced to ensure proper functioning of the system, with a minimum of maintenance, during operation under the most adverse environmental conditions. Some of these innovations are noted below.

#### 1.3.1 AIR-LESS CIRCUIT

The principle of an "air-less circuit" has been adopted, i.e. a circuit in which the air inclusion is kept to a minimum. In lieu of the usual reservoirs, compensators



UNCLASSIFIED

1.4 SELECTION OF LINE SIZES (Cont'd)

It was considered impractical to size the lines for full flow and control effectivity at  $-65^{\circ}\text{F}$  and pay the weight and space penalties involved, since fluid cooling is necessary after a few minutes of operation to keep the system temperature below  $250^{\circ}\text{F}$ .

1.5 PROCEDURE FOR DISCUSSION OF THE SYSTEM

In this brochure the Flying Control Hydraulic System is discussed in more detail under the following headings:

2. Design Objectives
3. Description of the System
4. Description of the Main Components
5. Ground Servicing

APPENDIX I Equipment List

NOTE: Information on the Flying Control Actuators and Servos is given in Brochure FC-1 entitled: "DESCRIPTION OF CF-105 FLYING CONTROL SYSTEM".



UNCONFIDENTIAL

#### 1.3.1 AIR-LESS CIRCUIT (Continued)

are used, in which stored fluid is kept constantly under pressure (on the ground as well as in flight) and in which there is no direct contact of the fluid with air.

#### 1.3.2 HIGH FLUID TEMPERATURE

Drag considerations dictate the desirability of using the fuel supply as a heat sink for dissipating heat generated by the hydraulic systems. This is precluded under low fuel consumption conditions by fuel temperature limitations at engine inlets and it is therefore necessary to utilize ram air cooling under these conditions. For efficient heat exchange the hydraulic fluid must be operated at as high a temperature as is practicable and 275°F has been established as the upper limit in order to permit the use of standard MIL-O-5606 fluid and developed sealing materials and techniques.

#### 1.3.3 LINE FITTINGS

To provide greater line resistance to fatigue, MS-type flareless fittings, up-rated to 4000 psi working pressure, have been used in preference to the AN flared type. This feature parallels mandatory requirements on all new designs in the USAF and USN and therefore contributes to standardization. (See Fig. 2.8)

#### 1.3.4 FLEXIBLE CONNECTIONS

To avoid problems normally associated with the use of flexible hoses and, in particular, those associated with the high operating temperatures and pressures of this system, flexing steel lines have been used extensively wherever relative motion has to be catered for.

#### 1.4 SELECTION OF LINE SIZES

The line sizes selected for the hydraulic circuits are based on full flow and full control effectivity with a fluid temperature of 0°F.

This operating condition has been chosen as a satisfactory compromise between the system operational characteristics and weight and space-saving considerations.



### 3. DESCRIPTION OF SYSTEM

#### 3.1 SIMPLIFIED SCHEMATIC

Fig. 1.2 shows a simplified schematic of one of the flying control hydraulic systems. The primary flow path is indicated by heavy lines, the solid portion representing the pressure side and dotted portion representing the return side of the closed circuit. Secondary paths are indicated by thin lines and the ground power unit is shown in phantom lines.

##### 3.1.1 PRIMARY FLOW PATH

Variable delivery pumps supply filtered hydraulic fluid to the flying control valves and actuators. Returning fluid passes through a heat exchanger to a compensator, and from there enters the pump. The system is of an "airless" type, with the compensator fulfilling the function of a pressurised reservoir.

##### 3.1.2 SECONDARY FLOW PATHS

The two principle secondary flow paths as shown in Fig. 1.2 are as follows:

- (1) The path through the pressure relief valve protects the system from excessive rises in pressure.
- (2) The path through the pressure reducing valve supplies standby pressure to the compensator in case of failure of the normal pressure supply from the Utility System.

#### 3.2 FILTRATION

All pressure fluid flowing to the flying control actuators is filtered in the 40 (US) GPM 10 micron filter. The aileron and rudder actuators being remote from this filter are provided with further protection for their valves by filters which are fitted close to the actuators. All return fluid passes through a filter mounted on the compensator inlet. (See Fig. 2.0).



### 3.3 TEMPERATURE CONTROL

The pump inlet temperature is maintained below 225°F by the use of a heat exchanger in the circuit upstream of the compensator. Energy losses in the hydraulic circuit, (principally in the pumps and control valves) are transferred, in part, to the hydraulic fluid resulting in a rise in temperature.

The maximum fluid temperature, at the inlet to the heat exchanger, will be +250°F, but localized heating up to +275°F may occur. Under these conditions the outlet temperature will not exceed -225°F. These operation conditions have been taken into consideration in the design of units, seals and in selecting MIL-O-5606 as the hydraulic fluid.

### 3.4 GROUND SERVICE CONNECTIONS

Two ground service connections are provided, one on the pressure side and the other on the return side of the system. This permits the system to be operated by an external source of power (See Fig. 1.3) without operating the pump or the compensator. The low pressure service connection is also used as a filling point for the system. A filter in the return line of the main flow path protects the pumps from any foreign matter which may be introduced when filling the system.



#### 4. DESCRIPTION OF MAIN COMPONENTS

##### 4.1 COMPENSATOR (See Figs. 2.0 and 2.1)

###### 4.1.1 PURPOSE

The compensator is a variable volume, air-less pressure vessel, designed to keep the pump inlet under pressure at all times. It compensates for volumetric changes in the Flying Control Hydraulic System due to thermal expansion and leakage. It also serves as an air separator. The low pressure filter on the inlet of the compensator filters return fluid before it reaches the main compensator chamber.

###### 4.1.2 PHYSICAL DESCRIPTION (See Fig. 2.0)

The compensator consists of a large bore cylinder, of 475 cu. in. capacity with a coaxial small bore cylinder rigidly attached. A large diameter piston with a hollow stem allows the main cylinder volume above the piston to be pressurized by system reduced pressures which are imposed on the hollow stem area in the small cylinder.

###### 4.1.3 PRESSURIZATION

There are two pressure connections on the small cylinder arranged so that either one will function in the event of failure of the other. Reduced pressure at 1500 to 1600 psi, from the Utility System Pressure Control valve, provides the normal means of pressurizing the small cylinder through the central stand pipe. In the bottom of the chamber is a floating piston which is pressurized at 1250 psi from the Flying Controls Hydraulic System Pressure Control Valve. On failure of the normal pressure source, the alternative pressure forces the floating piston against the end of the hollow stem to maintain pressurization in the low pressure chamber. (The stand pipe maintains the separation between the systems).



#### 4.1.4 RELIEF VALVE

A relief valve, designed to relieve at 160 psi, is fitted in the dome at the top of the main chamber. Should this valve open, any air trapped in the dome will be discharged prior to discharge of fluid.

#### 4.1.5 BLEED VALVE

A manually operated bleed valve is provided in the low pressure end of the compensator. In addition to providing an air-bleed for servicing, this valve also enables surplus fluid to be drawn off if the compensator is over-full.

#### 4.1.6 FUNCTIONING OF COMPENSATOR (See Fig. 2.1)

##### 4.1.6.1 VOLUME OF SYSTEM DECREASING

As the hydraulic system cools down, its total volume decreases, reducing the system return pressure acting on the top of the piston. (See detail (b) Fig. 2.1). When the pressure falls to the point where the hydraulic force plus the seal friction is insufficient to balance the 1500 psi pressurization source, the piston will rise to re-establish pressure equilibrium.

##### 4.1.6.2 VOLUME OF SYSTEM INCREASING (See detail (c) of Fig. 2.1)

When the volume of the system increases, the pressure in the head of the compensator increases until it is sufficient to overcome the hydraulic force on the high pressure piston area plus seal friction. The piston then moves down, discharging fluid from the high pressure chamber at 1600 psi, through the relief valve, until a pressure balance is re-established.

##### 4.1.6.3 FAILURE OF NORMAL PRESSURIZATION (Between reducing valve and compensator) (See detail (d) in Fig. 2.1)

When the normal (utility system) fluid pressure falls to a value less than 1250 psi the stand-by system pressure moves the floating piston upwards until it contacts the rim of the hollow piston rod, and thus restores return



#### 4.1.6.3 FAILURE OF NORMAL PRESSURIZATION (Continued)

line pressurization. Due to higher seal friction and the reduced effective area (bore area minus the central stem area) the effective pressurization in top chamber in this stand-by condition is reduced to approximately 75 psi. As the system volume increases, the pressure on the stand-by system increases to 1800 psi before fluid is released through the relief valve.

#### 4.1.6.4 FAILURE OF NORMAL PRESSURIZATION (With line from reducing valve to compensator intact) (See detail (e) of Fig. 2.1)

Pressure will be transmitted to the low pressure chamber, from the stand-by system, through the column of fluid trapped on the normal high pressure supply side of the smaller piston.

If the return side increases and the resulting pressure rise in the lower cylinder exceeds 1600 psi, the trapped fluid will be discharged through the utility relief valve permitting the floating piston to contact the hollow piston stem. The compensator will then operate in the manner described in paragraph 4.1.6.6 above.

#### 4.1.7

#### COMPENSATOR SERVICING

Providing the system is filled correctly initially and no leakage occurs, the compensator will be completely full only if the maximum system temperature is reached. For every mean fluid temperature within the design temperature range there is a corresponding piston position that indicates a "full" system. A constant reading piston position indicator, calibrated in degrees of temperature, is fitted to each compensator to indicate the volume of the contained fluid. Comparison of the actual system temperature, determined within acceptable limits from a thermometer in an insulated mounting on a hydraulic component in the aircraft, with the piston indicator reading gives the required information on system volume.



## 4.2 VARIABLE DELIVERY PUMP (See Fig. 2.2 & 2.3)

### 4.2.1 PUMP DRIVE

Each flying control hydraulic system incorporates two identical pumps, one of which is driven through a geared drive from the L.H. main engine, and the other from the R.H. main engine. These pumps are also identical with those used in the Utility Hydraulic System.

### 4.2.2 PUMP INLET PRESSURE

The inlet pressure to each pump is controlled at a nominal value of 90 psi by the compensator. The pumps will operate satisfactorily with any inlet pressure from 30 to 130 psi, and will withstand intermittent operation with inlet pressures down to 2 psi absolute.

### 4.2.3 DELIVERY RATE

The pumps are of the variable displacement type with integral outlet pressure sensing unit which varies the delivery rate to meet the system demands as reflected in pressure drop. This unit is set to maintain a nominal 4000 psi outlet pressure. Available delivery rate varies directly as the engine speed, reaching a maximum of approximately 20 (US) GPM per pump at 3250 RPM (equivalent to full engine RPM). The pumps will withstand an overspeed up to 3900 RPM in the event of engine malfunction.

### 4.2.4 PUMP INLET CONNECTION

The system return is connected to the pump through a quick-disconnect self-sealing coupling. This prevents loss of system fluid, and minimises the possibility of air inclusion in the system when the pump is removed for servicing.

### 4.2.5 PUMP DELIVERY MANIFOLD (See Fig. 2.1)

The outputs from the two pumps in each system are united in a manifold which incorporates a check valve in each inlet. In the event of one pump failure, the check valve in the respective manifold inlet will prevent the reverse flow of fluid through the inoperative pump. The check valves also prevent reverse flow through both pumps during operation of the ground servicing unit.



## 2. DESIGN OBJECTIVES

- 2.1 To provide an irreversible hydraulic system to move the control surfaces individually or in combination to meet the following maximum rate and hinge moment requirements at fluid temperatures down to 0°F:
- (a) Elevators - 60,000 lb.-ft. @ 40°/sec.
  - (b) Ailerons - 25,000 lb.-ft. @ 35°/sec.
  - (c) Rudder - 12,000 lb.-ft. @ 40°/sec.
- 2.2 To provide adequate control power for flight (with limited manoeuvrability) under the following conditions:
- (a) Fluid temperature as low as minus 20°F.
  - (b) Asymmetric flight due to single engine operation.
  - (c) Failure of one of the duplicated Flying Controls Hydraulic Systems.
- 2.3 To restrict system operating temperatures to a maximum of 250°F (with temperatures up to 275°F in local sections of the circuit) by the use of heat exchangers to permit the use of currently available sealing techniques and MIL-O-5606 hydraulic fluid.
- 2.4 To provide a high degree of system reliability through the use of pump inlet pressurization to overcome cavitation tendencies at low temperature and high altitude.
- 2.5 To provide a system which will meet the requirements of document AIR-7-4, which in turn calls for the design requirements of CAP 479, "Manual of Aircraft Design Requirements for the Royal Canadian Air Force" and ARDCM 80-1, "Handbook of Instructions for Aircraft Designers".



#### 4.2.6 PUMP CASE DRAIN

A pump case drain line from each pump is connected to the system return line upstream of the low pressure filter on the compensator. This drain line provides for disposal of the internal leakage from the pump, thus providing the necessary lubrication and cooling of the pump mechanism. This port also serves for case filling after pump installation, as it is located at the highest point in the casing to prevent entrapment of air.

A check valve is incorporated in the case drain line to protect the pump from possible surges in the system return line and also to prevent loss of fluid from the system when the pump is removed for maintenance.

### 4.3 FILTERS

#### 4.3.1 FILTER - BOWL TYPE, HIGH PRESSURE, 40 (US) GPM (See Fig. 2.6)

##### 4.3.1.1 PURPOSE IN SYSTEM

The high pressure 40 (US) GPM filters are located in the pressure side of the system downstream of the pumps and ground servicing coupling. These filters protect the flying control valves and actuators and the automatic flight command (parallel) servos. They are the master high pressure filters and are designed to provide filtration down to 10 micron size.

##### 4.3.1.2 SELF-SEALING PROVISIONS

The filter bowl and element can be removed without completely depressurising the system, provided pressure on the high pressure side is reduced to normal return pressure (approx. 90 psi). When the bowl is being removed, internal valves in the filter head move to positions which prevent loss of any appreciable amount of fluid and consequent entry of air into the system lines.



#### 4.3.1.3 RELIEF VALVE OPERATION

The relief valve is set for  $50 \pm 5$  psi cracking pressure differential across the element. Should the pressure drop across the filter element exceed this value due to excessive clogging of the filter element, flow will bypass the filter element.

In normal conditions, i.e. when the clogging does not exceed a certain allowable value (equivalent to blocking off 25% of the filter element area), the filter is designed to work without by-passing in the following conditions:

- (1) at rated flow at all temperatures above  $0^{\circ}\text{F}$ ,
- (2) at 50% of the rated flow at all temperatures above  $-20^{\circ}\text{F}$ ,
- (3) at 7.5% of rated flow at all temperatures above  $-65^{\circ}\text{F}$ .

#### 4.3.1.4 FILTER ELEMENT

The 40 GPM filter elements used in the flying controls system filters are of the cleanable, re-usable type.

#### 4.3.2 FILTER - BOWL TYPE, LOW PRESSURE, 40 (US) GPM (See Fig. 2.6)

This filter is installed in the return side of the system, mainly to protect the pumps. It is placed upstream of the compensator to assure a positive pressure at the pump inlet. It is mounted on the inlet of the compensator to filter particles of 10 microns and larger from the fluid returning from relief valves, case drain from pumps, actuators, and ground servicing connection, thus protecting the pumps and the compensator. The low pressure filters are equipped with self-sealing valves and relief valves to provide the same operating and servicing facilities as specified for the high pressure filters in paragraph 4.3.1.2 and 4.3.1.3 above. This filter will use the same element of 40 (US) GPM capacity developed for the high pressure filter.



#### 4.3.3 FILTER - SECONDARY HIGH PRESSURE (See Fig. 2.5)

##### 4.3.3.1 PURPOSE IN SYSTEM

Due to the long lines separating the main 40 (US) GPM high pressure filter from the rudder and aileron actuators, additional filtration protection is provided near these units, by means of individual filter assemblies of 4 and 7 (US) GPM nominal capacity respectively. After the initial cleansing of the system, it is anticipated that these filters will require very infrequent service attention as the main filter, more readily accessible, will retain most of the contaminants.

##### 4.3.3.2 FILTER ELEMENT

The filter elements are made from the same material as the main 40 GPM high pressure filter elements and are designed to provide protection from particles down to 10 microns. The elements will be re-usable after cleaning.

##### 4.3.3.3 BY-PASS RELIEF VALVE

Each filter assembly incorporates a by-pass relief valve so that undue restriction of flow through the filter element will result in flow being by-passed around the element. The relief valve is set to open when the pressure drop across the element exceeds  $50 \pm 5$  psi.

#### 4.4 PRESSURE CONTROL VALVE (See Fig. 2.4)

The three valves described below have been combined into one unit to simplify piping, conserve space and reduce the number of mounting points.

##### 4.4.1 SYSTEM PRESSURE RELIEF VALVE

The pressure relief valve is set to relieve at a maximum pressure differential of 4225 psi which, with the normal pressure of 90 psi in the return side of the system, gives an actual pressure of 4315 psi. The valve provides full flow relief at a pressure of 4740 psi.



#### 4.4.2 PRESSURE REDUCING VALVE

The pressure reducing valve reduces normal system pressure to a nominal value of 1250 psi for emergency pressurization of the flying controls system compensator. This standby pressure also insures that system negative pressure surges do not affect the compensator.

#### 4.4.3 SERVICE RELIEF VALVE

A service relief valve is provided to permit relief flow of fluid from the high pressure side of the compensator when fluid is forced into the low pressure side.

### 4.5 ACCUMULATOR - 100 CUBIC INCH, SELF DISPLACING (See Fig. 2.7)

#### 4.5.1 PURPOSE IN SYSTEM

##### 4.5.1.1 ASSISTANCE TO PUMP

Whenever the control valve of an actuator is moved off its neutral position there is a demand for high pressure fluid. The accumulator with its nitrogen charge can supply this demand momentarily faster than the pump thus giving quicker control response. The accumulator will be recharged by the pump when the demand has been met. The accumulator will also provide damping for pressure surges and pulsations caused by rapid valve operation.

##### 4.5.1.2 ASSISTANCE TO COMPENSATOR

The self displacing accumulator provides capacity on the return side of the system equivalent to the fluid drawn off the high pressure side. Thus for control movements handled initially by the accumulator, there will be no change in compensator level. The compensator seals would be particularly sensitive to frequent low amplitude oscillations which would occur if the self-displacing accumulator were not used. In the event of utility system failure, the accumulator, (if charged with fluid on the pressure side in excess of 1250 psi) will pressurize the compensator during engine shut-down.



#### 4.5.2 PHYSICAL DESCRIPTION OF ACCUMULATOR (See Fig. 2.7)

The self-displacing accumulator consists essentially of a high pressure cylinder and a low pressure cylinder, fitted end to end with the piston of each cylinder rigidly joined together by a connecting rod passing through the common cylinder end.

The two inner chambers of the accumulator (adjacent to the common cylinder end) contain fluid. In the high pressure cylinder the fluid is maintained under high pressure by the nitrogen charge on the opposite side of the piston. The fluid chamber of the other cylinder is connected into the return-flow side of the hydraulic circuit, the chamber opposite the low pressure cylinder is vented to atmosphere. It can be seen that the total volume of fluid will always be the same; as fluid leaves the high pressure side, the inter-connected pistons move to provide room for the additional volume in the return chamber. The 100 cubic inch in the description is the nitrogen volume of the accumulator with all pressure hydraulic fluid discharged. The fluid volume of the accumulator is 90 cu. in. maximum.

#### 4.6 SWITCH - HYDRAULIC PRESSURE (See Fig. 2.12)

##### 4.6.1 GENERAL DESCRIPTION

The switch body has a hydraulic port at one end and an electrical connection at the other. Inside the case, a pressure-sensitive mechanism actuates a snap-action type electrical switch which has a wide range between snap and reset. A warning light glows in the cockpit when system pressure falls too low and actuates this pressure switch.

##### 4.6.2 PRESSURE SETTINGS

The switch closes the electrical contacts as system pressure falls to 1000 psi and opens them again when system pressure rises to 3000 psi or higher. In normal flight manoeuvres, the light should not go on, even momentarily, unless system malfunction occurs.



#### 4.7 HEAT EXCHANGER

##### 4.7.1 HEAT SOURCE

The high powered pumps and actuators generate large quantities of heat in the hydraulic fluid which is circulating through them. Little heat can be rejected to the surrounding air because of the high ambient temperatures which may be encountered. Therefore, a heat sink is required to keep the fluid temperature from exceeding a temperature of 275°F. The inlet fluid temperature at the pumps must not exceed 225°F, in order that sufficient cooling capacity would be available for the minimum fluid flow case.

##### 4.7.2 HEAT SINKS

The principal heat sink is the oil-to-air heat exchangers which protrude from the underside of the aircraft fuselage under the engines. A secondary heat sink is the oil-to-fuel heat exchanger downstream which transfers the residual heat load into the fuel being drawn into the engines.

##### 4.7.3 OIL-TO-AIR HEAT EXCHANGER

This heat exchanger has a relief valve by-pass which opens at low temperatures allowing the fluid to avoid passing over the cold heat transfer surfaces when the high viscosity of the oil raises the pressure drop above 10 psi differential pressure. For cold starting, the low flow circulation through the main exchanger passages and the high flow circulation through the by-pass passages rapidly heats up the whole exchanger to provide full heat exchange capacity when the system fluid temperature has risen to 275°F at the heat exchanger inlet.

##### 4.7.4 OIL-TO-FUEL HEAT EXCHANGER

The oil-to-fuel heat exchanger serves to carry the extra cooling load that cannot be handled by the primary oil-to-air heat exchanger.

This exchanger has a by-pass relief valve which, for low temperature operation, will permit the main part of the flow to short-circuit the oil-to-fuel heat



#### 4.7.4 OIL-TO-FUEL HEAT EXCHANGER (Continued)

transfer surfaces if the pressure drop through them is in excess of approximately 3 psi.

A special feature of the valve is a thermostatic element which is sensitive to fluid outlet temperature. At max. temperature the by-pass valve closes, forcing the main flow through the heat transfer area. Thus the secondary heat exchanger shares the load with the oil-to-air heat exchanger when the latter is overloaded.

#### 4.8 EXPANSION COUPLINGS

Expansion couplings have been incorporated where necessary on long straight runs in hydraulic lines, to relieve stresses due to structural flexing or thermal expansion or contraction. A system of internal passages and carefully dimensioned pressure areas ensures that each unit is hydraulically balanced in any degree of expansion.

NOTE: For complete information on the internal details and system functioning of the Flying Control Actuators and Servos refer to Brochure FC-1 entitled: "DESCRIPTION OF CF-105 FLYING CONTROL SYSTEM".



## 5 GROUND SERVICING (See Figs. 1.2, 1.3 & 1.4)

### 5.1 REQUIREMENTS - GENERAL

Equipment must be attached to the external disconnect couplings of the aircraft hydraulic systems to perform the following servicing tasks:

1. Filling of the Flying Control and Utility Hydraulic Systems.
2. Refilling the compensators after they have been bled of any entrapped air.
3. Operation of any one of the systems for checkout or trouble shooting without running the engines.

### 5.2 GROUND SERVICING EQUIPMENT REQUIREMENTS

The following 2 units will be required to perform the servicing tasks listed above:

1. A mobile hydraulic power unit, complete with motor driven pump, reservoir, pressure gauges and hose connections to couple up to the aircraft systems. This equipment is to recharge the accumulator and to power each hydraulic system when the engines are shut down. (See Fig. 1.3)
2. A hand pump with hose connections and self-sealing couplings, adapted for temporary support on the aircraft or on the ground servicing unit. This equipment is required for filling the compensators on any of the 3 aircraft systems, and also the compensator on the ground servicing hydraulic power unit. (See Fig. 1.4)

### 5.3 DISCONNECT SELF-SEALING COUPLINGS AND ACCUMULATORS

Due to the fact that most self-sealing couplings cannot be attached or detached while pressure remains on the system, it is necessary to dump all pressure prior to disconnecting. The emergency braking and compensator-pressurizing accumulator of 200 cu. in. capacity, being isolated by a check valve in the pressure control valve, is unaffected when the system pressure is released.



## 5.4 PROTECTION OF THE AIRCRAFT HYDRAULIC SYSTEMS (See Fig. 1.2)

### 5.4.1 FILTERS

To prevent the introduction of foreign material into the hydraulic fluid during connecting and disconnecting of self-sealing couplings, no fluid is permitted to enter the main system components (valves, compensators and pumps) without first passing through the main high pressure or the main low pressure filter. High pressure fluid from the ground servicing unit enters the main line upstream of the pumps and their check valves, and then passes through the main high pressure filter.

### 5.4.2 FILLING CONNECTION LOCATION

To fill the system, fluid is pumped in through the system return self-sealing coupling at the inlet to the filter attached to the compensator, hence the added fluid is filtered before it reaches the compensator. An additional filter upstream of the hand pump (See Fig. 1.4) provides further protection for the aircraft hydraulic systems.

## 5.5 POWERED GROUND SERVICING UNIT (See Fig. 1.3)

The principal components of this unit and their functions are listed below.

### 5.5.1 PUMP

A variable delivery pump of about 20 GPM maximum capacity and capable of maintaining a 4000 psi. system pressure is provided.

This pressure, corresponds to system operating pressure, and is required to fully charge the Utility Hydraulic System accumulator, referred to in Brochure H-2. Manual displacement control is optional.

### 5.5.2 FILTER

Protection for the pump is afforded by a 10 micron return line filter between the return coupling and the pump as foreign material could enter at the disconnect during coupling operations.



### 5.5.3 COMPENSATOR

To maintain air-less operation in the aircraft systems, the ground servicing unit uses an air-less reservoir identical in operation to the ones on the aircraft and with the same air-separation and air bleed provisions. (See Sect. 4.1)

### 5.5.4 RELIEF VALVE WITH MANUAL CONTROL

A relief valve, capable of handling 20 GPM flow at 4750 psi, is provided for system protection. A manual override is incorporated to permit the system pressure to be released after the ground servicing unit power is turned off. (This valve may be combined with the pressure reducing valve in one body similar to the pressure control valves in the aircraft systems.)

### 5.5.5 PRESSURE REDUCING VALVE WITH MANUAL ADJUSTMENT

When the ground servicing unit is connected into an aircraft system, there are two compensators trying to maintain system return pressure. If the pistons are in motion, with seal friction fairly low, the compensator with the slightly higher pressurization will drive the other compensator to the bottom of its stroke. Manual control of the pressure reducing valve on the ground servicing compensator is provided to adjust the level of the aircraft system compensator just prior to disconnecting the ground servicing unit.

### 5.5.6 PRESSURE GAUGES

A pressure gauge, reading up to 5000 psi., is provided on the pressure line. This gauge has an easily read dial and has a fine calibration in the 4000 psi range.

Provided this gauge is calibrated accurately and rechecked periodically, it may also be used to check pump operation in an aircraft system while the engines are run up separately. A smaller pressure gauge will be used in the compensator pressurization line to ensure that the correct reduced pressure is supplied. (See 5.5.5 Pressure Reducing Valve.)



#### 5.5.7 ACCUMULATOR, FLOATING PISTON

This accumulator maintains pressurization of the compensator to provide a constant positive pressure at the inlet port of the pump. If the pump available is not sensitive to low inlet pressures, this accumulator will be eliminated.

#### 5.5.8 VALVE - THERMAL RELIEF

When the isolated accumulator is in the system, overpressure due to a rise in temperature is avoided by having the thermal relief valve crack at a pressure higher than the main system relief valve cracking pressure.

#### 5.5.9 SYSTEM TEMPERATURE CONTROL

A heat exchanger is provided to ensure that system temperature does not exceed the limiting temperature of 250°F during continuous operation of the unit. Also, an indication of system temperature is to be provided at the heat exchanger outlet.

### 5.6 COMPENSATOR FILLING HAND PUMP ASSY. (See Fig. 1.4)

#### 5.6.1 PURPOSE

This equipment enables the hydraulic systems to be filled or replenished without releasing the system return pressure, and reduces the possibility of introducing air or contaminating material into the system being serviced. The use of a self-sealing coupling renders the operation as fool-proof, simple and rapid as possible.

#### 5.6.2 COMPONENTS OF HAND PUMP ASSEMBLY

The following are the principal components of the hand pump assembly and the purposes of each:

##### 5.6.2.1 AIR BLEED VALVE

Since the pump assembly is self-sealing only at the delivery end it must be primed before connecting up to the aircraft system being filled. Once the probe has been inserted into a supply of uncontaminated fluid, all the air will be bled out of the probe, hoses, filter



5.6.2.1 AIR BLEED VALVE - continued

and pump while the coupling end is kept higher than the rest of the assembly.

5.6.2.2 CHECK VALVE

This valve is provided to permit the filling of systems under pressures in the order of 90 psi. It is located as close to the coupling as possible.

5.6.2.3 HAND PUMP

This pump is provided to enable filling of the system against a back pressure of approximately 90 psi, while drawing fluid from a container a short distance from the pump. It has a mounting bracket enabling it to be supported at the edge of an access door in the hydraulic equipment bays.

5.6.2.4 FILTER

A filter with a 10 micron element is required on the inlet side of the hand pump to protect the pump and to ensure that only clean fluid is delivered to the aircraft systems.



## APPENDIX I

UNCLASSIFIED  
CONFIDENTIAL

## EQUIPMENT LIST

DESCRIPTION	QTY.	AVRO PART No.	SPEC.	MANUFACTURER AND PART No. WHERE APPLICABLE
ACCUMULATOR - SELF DISPLACING 100 CU. IN.	2	7-3258-41	E210	BENDIX
CAP. - SEALING 1000 P.S.I.	2	CS-C-139-12	E 232	
CAP. - SEALING 4000 P.S.I.	2	CS-C-138-10	E232	
COMPENSATOR - DUAL PRESSURIZED	2	7-3258-37	E231	H. W. LOUD
COUPLING - EXPANSION 5/8 TUBE SIZE	4	7-3262-14	E385	DOWTY
COUPLING - EXPANSION 1/2 TUBE SIZE	4	7-3262-16	E385	DOWTY
COUPLING HALF - HYD. SELF SEALING 1000 P.S.I.	2	CS-C-149-12	E232	
COUPLING HALF - HYD. SELF SEALING 4000 P.S.I.	2	CS-C-147-10	E232	
COUPLING HALF - PUMP SUCTION	4	7-3258-45	E349	EASTERN A/C
COUPLING HALF - PUMP SUCTION	4	7-3258-47	E349	EASTERN A/C
ELEMENT - 40 G.P.M. 4000 P.S.I.	4	7-3258-25	E399	AIRCRAFT POROUS MEDIA
ELEMENT - 7 G.P.M.	4	7-3264-14	E330	AIRCRAFT POROUS MEDIA
ELEMENT - 4 G.P.M.	2	7-3283-9	E330	AIRCRAFT POROUS MEDIA
FILTER BODY - H/P 40 G.P.M. MULTI OUTLET	2	7-3258-43	E249	PARMATIC
FILTER BODY 7 G.P.M. L/H (AILERON) R/H	1 1	7-3264-65 66	E249	AVRO AIRCRAFT
FILTER BODY 7 G.P.M. L/H (AILERON) R/H	1 1	7-3264-67 68	E249	AVRO AIRCRAFT
FILTER BODY 4 G.P.M. (RUDDER)	1	7-3283-11	E249	AVRO AIRCRAFT
GAUGE - BLEED SIGHT DRAIN	2	CS-G-108	E247	PRENCO
GAUGE - REDUCED PRESS.	2	7-3258-29	E432	
HEAT EXCH. HYD. FLUID TO FUEL C/W BY-PASS VALVES	2	7-3256-5	E389	
HEAT EXCH. OIL/AIR	2	7-3256-3	E388	

23

H-1



UNCLASSIFIED

24

DESCRIPTION	QTY.	AVRO PART No.	SPEC.	MANUFACTURER AND PART No. WHERE APPLICABLE
MANIFOLD - H/P PUMP DELIVERY	2	7-3258-16	E340	AVIATION ELECTRIC
PUMP-VARIABLE DELIVERY	4	7-3258-13	E284	VICKERS
SWITCH - PRESSURE WARNING TYPE I	2	7-3258-35	E303	PARMATIC
VALVE - AIR CHARGING & GAUGE	2	CS-V-104	E306	KENYON
VALVE - CHECK	2	CS-V-103-10	E208	PARKER
VALVE - CHECK	4	CS-V-107-6		
VALVE - PRESSURE CONTROL	2	7-3258-14	E307	VINSON
VALVE - SUMP DRAIN	1	7-3258-24	E391	AUTO VALVE

1-1  
H

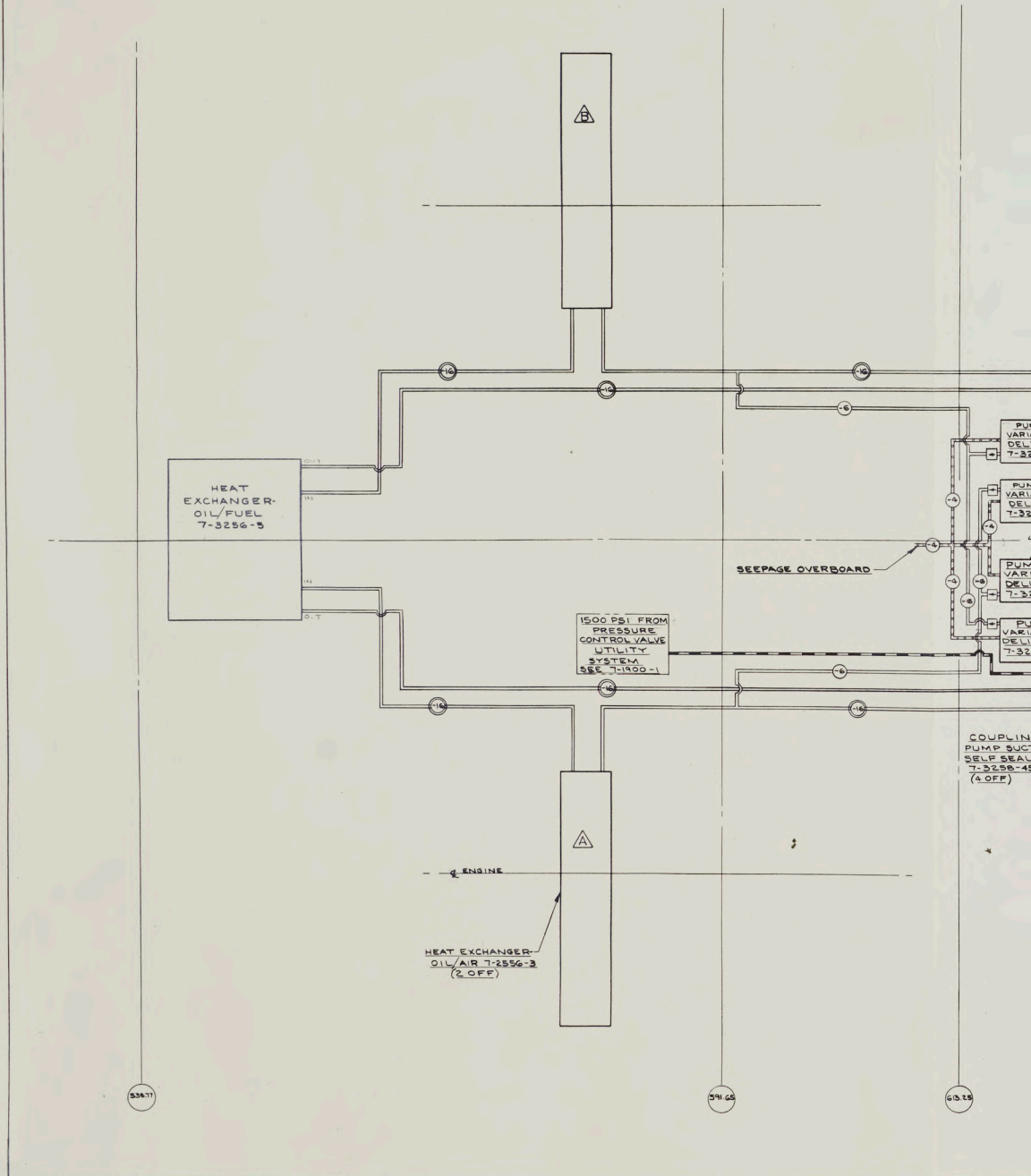

**LEGEND**

- SYSTEM PRESSURE (4000 PSI)
- SYSTEM RETURN (90 PSI)
- REDUCED PRESSURE (1500 PSI)
- REDUCED PRESSURE (1250 PSI)
- DRAIN LINE
- ⊕ HIGH PRESSURE AIR (4,000 PSI)
- ⊖ INDICATES LINE SIZE IN 1/16 IN.
- △ INDICATES SYSTEM 'A'

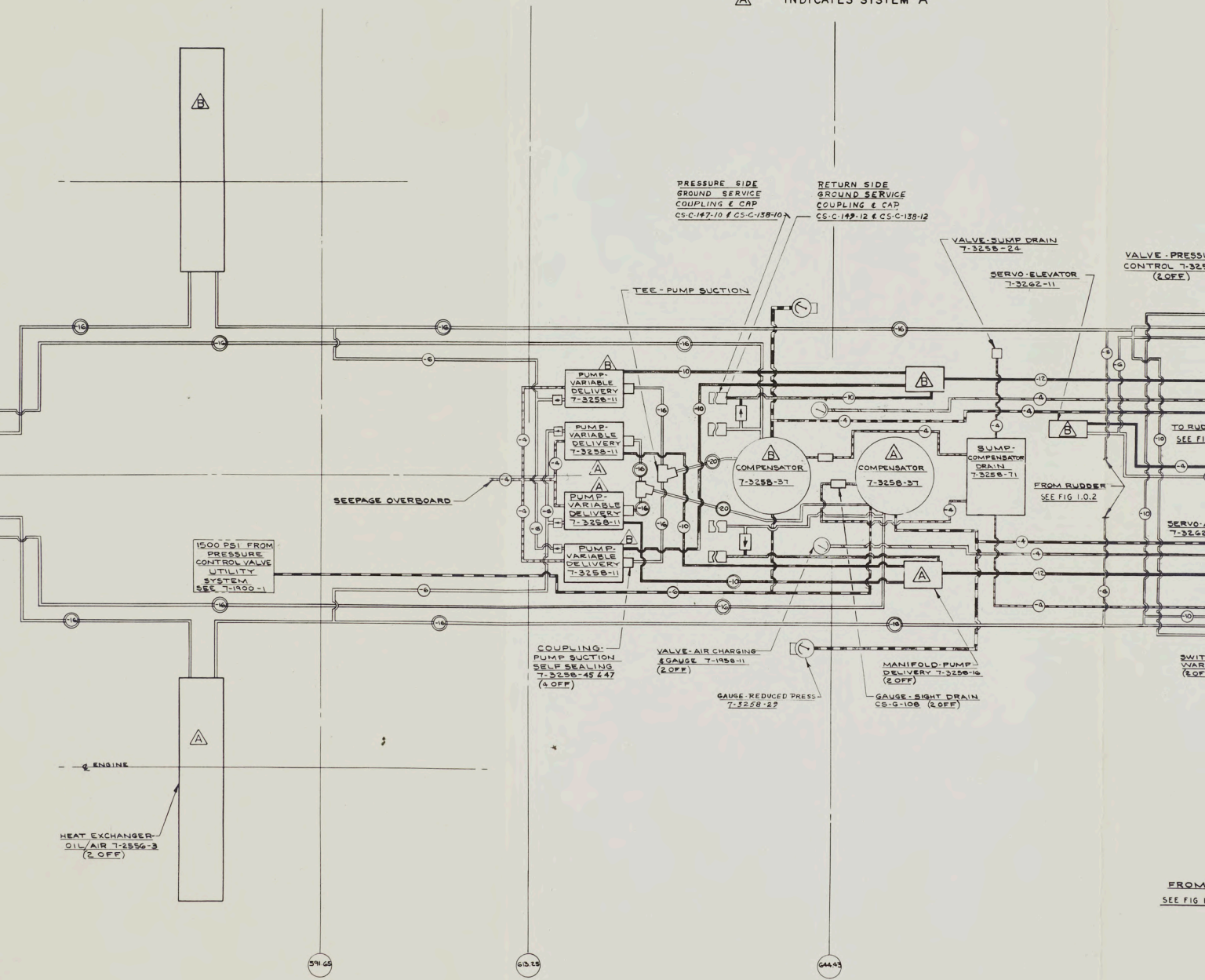

CONFIDENTIAL

**LEGEND**

- SYSTEM PRESSURE (4000 PSI)
- SYSTEM RETURN (90 PSI)
- REDUCED PRESSURE (1500 PSI)
- REDUCED PRESSURE (1250 PSI)
- DRAIN LINE
- HIGH PRESSURE AIR (4000 PSI)
- ⊕ ⊖ INDICATES LINE SIZE IN 1/16 IN.
- △ INDICATES SYSTEM 'A'

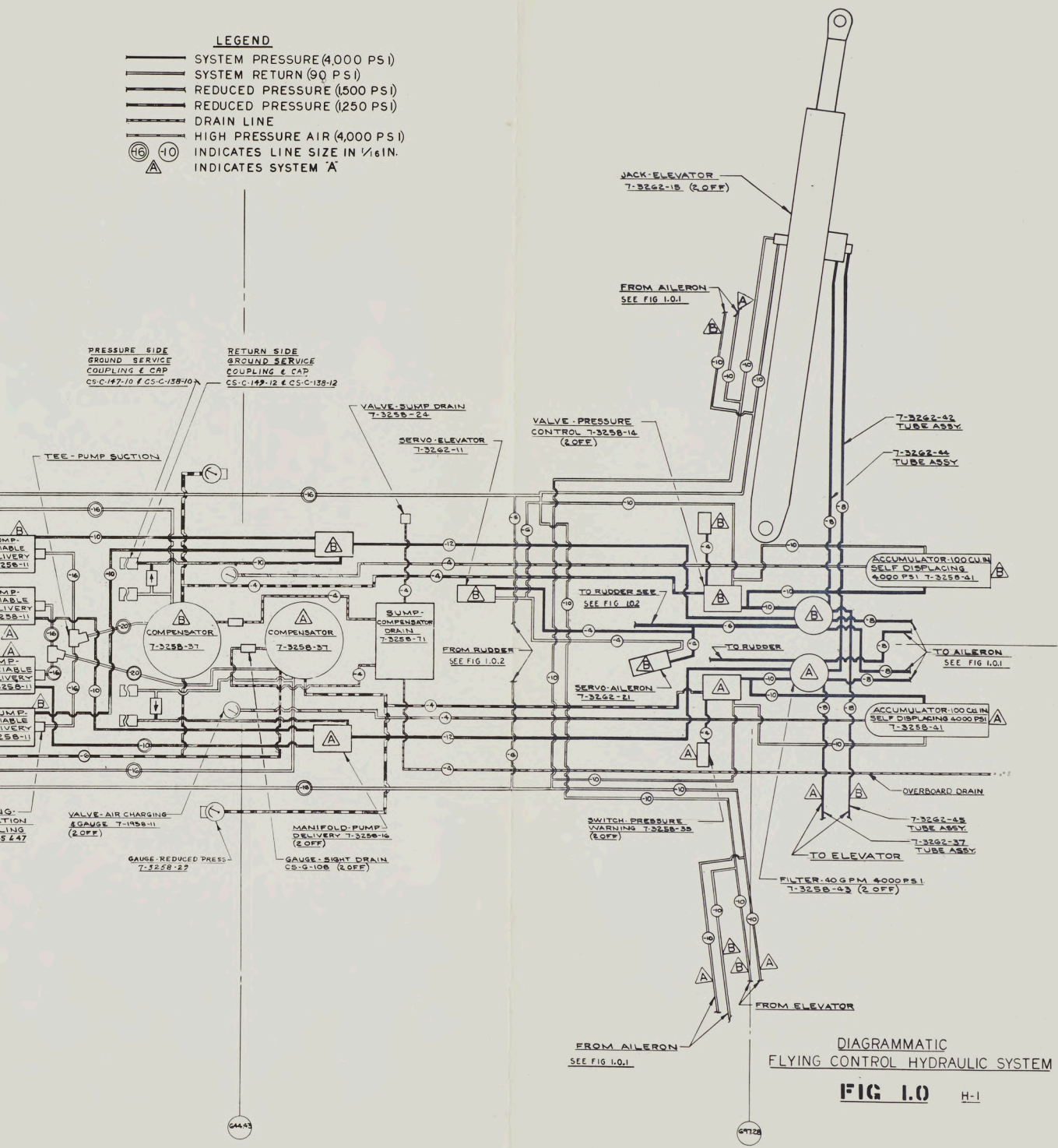

DIAGRAMMATIC  
 FLYING CONTROL HYDRAULIC SYSTEM  
**FIG 1.0** H-1

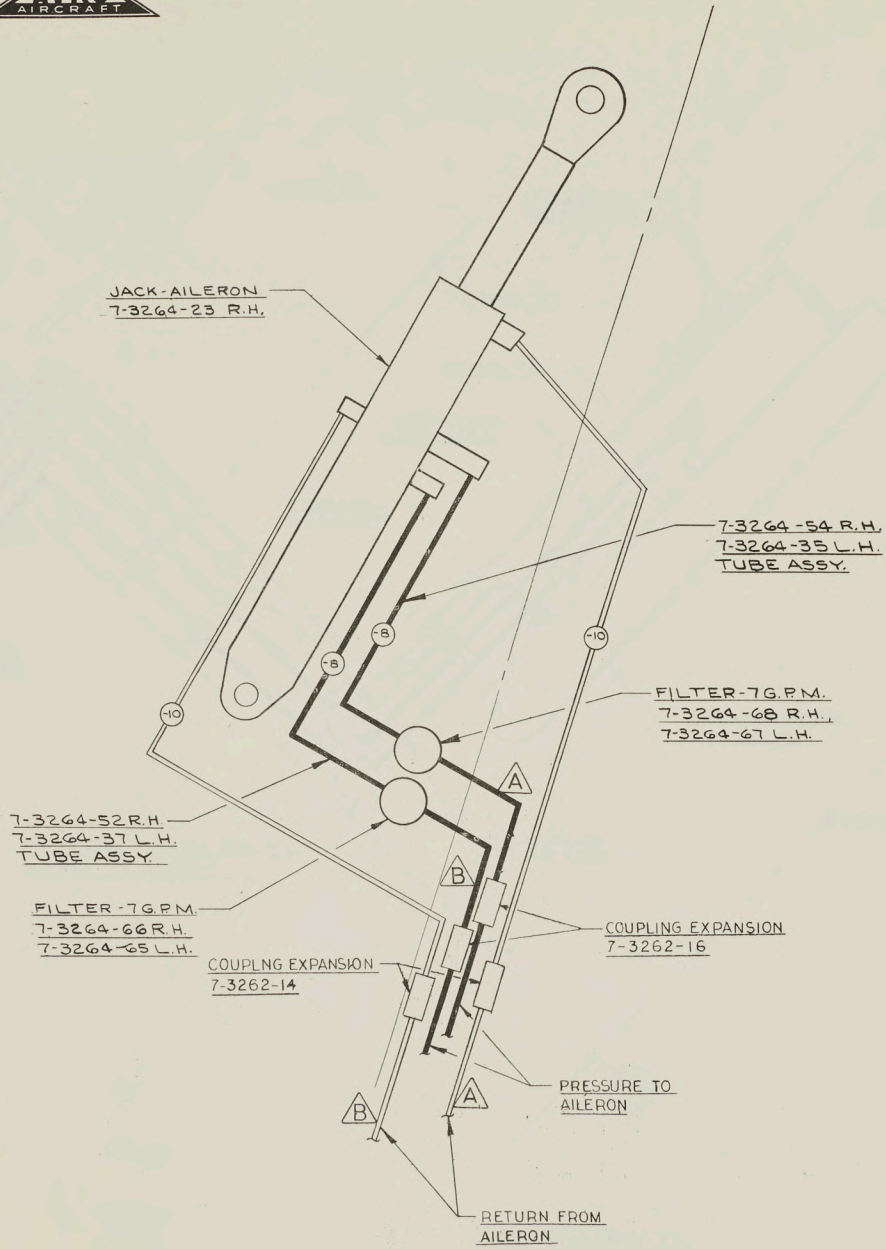

DIAGRAMMATIC  
FLYING CONTROL HYDRAULIC SYSTEM  
(OUTER WING)

FIG 1.0.1 H-1

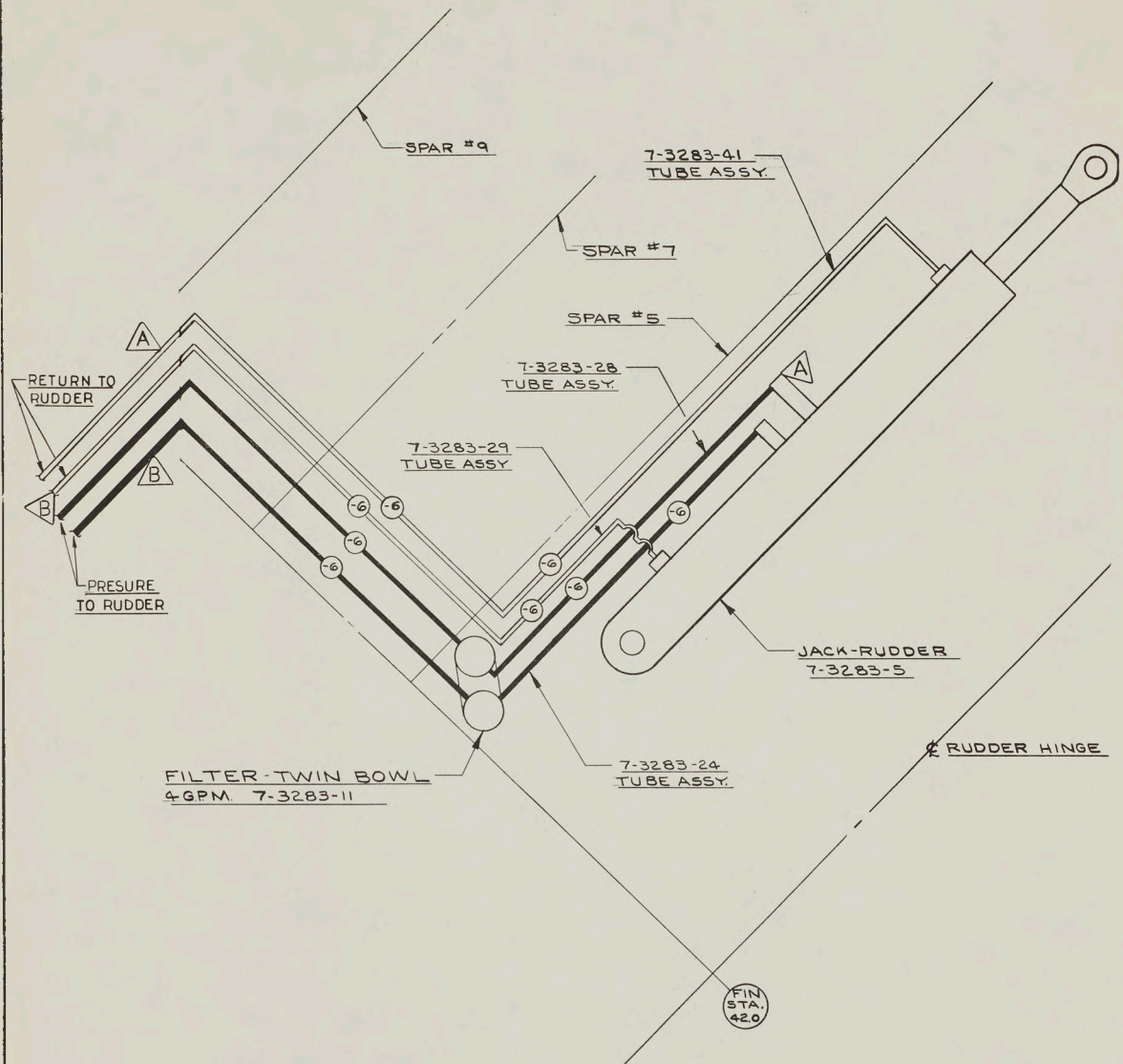

DIAGRAMMATIC  
FLYING CONTROL HYDRAULIC SYSTEM  
(FIN)

FIG 1.0.2 H-1

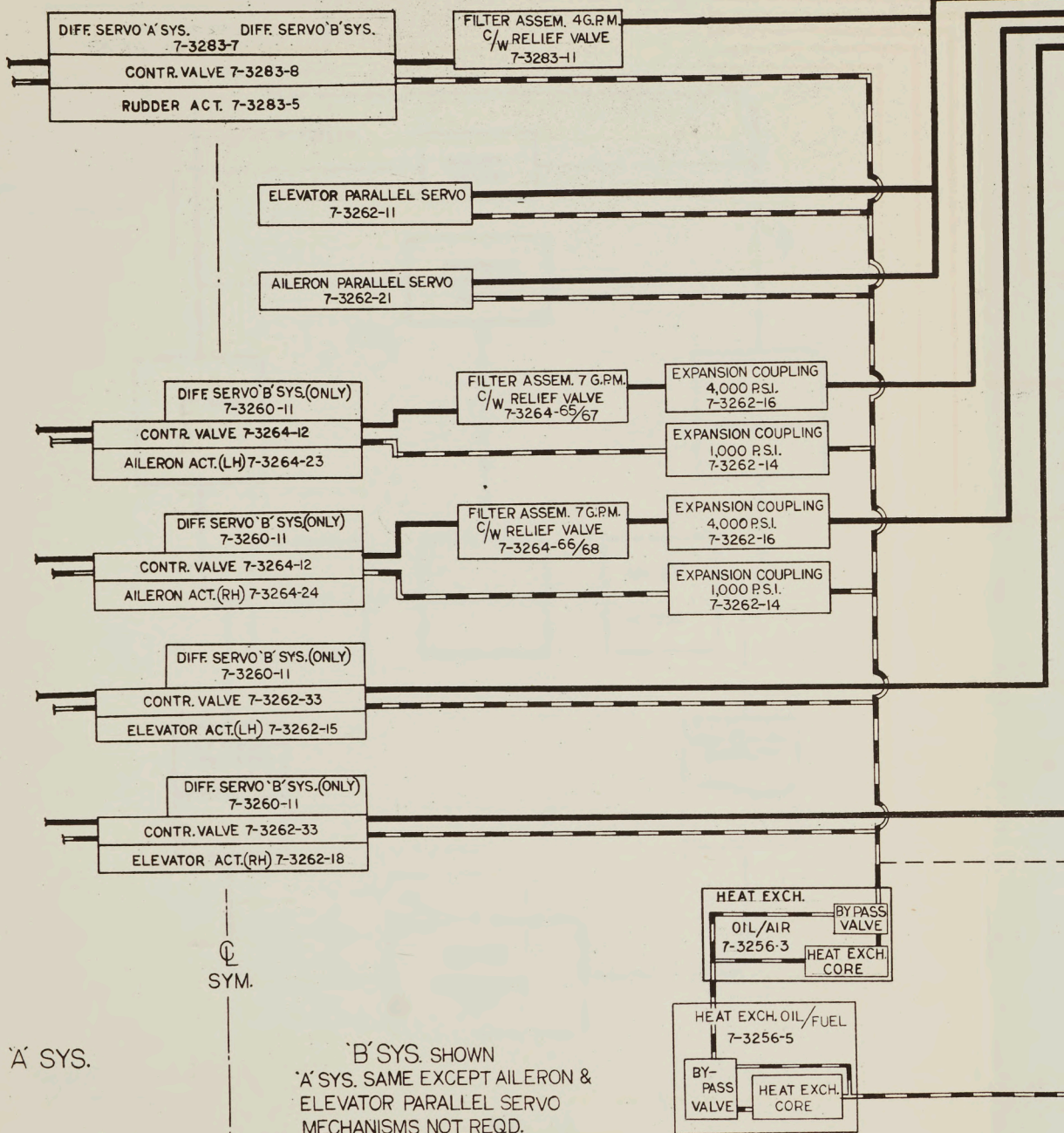

'A' SYS.

SYM.

'B' SYS. SHOWN  
'A' SYS. SAME EXCEPT AILERON &  
ELEVATOR PARALLEL SERVO  
MECHANISMS NOT REQD.

LEGEND:-

- (solid line) — PRESSURE
- - - (dashed line) - - - PRESSURE
- · · (dotted line) · · · RETURN
- · - · (dash-dot line) - · - · RETURN
- X - X (line with 'X') - X - X OVERBD DRAIN

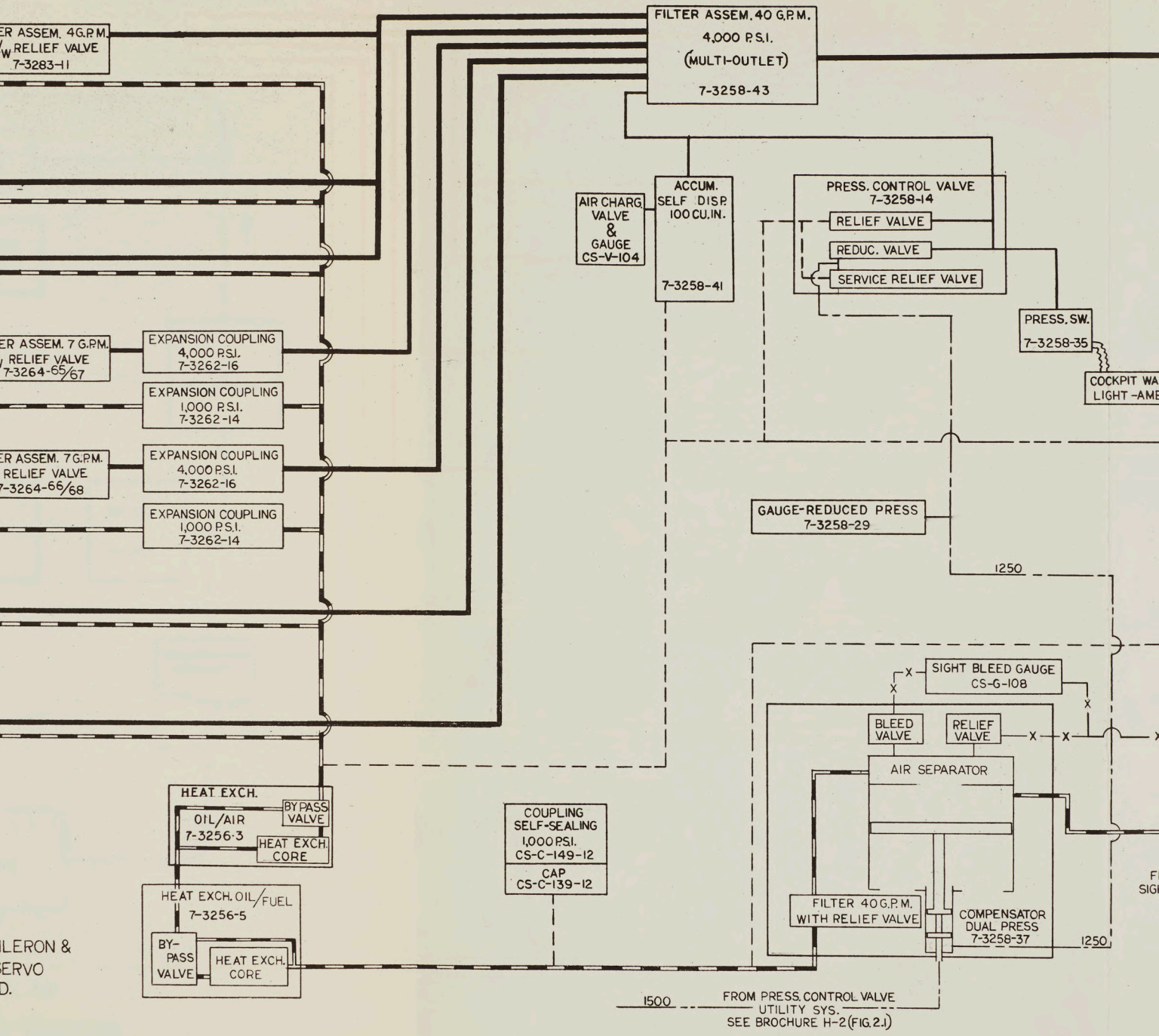

LEGEND:-

- PRESSURE
- - - PRESSURE
- - - RETURN
- - - RETURN
- X - X - OVERBOARD DRAIN

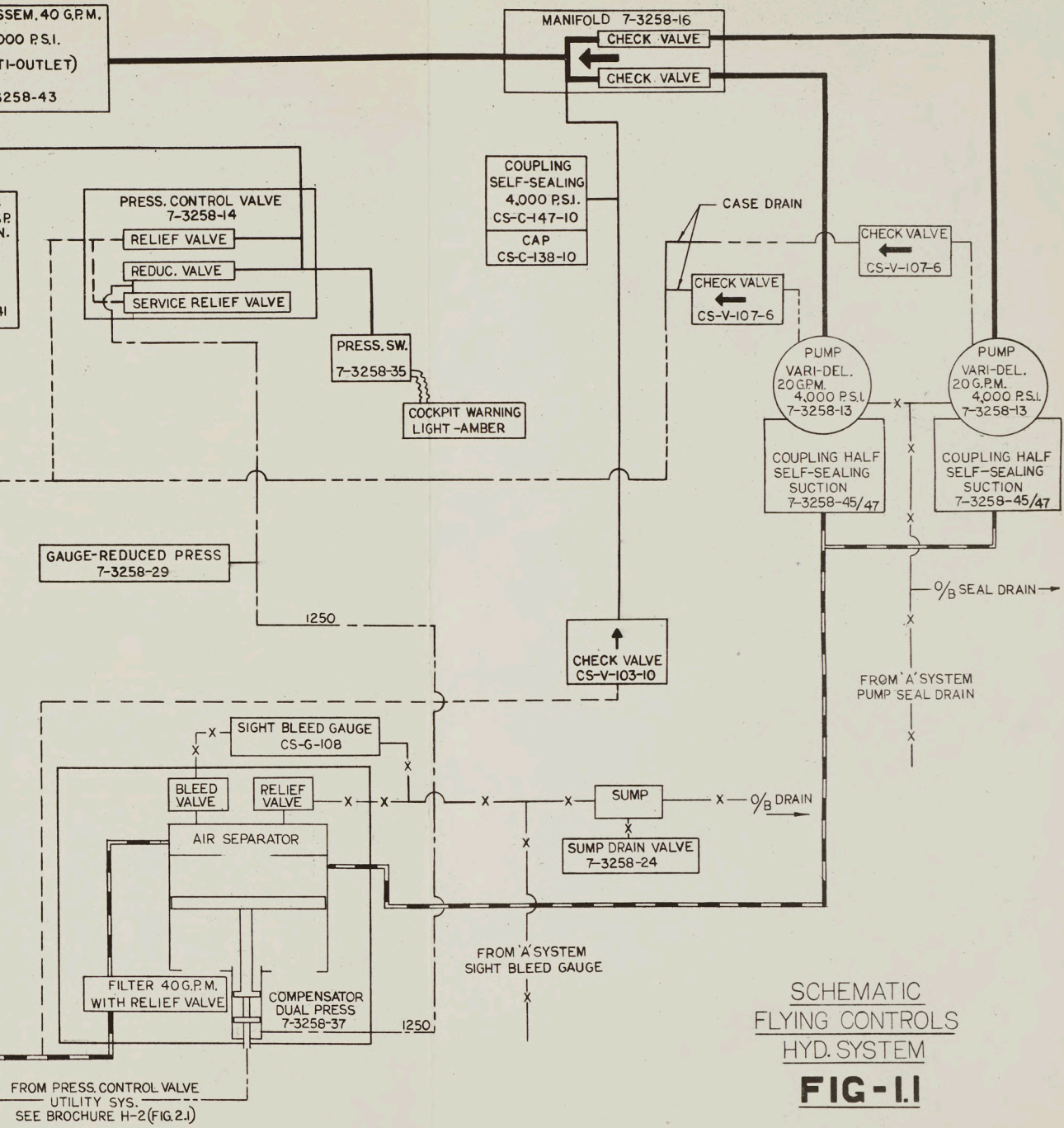

SCHMATIC  
FLYING CONTROLS  
HYD. SYSTEM  
**FIG-11**

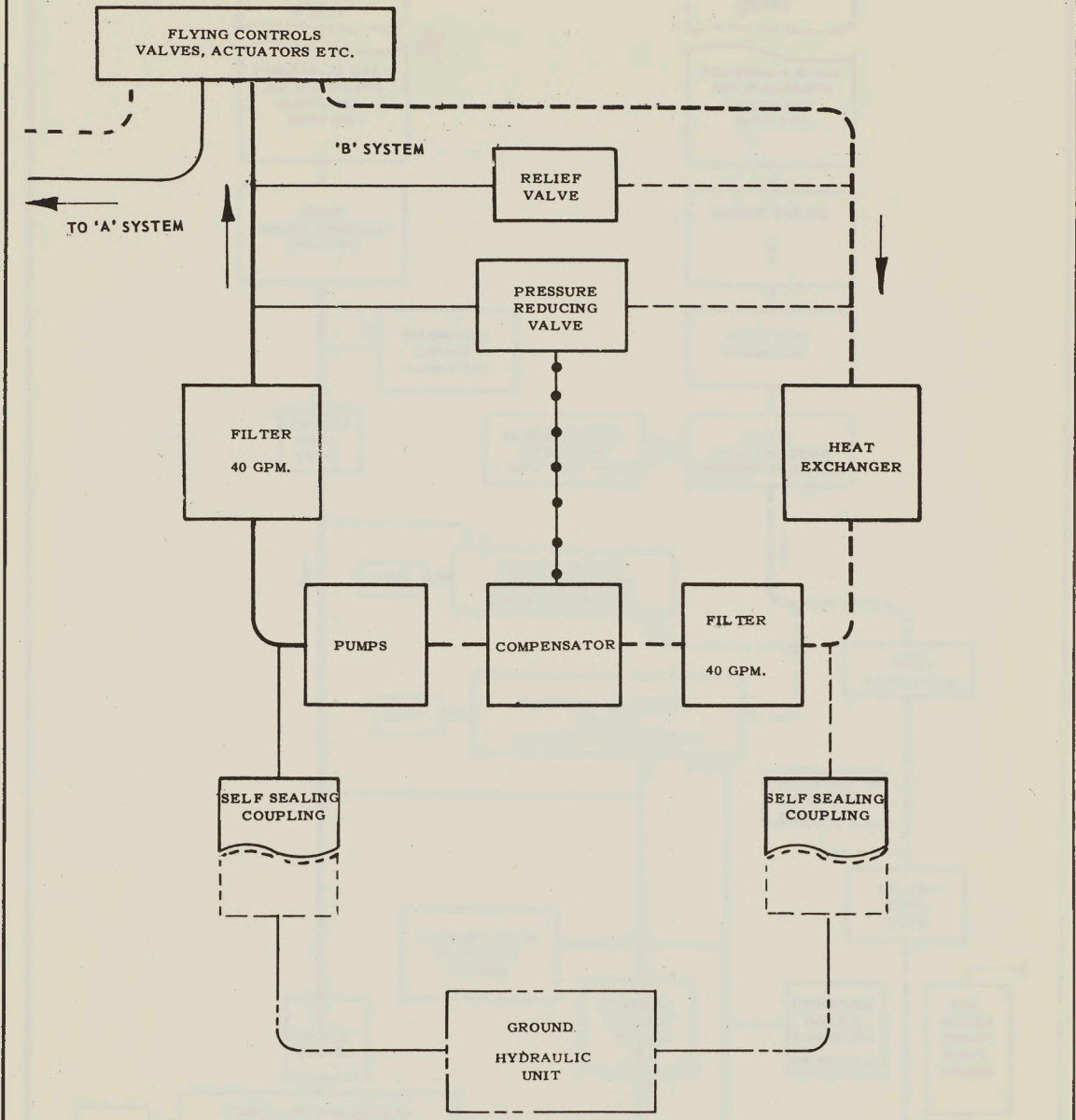

'B' SYSTEM SHOWN  
'A' SYSTEM IDENTICAL

FIG. 1.2  
SIMPLIFIED SCHEMATIC  
FLYING CONTROLS HYDRAULIC SYSTEM

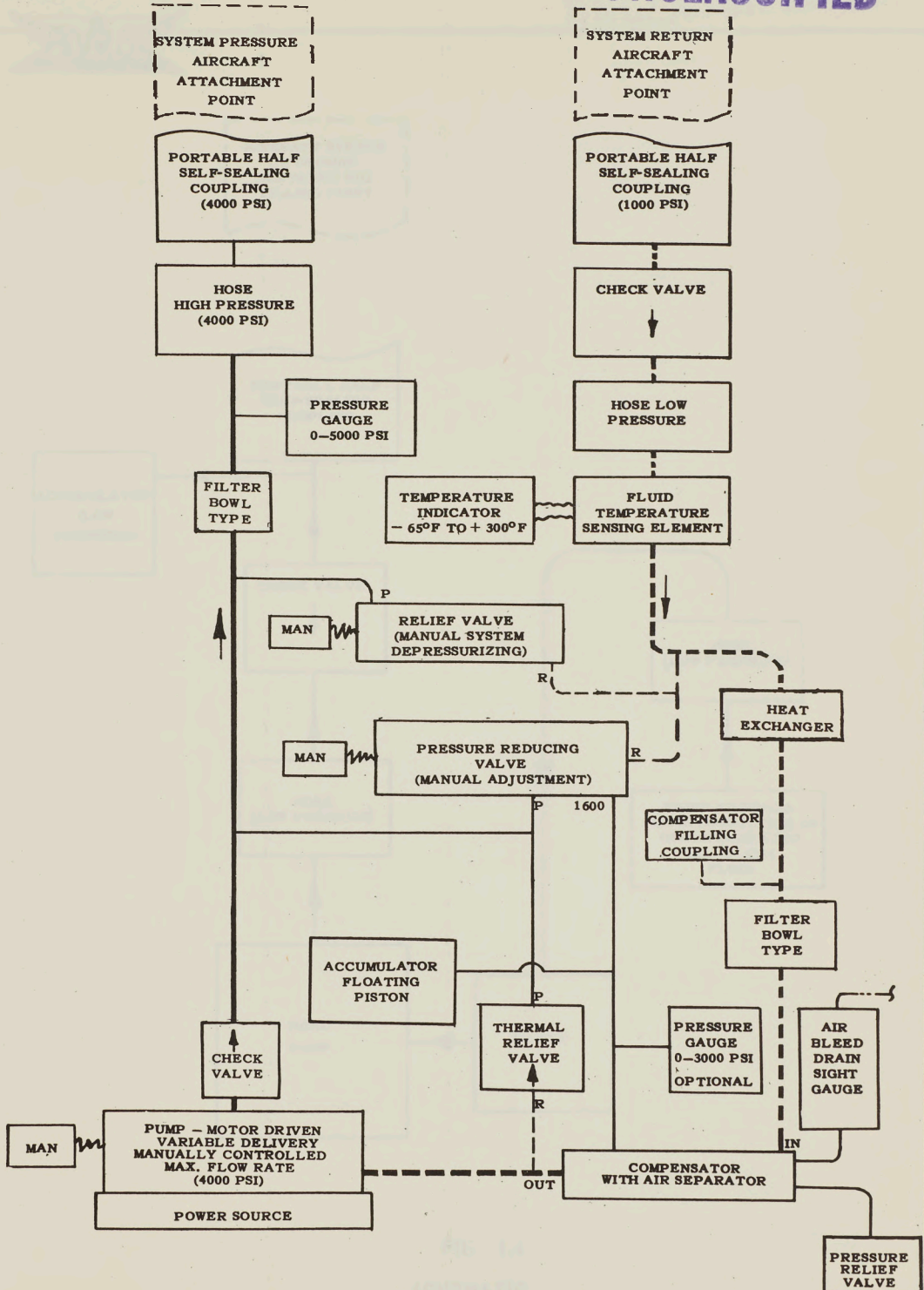

FIG. 1.3  
SCHEMATIC  
HYDRAULIC GROUND SERVICING UNIT

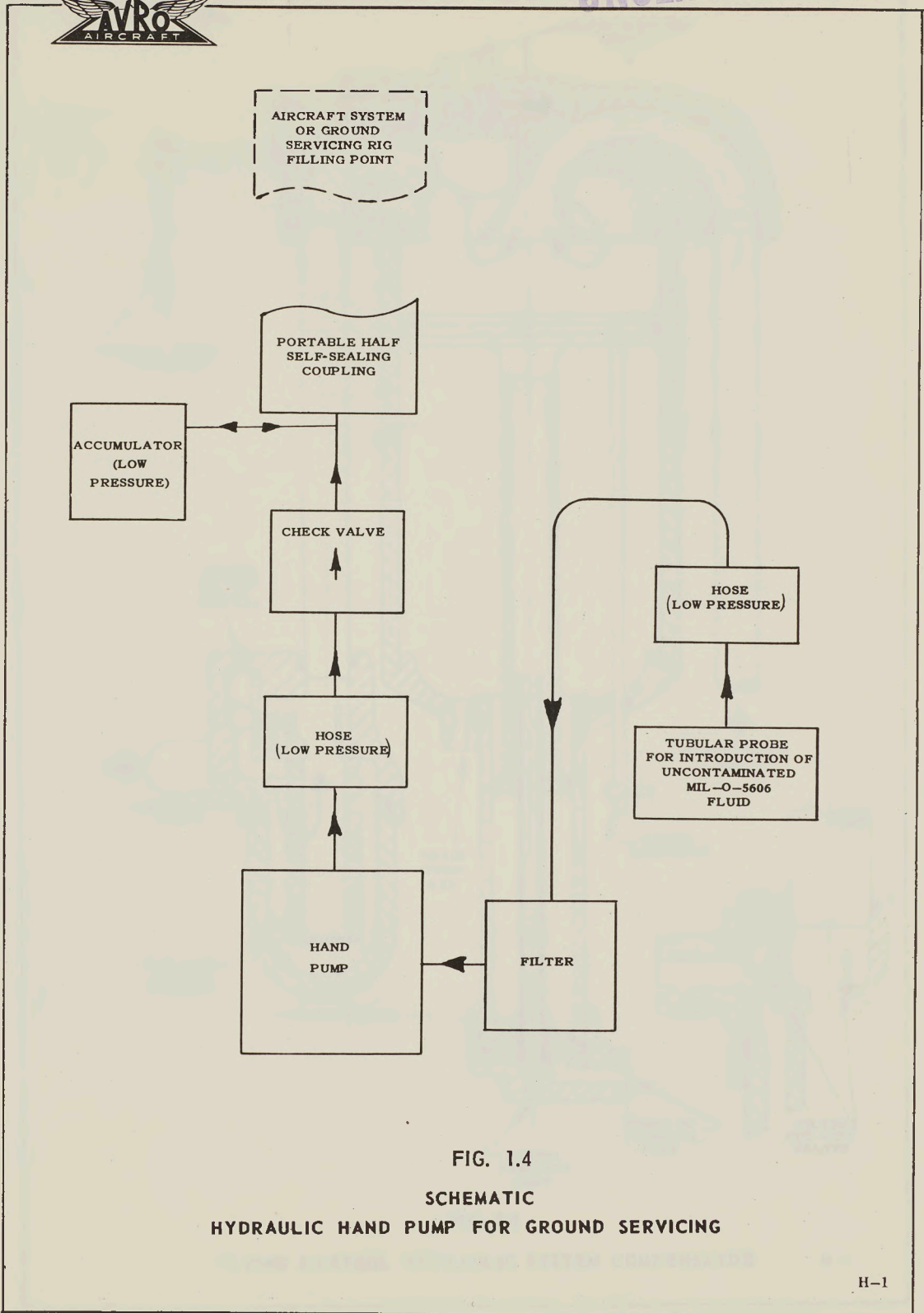

FIG. 1.4  
SCHEMATIC  
HYDRAULIC HAND PUMP FOR GROUND SERVICING

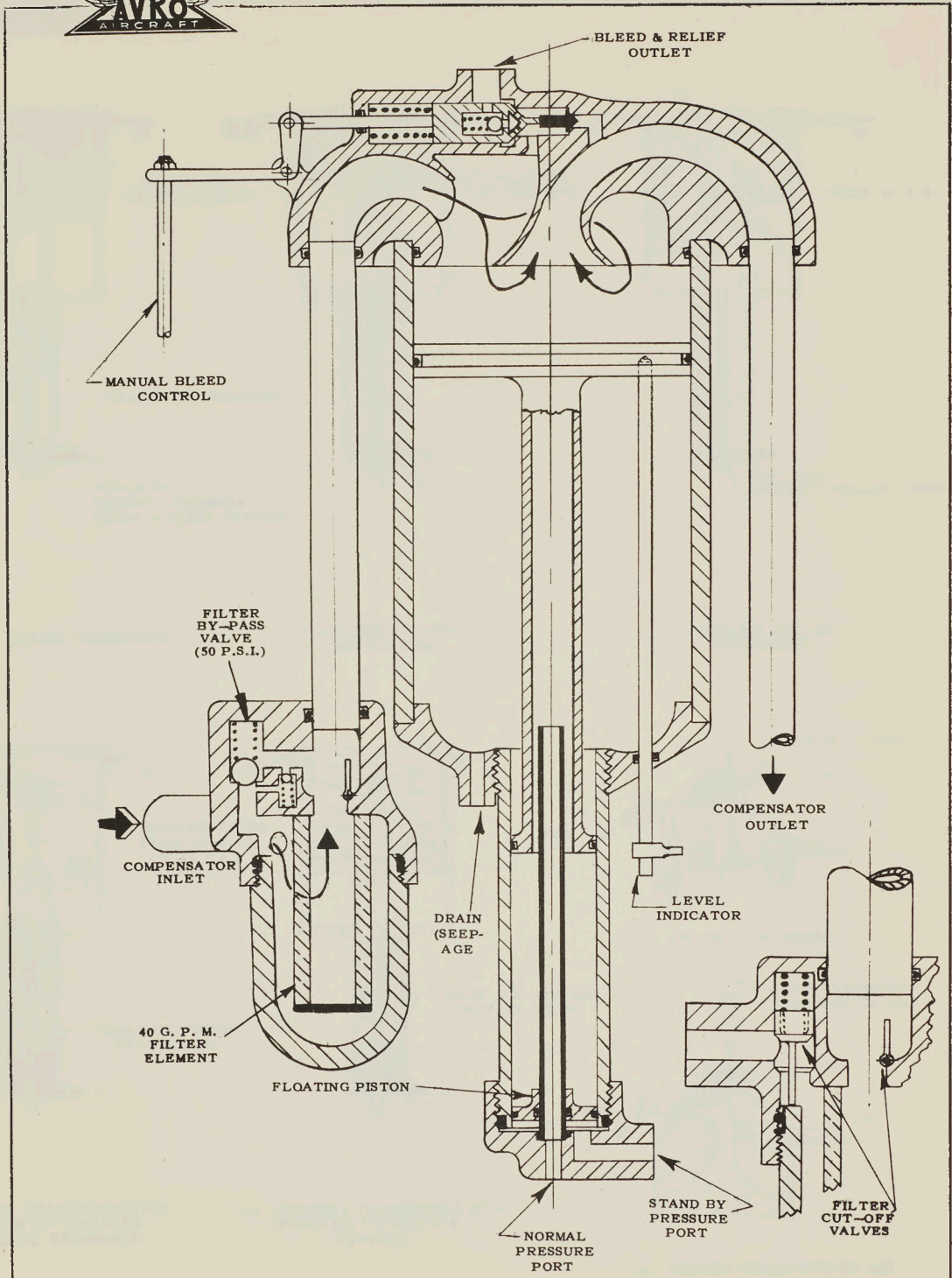
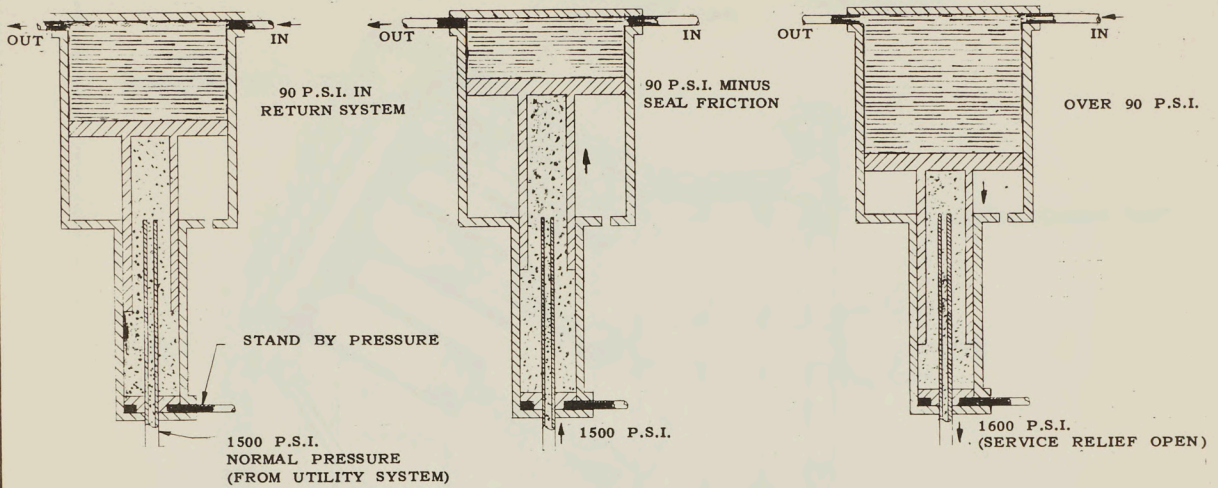

FIG. 2.0

FLYING CONTROL HYDRAULIC SYSTEM COMPENSATOR



UNCLASSIFIED



(a) STATIC CONDITION

(b) SYSTEM VOLUME DECREASING

(c) SYSTEM VOLUME INCREASING

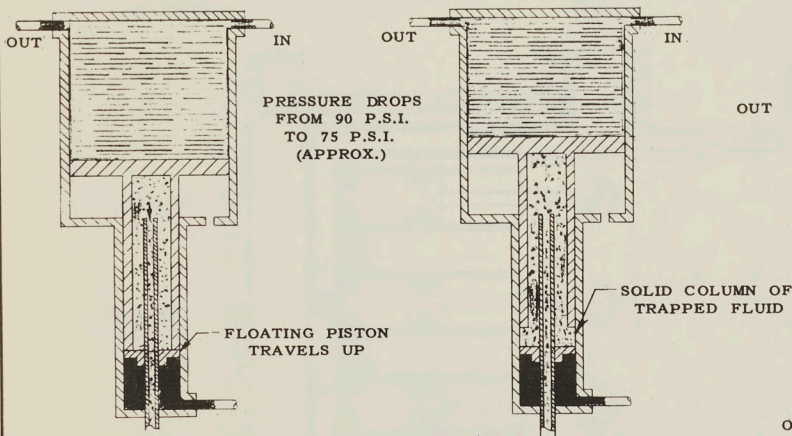

(d) STANDBY PRESSURIZATION (FAILURE OF 1500 P.S.I. NORMAL PRESSURE)

(e) STANDBY PRESSURIZATION (FAILURE OF UTILITY SYSTEM)

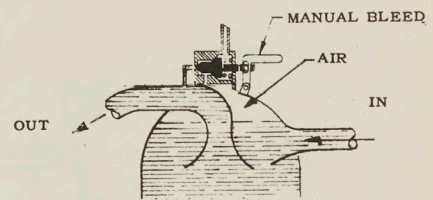

(f) AIR TRAP IN DOME

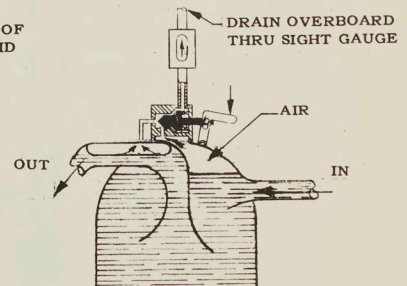

(g) MANUAL BLEEDING OF AIR

FIG. 2.1

FLYING CONTROLS COMPENSATOR FUNCTIONING

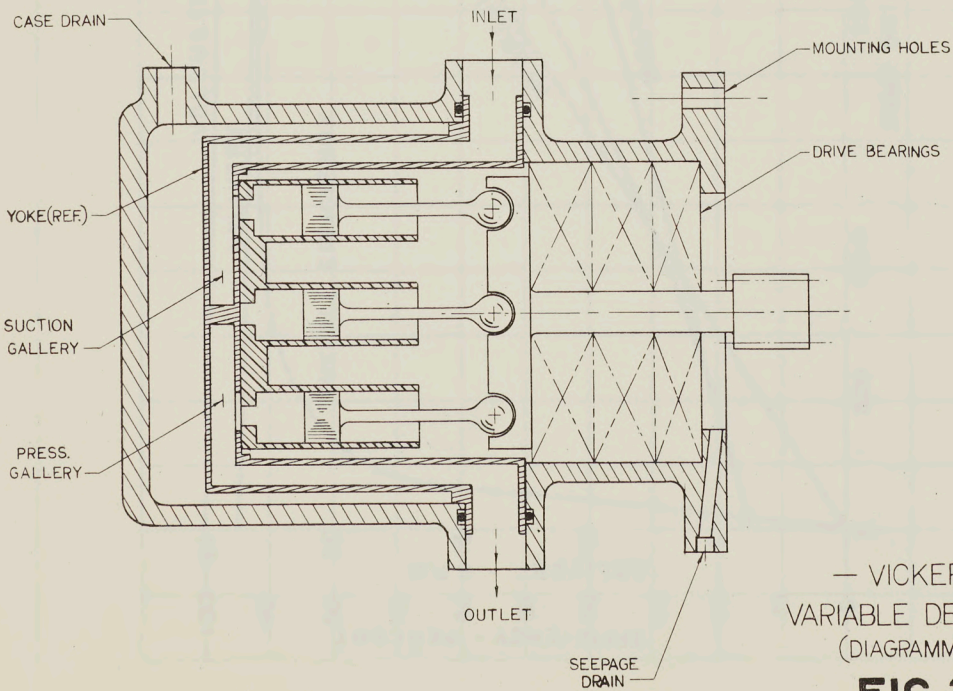
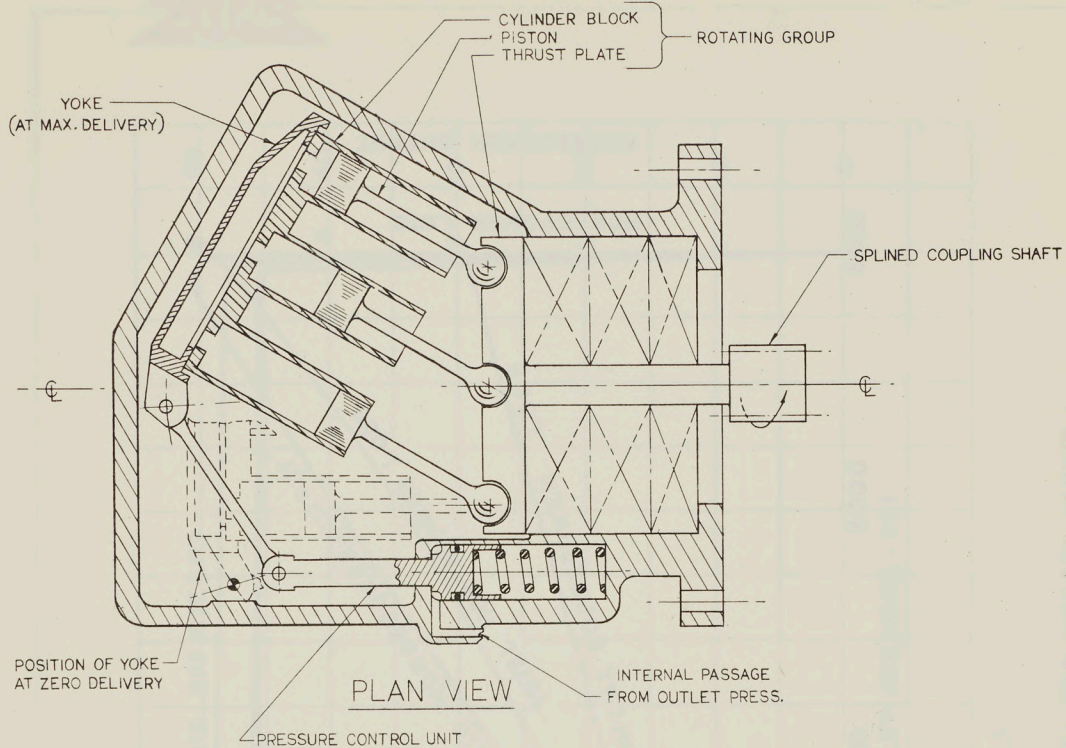

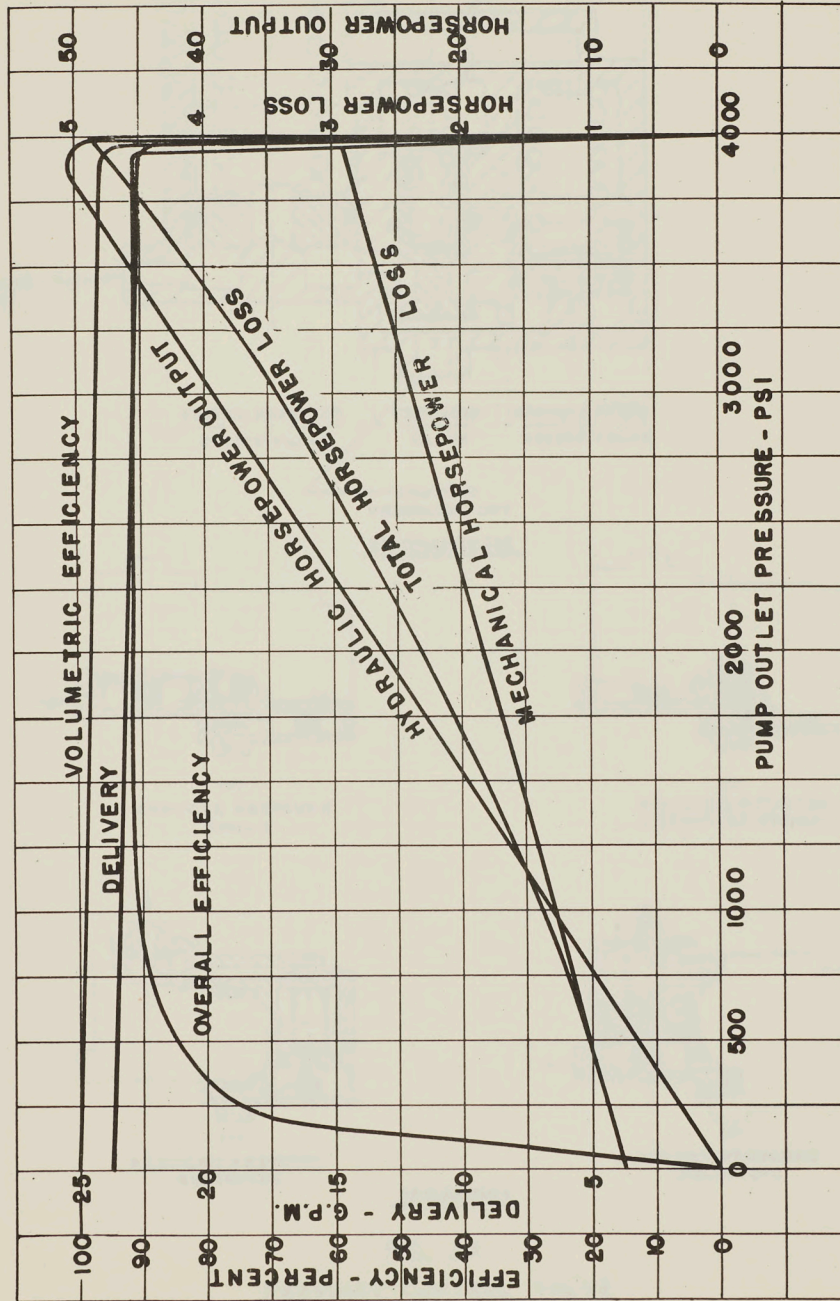
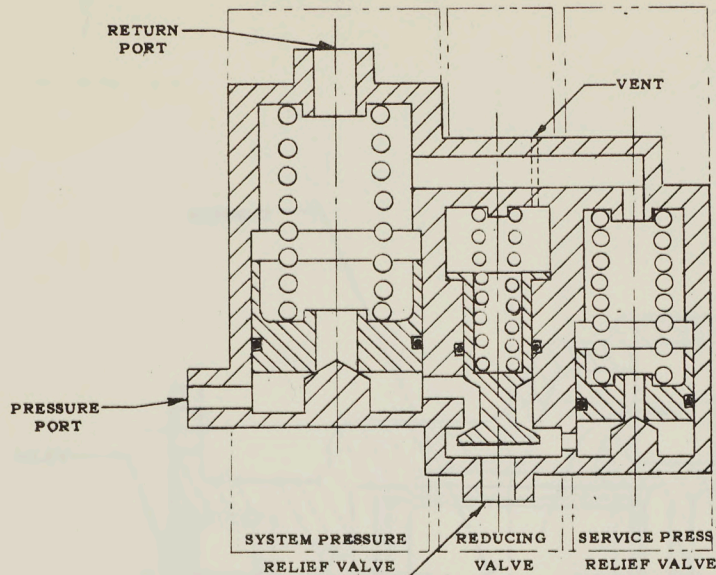

FIG. 2.3

CALCULATED PERFORMANCE CURVES FOR VICKERS AA60659-L VARIABLE DELIVERY PUMP



UNCLASSIFIED



DIAGRAMMATIC

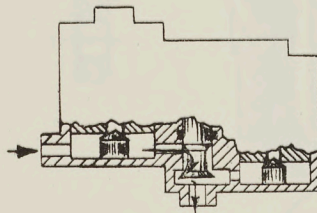

(a)  
REDUCED PRESSURE RISING

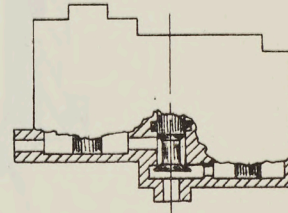

(b)  
SYSTEM & REDUCED PRESSURES NORMAL

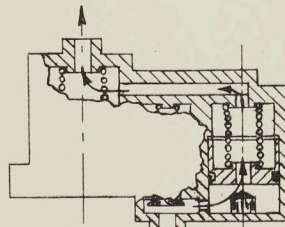

(c)  
REDUCED PRESSURE RELIEVING

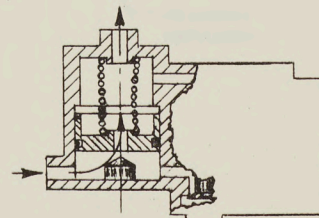

(d)  
SYSTEM PRESSURE RELIEVING

OPERATION

FIG. 2.4  
PRESSURE CONTROL VALVE

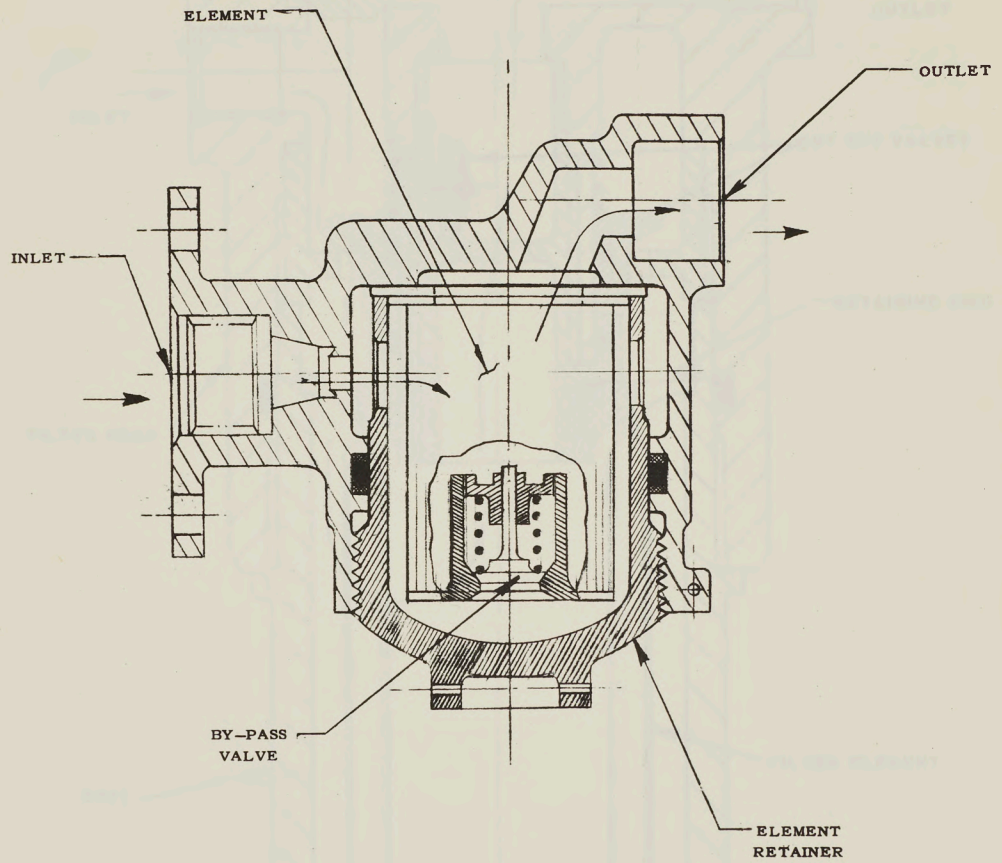

FIG. 2.5  
HYDRAULIC FILTER 7 GPM

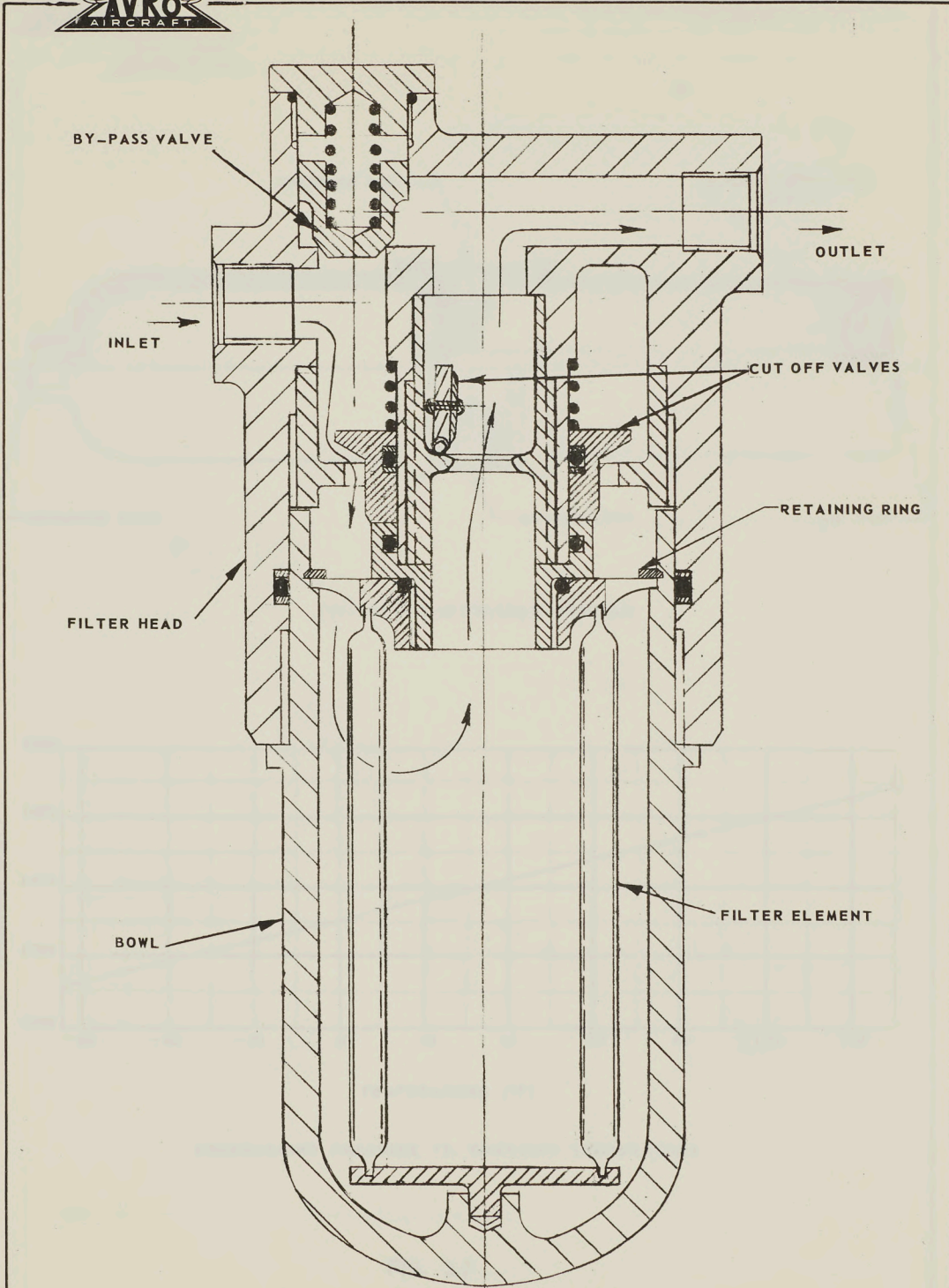
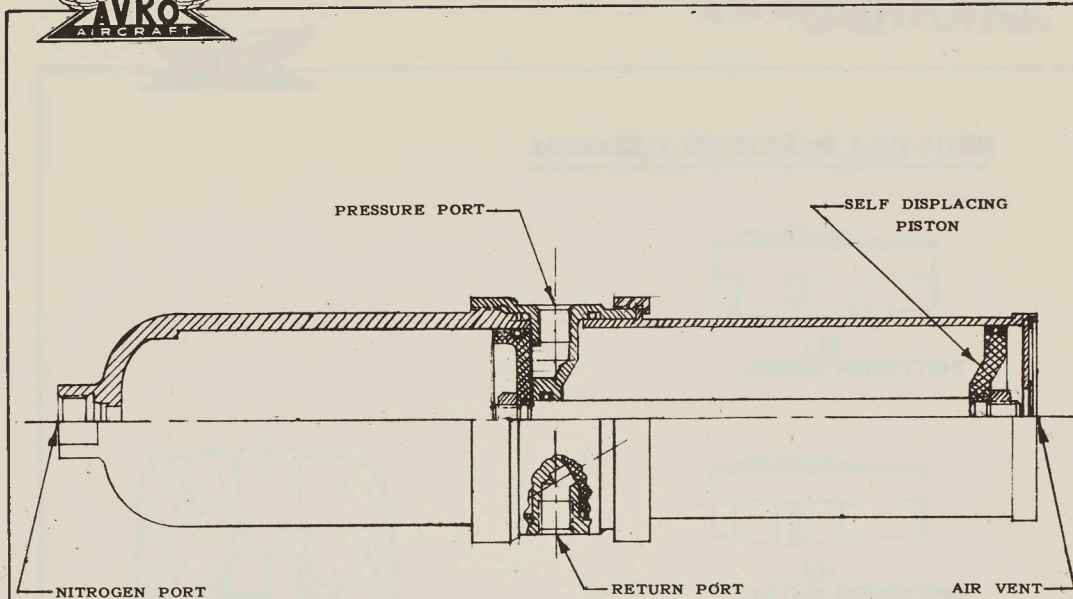

FIG. 2.6

HYDRAULIC FILTER 40 GPM.

H-1

H-2



PISTON IN PRECHARGED POSITION

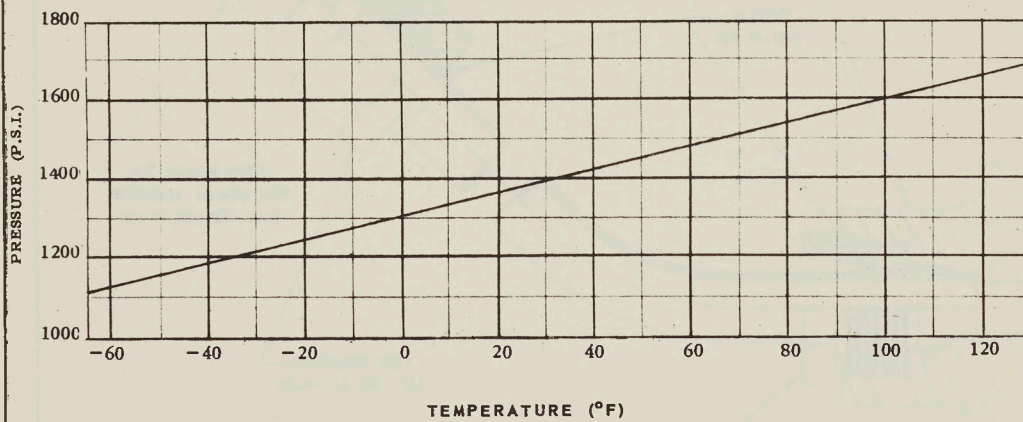

PRECHARGING PRESSURE VS. CHARGING TEMPERATURE

FIG. 2.7

SELF-DISPLACING ACCUMULATOR



ASSEMBLY OF SLEEVE AND TUBE

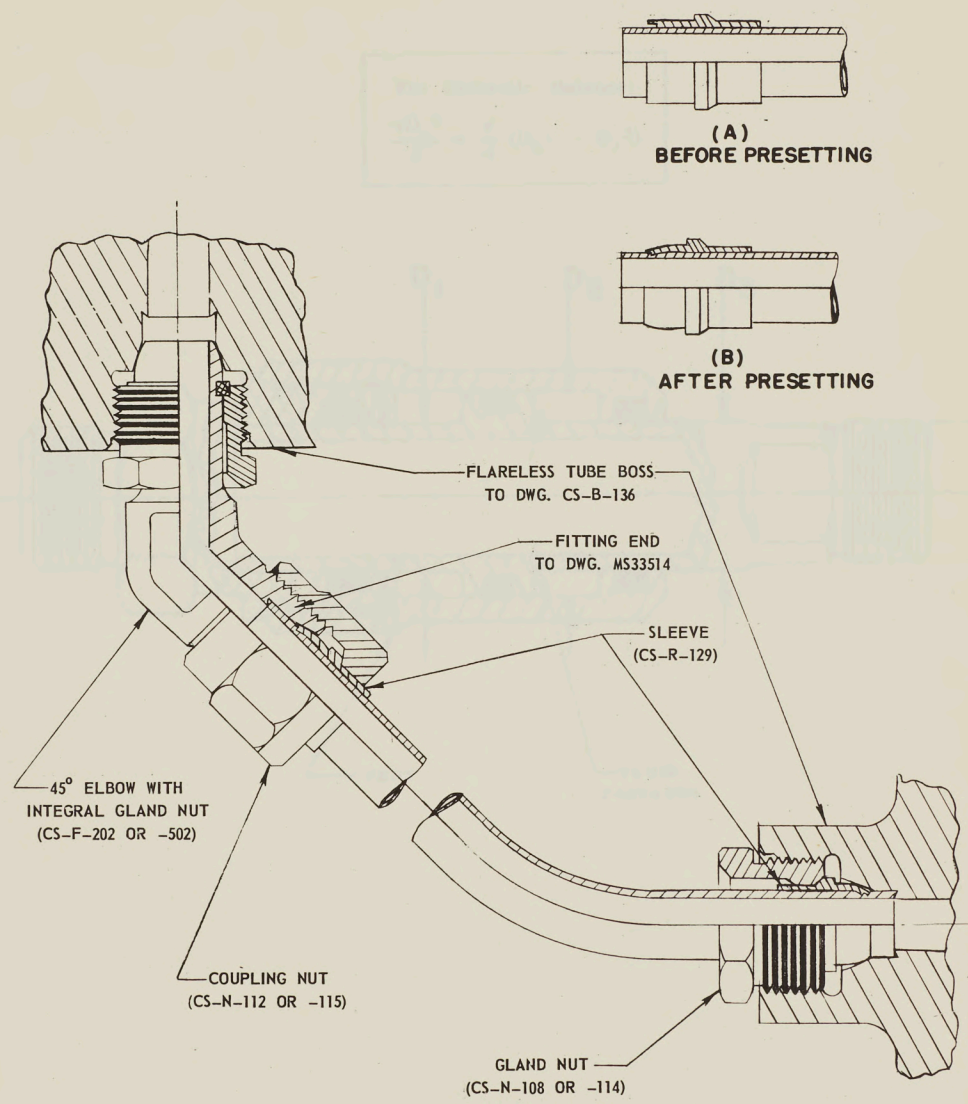

NOTE: CS NUMBERS REFER TO AVRO STANDARD DRAWINGS.

**FIG. 2.8.**  
**FLARELESS TUBE CONNECTIONS.**

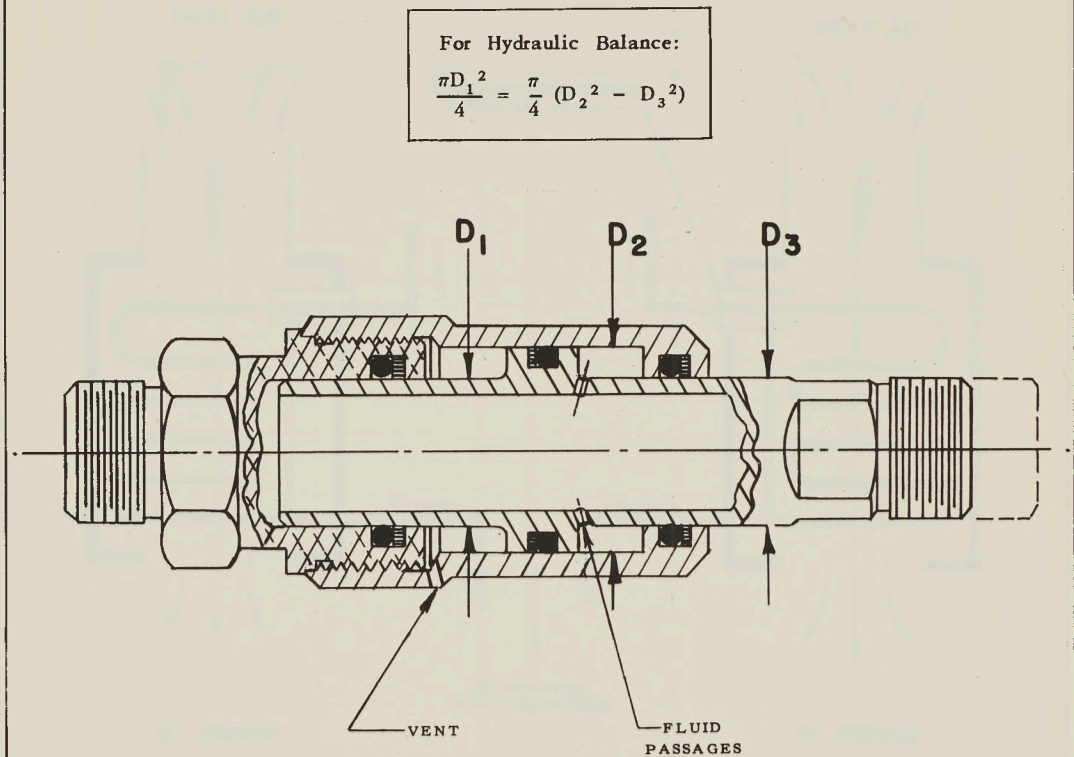

FIG. 2.9  
EXPANSION COUPLING  
(BALANCED TYPE)



UNCLASSIFIED

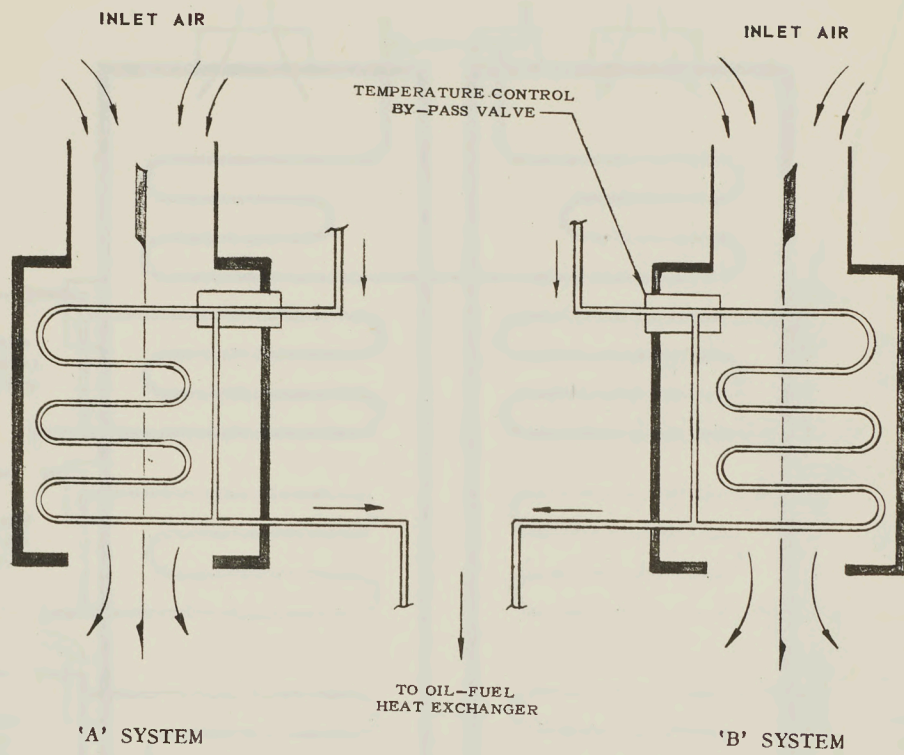

FIG. 2.10

HEAT EXCHANGER  
OIL TO AIR



UNCL/CONFIDENTIAL

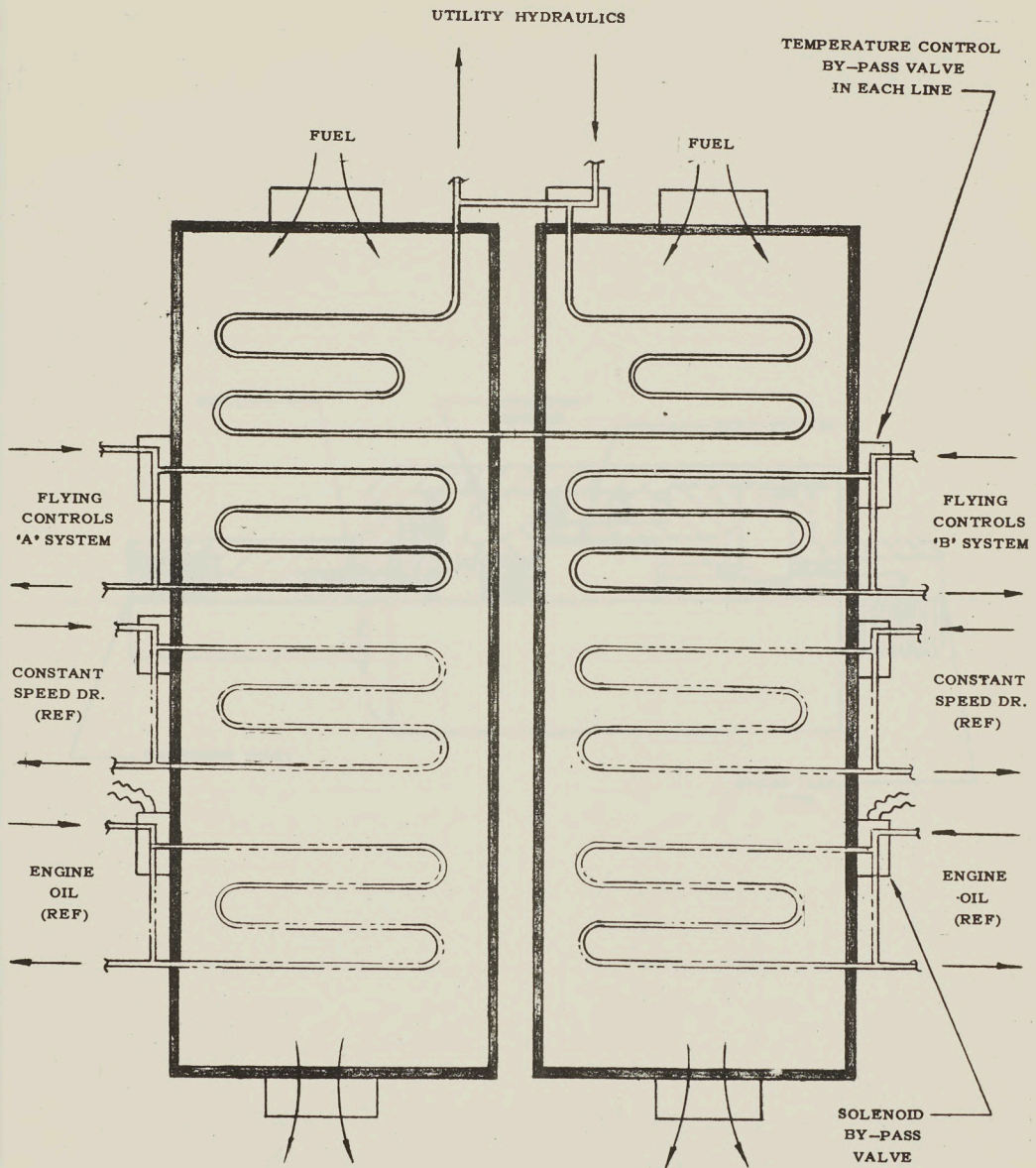

FIG. 2.11

HEAT EXCHANGER  
OIL TO FUEL

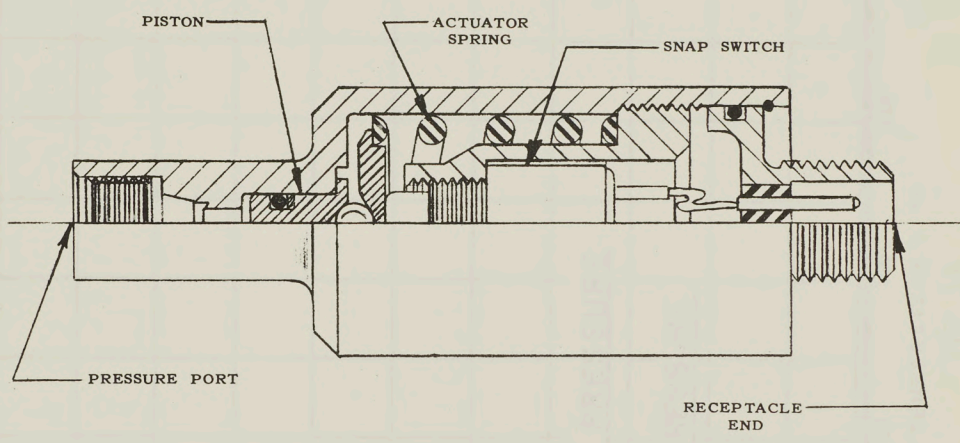

FIG. 2.12  
HYDRAULIC PRESSURE SWITCH

H-1  
H-2

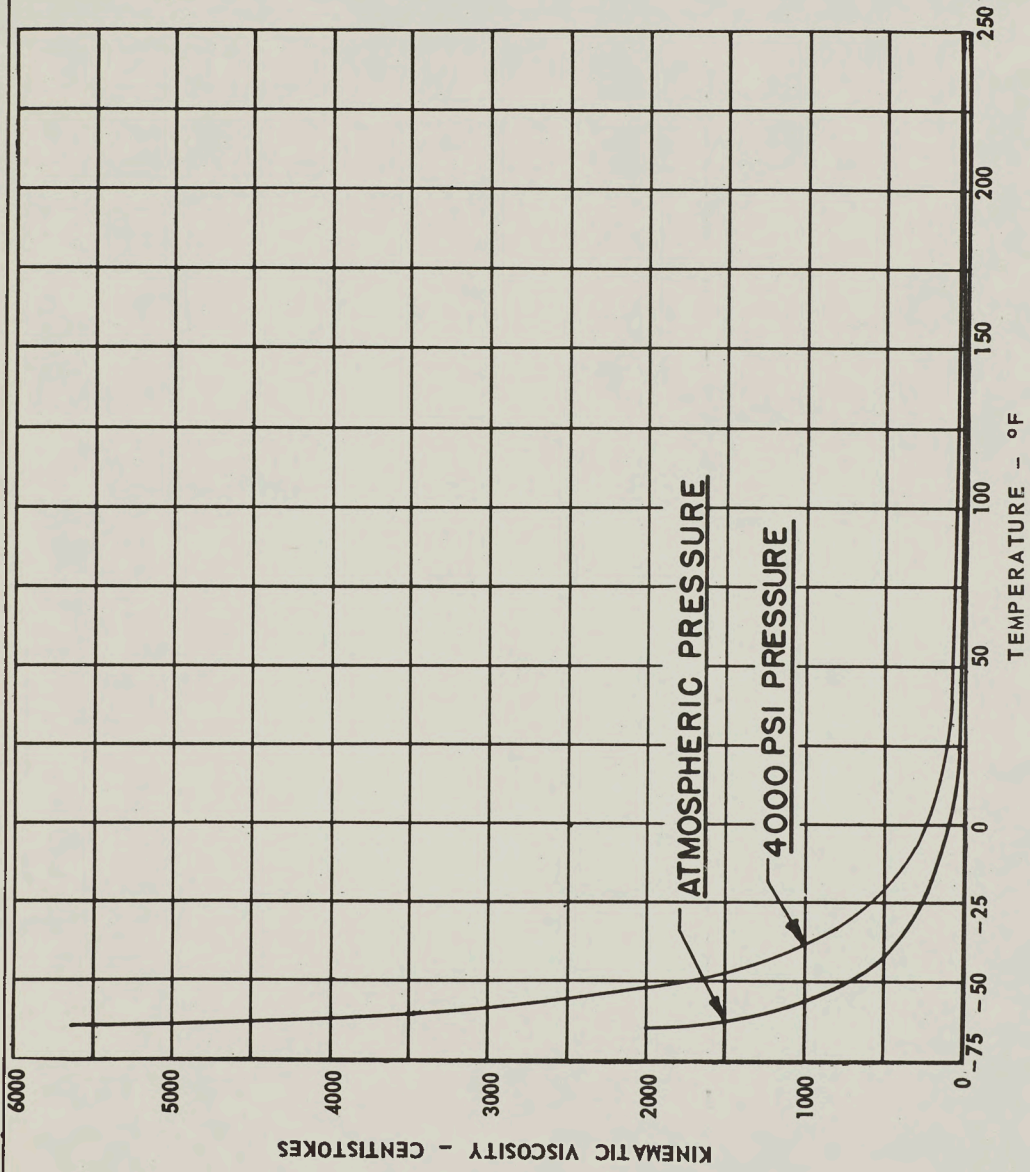

FIG. 3.0

KINEMATIC VISCOSITY VS TEMPERATURE

